



Chipsmall Limited consists of a professional team with an average of over 10 year of expertise in the distribution of electronic components. Based in Hongkong, we have already established firm and mutual-benefit business relationships with customers from,Europe,America and south Asia,supplying obsolete and hard-to-find components to meet their specific needs.

With the principle of “Quality Parts,Customers Priority,Honest Operation,and Considerate Service”,our business mainly focus on the distribution of electronic components. Line cards we deal with include Microchip,ALPS,ROHM,Xilinx,Pulse,ON,Everlight and Freescale. Main products comprise IC,Modules,Potentiometer,IC Socket,Relay,Connector.Our parts cover such applications as commercial,industrial, and automotives areas.

We are looking forward to setting up business relationship with you and hope to provide you with the best service and solution. Let us make a better world for our industry!



Contact us

Tel: +86-755-8981 8866 Fax: +86-755-8427 6832

Email & Skype: info@chipsmall.com Web: www.chipsmall.com

Address: A1208, Overseas Decoration Building, #122 Zhenhua RD., Futian, Shenzhen, China





DFRobot Digital Vibration Sensor V2 SKU:DFR0027



Contents

- [1 Introduction](#)
- [2 Specification](#)
- [3 Tutorial](#)
 - [3.1 Connection Diagram](#)
 - [3.2 Sample Code](#)
 - [3.3 Result](#)
- [4 Trouble shooting](#)

Introduction

What's the simplest way to check vibration with Arduino? Use a vibration sensor from DFRobot. You can directly plug it on our IO Expansion Shield V7. Just vibrate this sensor, Arduino can receive a digital signal. It's easy to account and program in Arduino.

Despite it's simple, you can make full use of it with creative thinking, like step counting, Crash warning light and so on.

Specification

- Wide voltage range from 3.3V to 5V
- Standard assembling structure (two 3mm diameter holes with multiple of 5mm as distance from center)
- Easily recognitive interfaces of sensors ("A" for analog and "D" for digital)
- Icons to simply illustrate sensor function
- High quality connector
- Immersion gold surface
- IO Type: Digital
- Switch life: up to 10 million seconds
- Open circuit resistance: 10Mohm
- Supply Voltage: 3.3V to 5V
- Interface: Digital
- Size:22x30mm

Tutorial

Connection Diagram

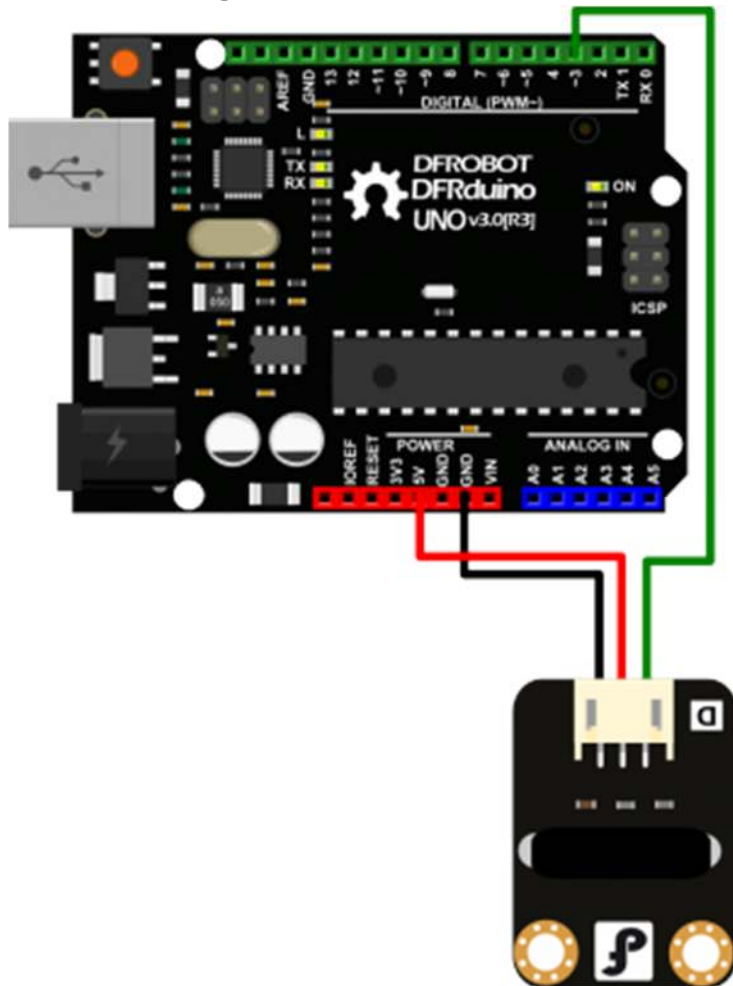

Sample Code

```
#define SensorLED 13
//Connect the sensor to digital Pin 3 which is Interrupts 1.
#define SensorINPUT 3

unsigned char state = 0;

void setup() {
    pinMode(SensorLED, OUTPUT);
    pinMode(SensorINPUT, INPUT);
    //Trigger the blink function when the falling edge is detected
    attachInterrupt(1, blink, FALLING);
}

void loop() {
    if (state != 0) {
        state = 0;
        digitalWrite(SensorLED, HIGH);
        delay(500);
    }
    else
        digitalWrite(SensorLED, LOW);
}

//Interrupts function
void blink() {
    state++;
}

{
```

```
1 #define SensorLED 13
```

```
2 //Connect the sensor to digital Pin 3 which is Interrupts 1.
3 #define SensorINPUT 3
4
5 unsigned char state = 0;
6
7 void setup() {
8   pinMode(SensorLED, OUTPUT);
9   pinMode(SensorINPUT, INPUT);
10  //Trigger the blink function when the falling edge is detected
11  attachInterrupt(1, blink, FALLING);
12 }
13
14 void loop() {
15   if (state != 0) {
16     state = 0;
17     digitalWrite(SensorLED, HIGH);
18     delay(500);
19   }
20   else
21     digitalWrite(SensorLED, LOW);
22 }
23
24 //Interrupts function
25 void blink() {
26   state++;
27 }
```

Result

As shown in figure connection , plug LED and lay a finger on Digital Vibration Sensor , LED will be lightened

Trouble shooting

More question and cool idea, visit [DFRobot Forum](#)