



Chipsmall Limited consists of a professional team with an average of over 10 year of expertise in the distribution of electronic components. Based in Hongkong, we have already established firm and mutual-benefit business relationships with customers from,Europe,America and south Asia,supplying obsolete and hard-to-find components to meet their specific needs.

With the principle of "Quality Parts,Customers Priority,Honest Operation,and Considerate Service",our business mainly focus on the distribution of electronic components. Line cards we deal with include Microchip,ALPS,ROHM,Xilinx,Pulse,ON,Everlight and Freescale. Main products comprise IC,Modules,Potentiometer,IC Socket,Relay,Connector.Our parts cover such applications as commercial,industrial, and automotives areas.

We are looking forward to setting up business relationship with you and hope to provide you with the best service and solution. Let us make a better world for our industry!



## Contact us

Tel: +86-755-8981 8866 Fax: +86-755-8427 6832

Email & Skype: info@chipsmall.com Web: www.chipsmall.com

Address: A1208, Overseas Decoration Building, #122 Zhenhua RD., Futian, Shenzhen, China





## Flyduino-A 12 Servo Controller(SKU:DFR0136)

---



### Contents

- [1 Introduction](#)
  - [1.1 Specification](#)
- [2 Pin Diagram](#)
- [3 Sample Code](#)

### Introduction

This is probably the smallest Arduino controller specifically designed for controlling servos. It features a 12 standard servo control capability with an Xbee socket which can be used in model helicopters or UAVs via the Xbee link. The feather weight (7.5g) makes it an ideal controller for application with a limited payload. The built in regulator allows the input voltage to vary from 3.5-8V which fits most power supplies without any modification.

Note: A FTDI Basic breakout is required to upload the program (@3.3V)

Warning: The controller is working under 3.3V, please do not program it with a 5V FTDI breakout, it will damage the module permanently.

## Specification

- CPU:Atmega328P
- Working voltage:3.3V
- Input voltage:3.5-8V (regulated)
- 12 Channel servo control
- Xbee socket
- Analog input: 8
- SRAM:2K
- EEPROM:1K
- Weight:7.5 gram

## Pin Diagram

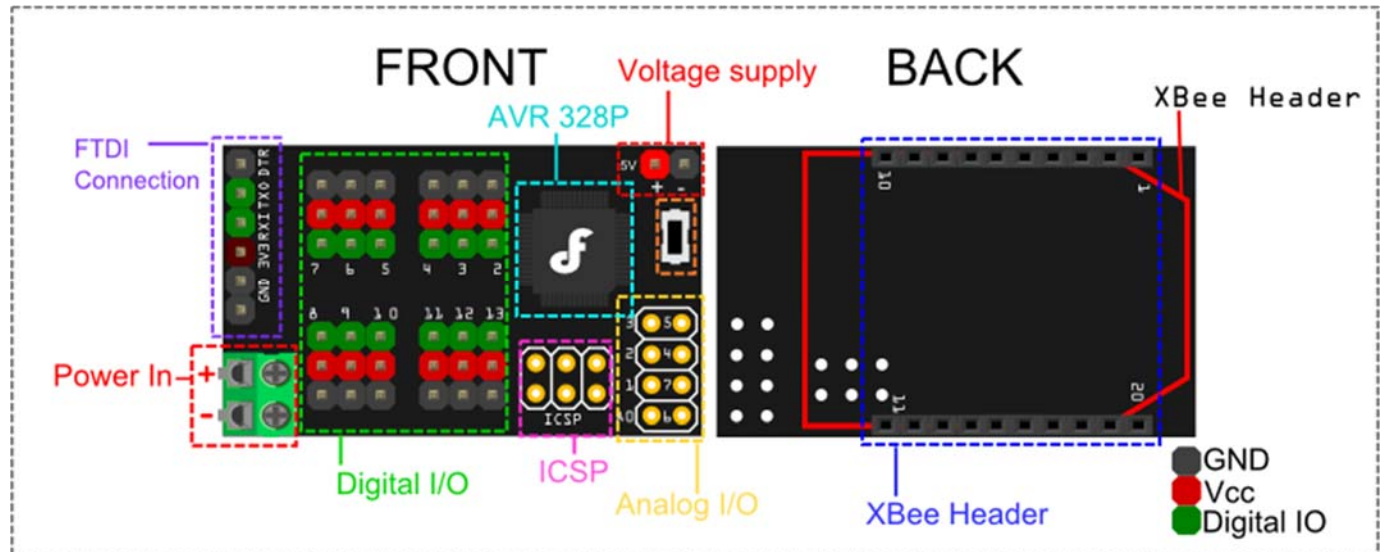

Pin Diagram for DFlyduino

NOTE: Pin "RX" and pin "TX" are on the left side, FTDI interface

## Sample Code

```
#include <MegaServo.h>

#define NBR_SERVOS 12 // the number of servos, up to 48 for Mega, 12 for other boards

#define FIRST_SERVO_PIN 2

MegaServo Servos[NBR_SERVOS] ; // max servos is 48 for mega, 12 for other boards

int pos = 0; // variable to store the servo position
```



```
int potPin = 0;    // connect a pot to this pin.

void setup()
{
  for( int i =0; i < NBR_SERVOS; i++)
    Servos[i].attach( FIRST_SERVO_PIN +i, 800, 2200);
}

void loop()
{
  pos = analogRead(potPin);    // read a value from 0 to 1023
  for( int i =0; i <NBR_SERVOS; i++)
    Servos[i].write( map(pos, 0,1023,0,180));
  delay(15);
}
```

It can be used as a standard mini Arduino board and can control up to 12 servos. For more information, check the Arduino library. <http://arduino.cc/playground/Code/MegaServo>