



Chipsmall Limited consists of a professional team with an average of over 10 year of expertise in the distribution of electronic components. Based in Hongkong, we have already established firm and mutual-benefit business relationships with customers from,Europe,America and south Asia,supplying obsolete and hard-to-find components to meet their specific needs.

With the principle of "Quality Parts,Customers Priority,Honest Operation,and Considerate Service",our business mainly focus on the distribution of electronic components. Line cards we deal with include Microchip,ALPS,ROHM,Xilinx,Pulse,ON,Everlight and Freescale. Main products comprise IC,Modules,Potentiometer,IC Socket,Relay,Connector.Our parts cover such applications as commercial,industrial, and automotives areas.

We are looking forward to setting up business relationship with you and hope to provide you with the best service and solution. Let us make a better world for our industry!



Contact us

Tel: +86-755-8981 8866 Fax: +86-755-8427 6832

Email & Skype: info@chipsmall.com Web: www.chipsmall.com

Address: A1208, Overseas Decoration Building, #122 Zhenhua RD., Futian, Shenzhen, China





MicroSD card module for Arduino (SKU:DFR0229)



Contents

- [1 Introduction](#)
- [2 Specification](#)
- [3 Tutorial](#)
 - [3.1 Diagram](#)
 - [3.2 Sample Code](#)
 - [3.3 Result](#)
- [4 Trouble shooting](#)

Introduction

This is a Micro SD(TF) module from DFRobot. It is compatible with TF SD card (commonly used in Mobile Phone) which is the most tiny card in the market. SD module has various applications such as data logger, audio, video, graphics. This module will greatly expand the capability an Arduino can do with their poor limited memory.

This module has SPI interface and 5V power supply which is compatible with Arduino UNO/Mega. The Pinout is fully compatible with DFRobot's IO Expansion Shield V5.

Specification

- Working Voltage:5V
- Size:20x28mm
- Interface: SPI
- Compatible: MicroSD(TF)

Tutorial

Diagram

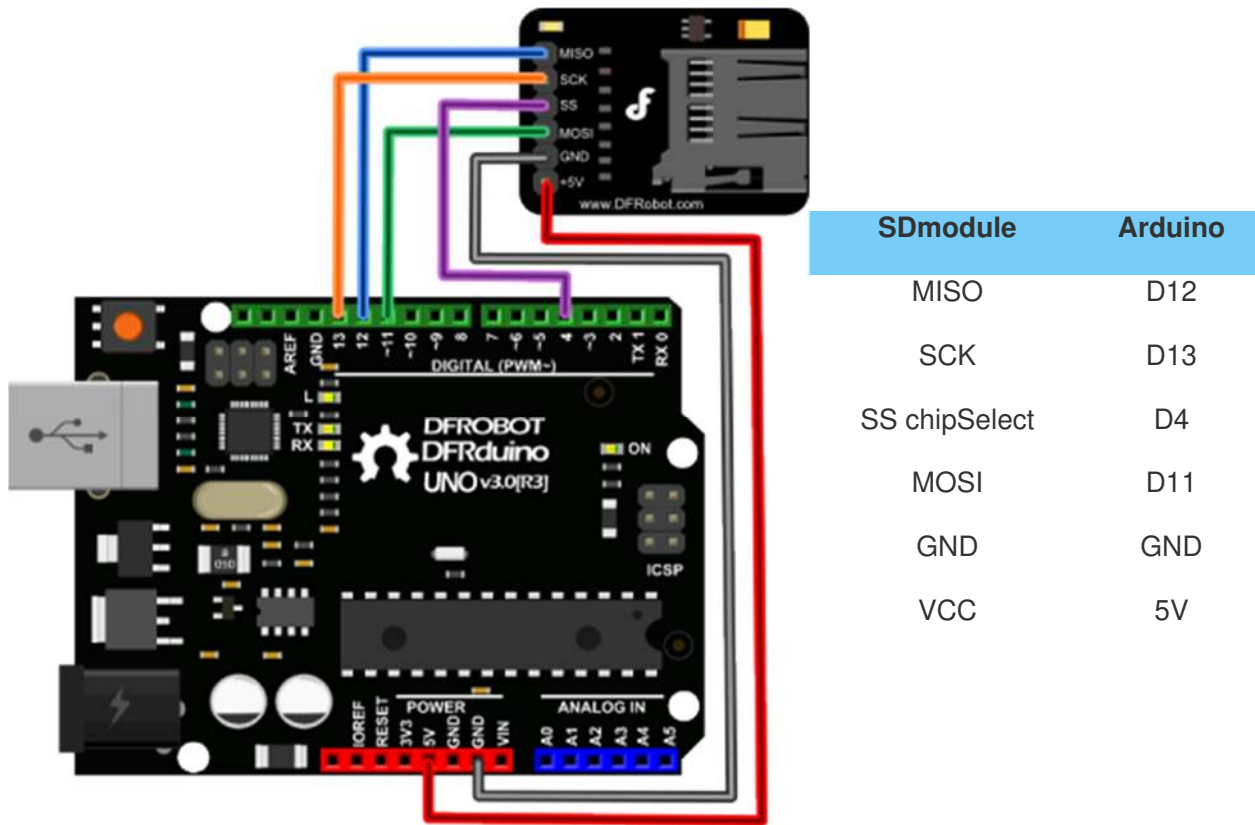

NOTE: Different Boards may have different SPI pin map, please check the datasheet of your controller.

Sample Code

[How to install Library?](#)

Open the sample sketch "CardInfo" in the Arduino IDE. As you can see, it includes the SD library called **SD.h**, you could also download other open source libraries on the web.

```
/*
  SD card test

  This example shows how use the utility libraries on which the
  SD library is based in order to get info about your SD card.
  Very useful for testing a card when you're not sure whether its working or not.

  The circuit:
  * SD card attached to SPI bus as follows:
  ** MOSI - pin 11 on Arduino Uno/Duemilanove/Diecimila
  ** MISO - pin 12 on Arduino Uno/Duemilanove/Diecimila
  ** CLK - pin 13 on Arduino Uno/Duemilanove/Diecimila
  ** CS - depends on your SD card shield or module.
      Pin 4 used here for consistency with other Arduino examples

  created  28 Mar 2011
  by Limor Fried
  modified 9 Apr 2012
  by Tom Igoe
  */

// include the SD library:
#include <SD.h>

// set up variables using the SD utility library functions:
Sd2Card card;
SdVolume volume;
SdFile root;
```

```

// change this to match your SD shield or module;
// Arduino Ethernet shield: pin 4
// Adafruit SD shields and modules: pin 10
// Sparkfun SD shield: pin 8
const int chipSelect = 4;

void setup()
{
  // Open serial communications and wait for port to open:
  Serial.begin(9600);
  while (!Serial) {
    ; // wait for serial port to connect. Needed for Leonardo only
  }

  Serial.print("\nInitializing SD card...");
  // On the Ethernet Shield, CS is pin 4. It's set as an output by default.
  // Note that even if it's not used as the CS pin, the hardware SS pin
  // (10 on most Arduino boards, 53 on the Mega) must be left as an output
  // or the SD library functions will not work.
  pinMode(10, OUTPUT);      // change this to 53 on a mega

  // we'll use the initialization code from the utility libraries
  // since we're just testing if the card is working!
  if (!card.init(SPI_HALF_SPEED, chipSelect)) {
    Serial.println("initialization failed. Things to check:");
    Serial.println("* is a card is inserted?");
    Serial.println("* Is your wiring correct?");
    Serial.println("* did you change the chipSelect pin to match your shield
or module?");
    return;
  } else {
    Serial.println("Wiring is correct and a card is present.");
  }
}

```

```

}

// print the type of card
Serial.print("\nCard type: ");
switch(card.type()) {
  case SD_CARD_TYPE_SD1:
    Serial.println("SD1");
    break;
  case SD_CARD_TYPE_SD2:
    Serial.println("SD2");
    break;
  case SD_CARD_TYPE_SDHC:
    Serial.println("SDHC");
    break;
  default:
    Serial.println("Unknown");
}

// Now we will try to open the 'volume'/'partition' - it should be FAT16 or
FAT32
if (!volume.init(card)) {
  Serial.println("Could not find FAT16/FAT32 partition.\nMake sure you've f
ormatted the card");
  return;
}

// print the type and size of the first FAT-type volume
uint32_t volumesize;
Serial.print("\nVolume type is FAT");
Serial.println(volume.fatType(), DEC);
Serial.println();

volumesize = volume.blocksPerCluster(); // clusters are collections of b
locks

```



```

    volumesize *= volume.clusterCount();           // we'll have a lot of clusters
    volumesize *= 512;                               // SD card blocks are always
512 bytes
    Serial.print("Volume size (bytes): ");
    Serial.println(volumesize);
    Serial.print("Volume size (Kbytes): ");
    volumesize /= 1024;
    Serial.println(volumesize);
    Serial.print("Volume size (Mbytes): ");
    volumesize /= 1024;
    Serial.println(volumesize);

    Serial.println("\nFiles found on the card (name, date and size in bytes): "
);
    root.openRoot(volume);

    // list all files in the card with date and size
    root.ls(LS_R | LS_DATE | LS_SIZE);
}

void loop(void) {

}

```

Result

If your SD card is good and wiring is correct, open the Arduino IDE serial monitor, then you can see your SD card information. Or you might get this warn shown in the right picture.



COM9

Send

```
Initializing SD card...Wiring is correct and a card is present.  
  
Card type: SDHC  
  
Volume type is FAT32  
  
Volume size (bytes): 3723493376  
Volume size (Kbytes): 3636224  
Volume size (Mbytes): 3551  
  
Files found on the card (name, date and size in bytes):  
SYSTEM^1/ 2015-06-01 15:11:36  
INDEXE^1 2015-06-01 15:11:36 76  
MP3/ 2015-06-01 15:11:58  
0001.WAV 2015-06-02 18:26:42 170044  
DATALOG.TXT 2015-07-07 18:20:38 0
```

Autoscroll Both NL & CR 9600 baud

Success

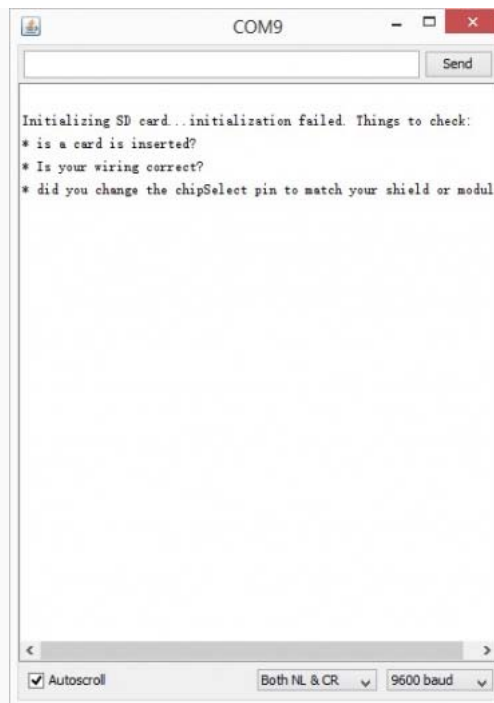

COM9

Send

```
Initializing SD card...initialization failed. Things to check:  
* is a card is inserted?  
* Is your wiring correct?  
* did you change the chipSelect pin to match your shield or modul
```

< >

Autoscroll Both NL & CR 9600 baud

Failure

Trouble shooting

For any questions and more cool ideas to share, please visit [DFRobot Forum](#)