



Chipsmall Limited consists of a professional team with an average of over 10 year of expertise in the distribution of electronic components. Based in Hongkong, we have already established firm and mutual-benefit business relationships with customers from,Europe,America and south Asia,supplying obsolete and hard-to-find components to meet their specific needs.

With the principle of “Quality Parts,Customers Priority,Honest Operation,and Considerate Service”,our business mainly focus on the distribution of electronic components. Line cards we deal with include Microchip,ALPS,ROHM,Xilinx,Pulse,ON,Everlight and Freescale. Main products comprise IC,Modules,Potentiometer,IC Socket,Relay,Connector.Our parts cover such applications as commercial,industrial, and automotives areas.

We are looking forward to setting up business relationship with you and hope to provide you with the best service and solution. Let us make a better world for our industry!



Contact us

Tel: +86-755-8981 8866 Fax: +86-755-8427 6832

Email & Skype: info@chipsmall.com Web: www.chipsmall.com

Address: A1208, Overseas Decoration Building, #122 Zhenhua RD., Futian, Shenzhen, China



LCD1602 RGB Backlight Module

1. FUNCTIONS & FEATURES

Features

- Characters: 16×2 Lines
- LCD Mode: STN, Yellow –Green/Blue/Grayish/Orange;
- LCD Controller IC: AiP31068L or Equivalent
- RGB Controller IC: PCA9633DP2 or Equivalent
- Driving Method: 1/16 Duty; 1/5Bias
- Viewing Angle: 6 O'clock direction
- I²C MPU Interface
- Backlight: RGB LED
- Operating Temperature Range: -20 to +70°C;
- Storage Temperature Range : -30 to +80°C;

2. MECHANICAL SPECIFICATIONS

ITEM	SPECIFICATIONS	UNIT
Module Size	87.0L×32.0W×13.0 (max) H	mm
View Area	64.5×16.0	mm
Number of Character	16×2 Lines	—
Character Size	2.96×5.56	mm
Character Pitch	3.55×5.96	mm

3. EXTERNAL DIMENSIONS

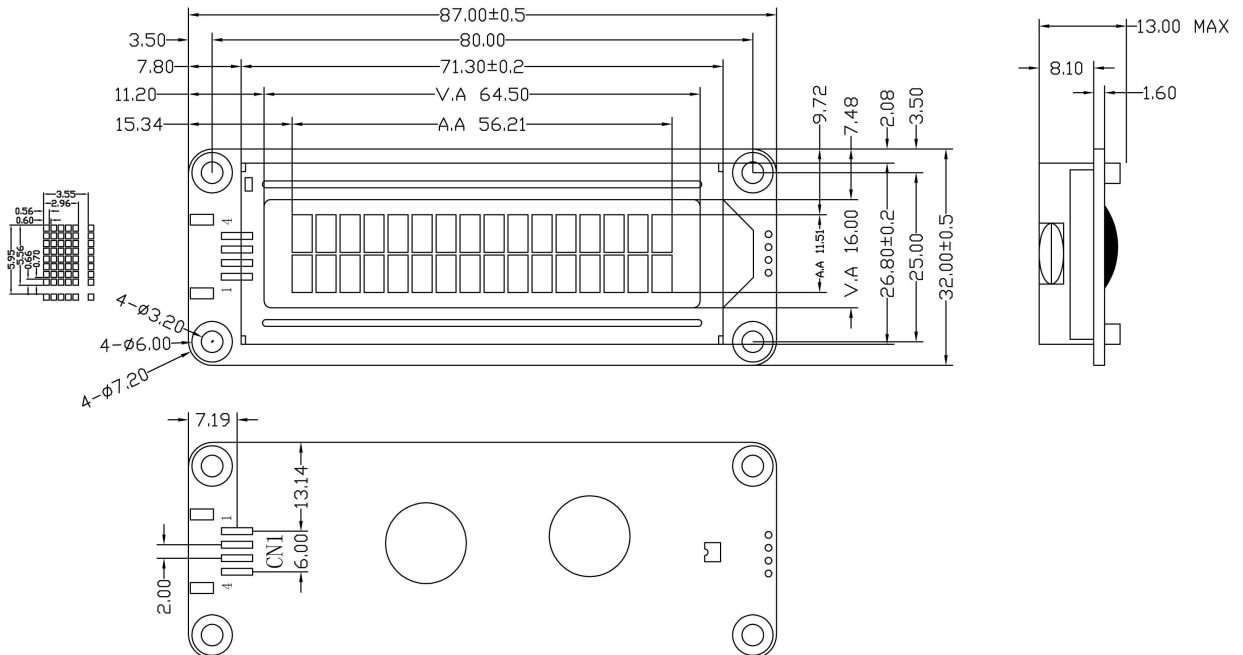

4. BLOCK DIAGRAM

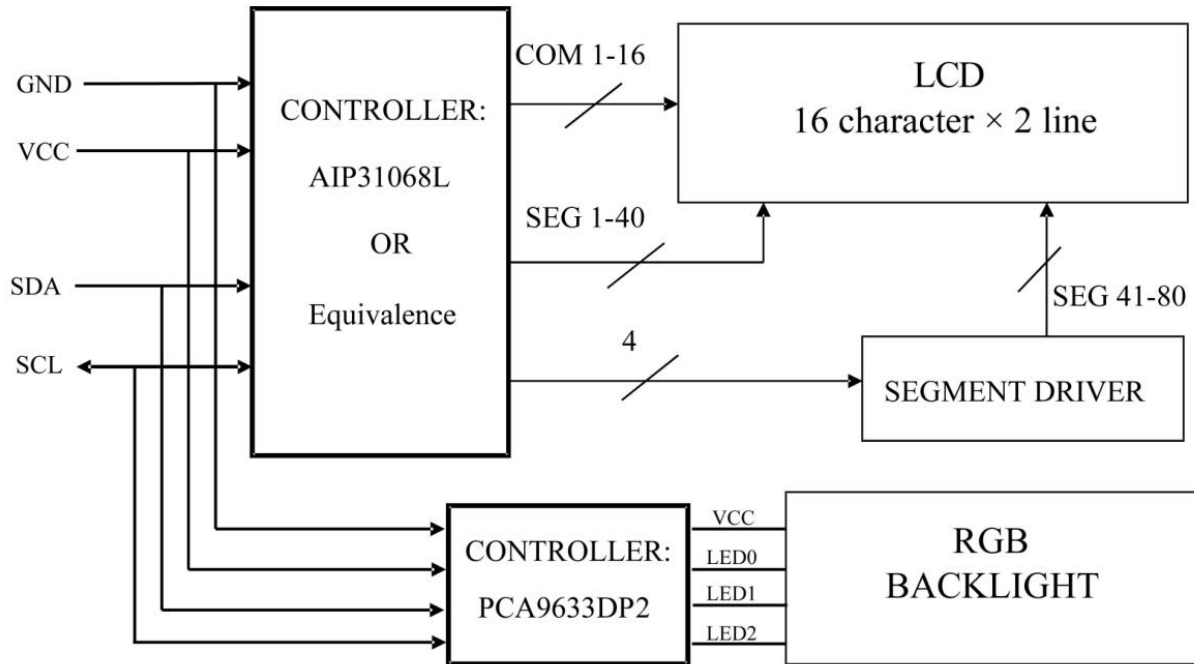

5. POWER SUPPLY

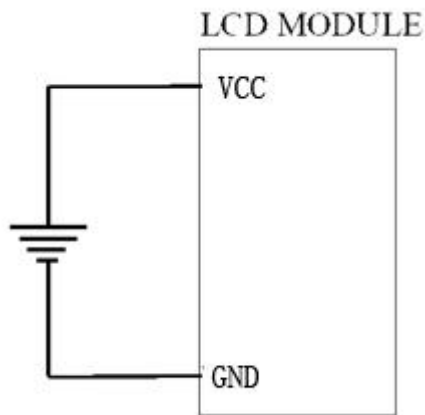

6. PIN DESCRIPTION

ITEM	SYMBOL	LEVEL	FUNCTION
1	SDA	H/L	I ² C-Bus Serial Data
2	SCL	H/L	I ² C-Bus Serial Clock
3	GND	0V	Power Ground
4	VCC	+3.3~5.0V	Power Supply For Logic

7. MAXIMUM ABSOLUTE LIMIT (T=25°C)

Items	Symbol	Min	Max	Unit	Condition
Supply Voltage	Vdd	0	5.2	V	Vss=0V
Input Voltage	Vin	0	Vdd	V	Vss=0V
Operating Temperature	Top	-20	+70	°C	No Condensation
Storage Temperature	Tst	-30	+80	°C	No Condensation

Note: Voltage greater than above may damage the module
 All voltages are specified relative to Vss=0V

8. ELECTRICAL CHARACTERISTICS

8.1 DC Characteristics (VDD=+5.0V, VSS=0V, Ta=-0~+50° C)

Items	Symbol	Test Condition	Min	TYP	Max	Unit
Operating Voltage	V _{DD}		3.0V	—	5.2	V
Supply Current	I _{DD}	Use internal Oscillator/external clock(VDD=5V, fosc=250KHz)	—	0.55	0.8	mA
Input High Voltage 1 (Except OSC1)	V _{IH1}	—	2.5	—	Vdd	V
	V _{IL1}	—	-0.3	—	0.6	
Input High Voltage 2 (Except OSC1)	V _{IH2}	—	Vdd-1.0	—	Vdd	V
	V _{IL2}	—	-0.2		1	V
Output High Voltage 1 (DB0~DB7)	V _{OH1}	I _{OH} =-0.205mA	2.4	—	Vdd	V
	V _{OL1}	I _{OL} =1.2mA	—	—	0.4	V
Output High Voltage 2 (Except DB0~DB7)	V _{OH2}	I _O = -40uA	0.9Vdd	—		V
	V _{OL2}	I _O =40uA	—	—	0.1Vdd	V
Input Leakage Current	I _{IKG}	V _{IN} =0V~VDD	-1	—	1	uA
Input Low Current	I _{IL}	V _{IN} =0V V _{DD} =5V(pull up)	-50	-125	-250	uA
Internal clock(external Rf)	f _{OSC1}	Rf=91K Ω ±2%, VDD=5V	190	270	350	KHz
External clock	f _{OSC}	—	125	270	410	KHz
	duty		45	50	55	%
	t _R , t _F		—		0.2	uS
LCD Driving Voltage	V _{LCD}	V _{DD} .V5(1/5,1/4bias)	3.0	—	11.0	V

8.2 AC Characteristics (VDD=+5.0V, VSS=0V, TTa=-20~70°)

Characteristic	Symbol	Test Condition	Min	TYP	Max	Unit
SCL Cycle Time	f _{SCLK}	I ² C	—	—	400	KHz
SCL Pulse Width	t _{LOW}		1.3	—	—	uS
SCL Rise/Fall Time	t _{HIGH}		0.6	—	—	uS
Address Setup Time	t _{SU:DAT}		100	—	—	nS
Address Hold Time	t _{HD:DAT}		0	—	0.9	uS
SCL/SDA Rise/Pulse Time	t _r , t _f		20	—	300	nS
START Steup Time	t _{SU:STA}		0.6	—	—	uS
START Hold Time	t _{HD:STA}		0.6	—	—	uS
STOP Steup Time	t _{SU:STO}		0.6	—	—	uS
STOP、START Spacing Interval	t _{BUF}		1.3	—	—	uS

MPU write timing

START STOP:

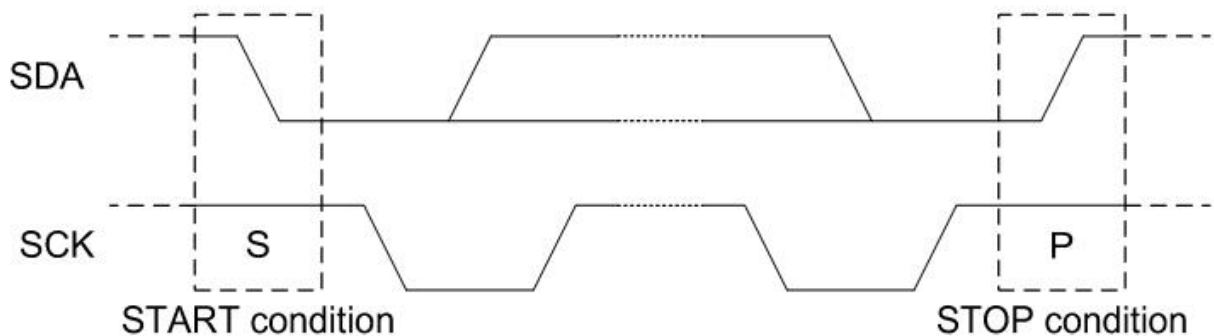

ASK :

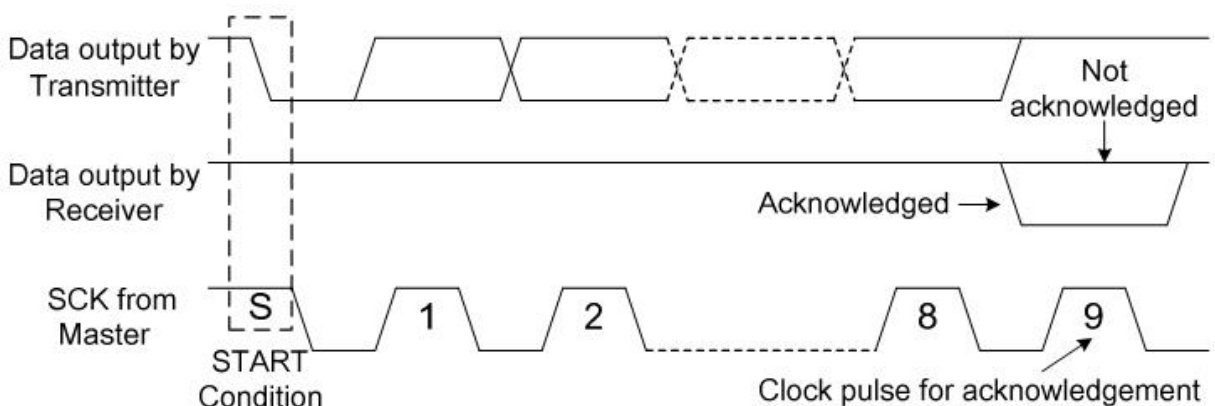

Write Mode (R/W="0")

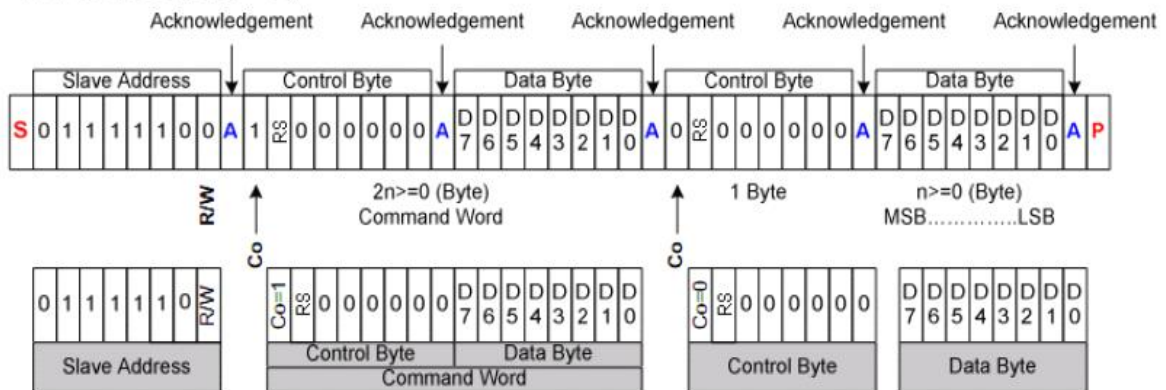

Co	0	Last control byte. Only a stream of data bytes is allowed to follow. This stream may only be terminated by a STOP or RE-START condition.
	1	Another control byte will follow the data byte.

AiP31068L (LCD) Slave Address : 0X7C.

PCA9633DP2 (RGB) Slave Address: 0XC0.

9. FUNCTION SPECIFICATIONS

9.1. Basic Setting

To drive the LCD module correctly and provide normal display, please use the following setting:

- N=1, 2-line display
- F=0, 5 × 8 dots font
- D=1, display on

Note:

- These setting/commands should issue to the LCD module while start up.
- See the Display Commands section for details.

9.2. Resetting The LCD Module

When turning on the VDD and VSS power supply, LCD module will execute the reset routine automatically. It takes about 50ms. After the reset routine, the LCD module status will be as follow:

- N=1, 2-line display
- Display clear

- DL=1, 8-bit interface
- F=0, 5 × 8 dot character font
- D=0, Display off
- C=0, Cursor off
- B=0, Blinking off
- I/D=1, Increment by 1
- S=0, No shift

NOTE:

- Reset routine could not generate the Basic Setting

9.3. Display Memory Map

There are two main memory-areas in the LCD module for display.

- Character Generator RAM(CGRAM)
- Display Data RAM(DDRAM)

9.3.1. Character Generator RAM(CGRAM)

Character Generator RAM is for storing the User-defined Characters(5 × 8 dots font). Totally 8 User-defined Characters(character code = 00h-07h) could be created.

The User-defined Character Codes are 00h and 07h. They could be called into DDRAM as normal character.



User-defined Character Code	CGRAM Address	CGRAM Data (Font Pattern)	
		D7 ~ D5	D4 ~ D0
00h (08h)	00h 01h ⋮ 06h 07h	Not Use	5 x 8 dots font pattern
01h (09h)	08h 09h ⋮ 0Eh 0Fh	Not Use	5 x 8 dots font pattern
02h (0Ah)	10h 11h ⋮ 16h 17h	Not Use	5 x 8 dots font pattern
03h (0Bh)	18h 19h ⋮ 1Eh 1Fh	Not Use	5 x 8 dots font pattern
04h (0Ch)	20h 21h ⋮ 26h 27h	Not Use	5 x 8 dots font pattern
05h (0Dh)	28h 29h ⋮ 2Eh 2Fh	Not Use	5 x 8 dots font pattern
06h (0Eh)	30h 31h ⋮ 36h 37h	Not Use	5 x 8 dots font pattern
07h (0Fh)	38h 39h ⋮ 3Eh 3Fh	Not Use	5 x 8 dots font pattern

CGRAM Address Map

9.3.2. Character code ROM

Please refer to AiP31068L datasheet.

9.4. Display Commands

Instruction	RS	D7	D6	D5	D4	D3	D2	D1	D0	Execution time fosc=270KHz	Description
Clear Display	0	0	0	0	0	0	0	0	1	1.53ms	Write "20H" to DDRAM and set DDRAM address to "00H" from AC
Return Home	0	0	0	0	0	0	0	1	-	1.53ms	Set DDRAM address to "00H" from AC and return cursor to its original position if shifted. The contents of DDRAM are not changed.
Entry Mode Set	0	0	0	0	0	0	1	I/D	SH	39us	Assign cursor moving direction and enable the shift of entire display
Display ON/ OFF Control	0	0	0	0	0	1	D	C	B	39us	Set display (D), cursor(C), and blinking of cursor(B) on/off control bit.
Cursor or Display Shift	0	0	0	0	1	S/C	R/L	-	-	39us	Set cursor moving and display shift control bit, and the direction, without changing of DDRAM data.
Function Set	0	0	0	1	-	N	F	-	-	39us	Set numbers of display line (N: 2-line/1-line) and, display font type (F:5x10 dots/5x8 dots)
Set CGRAM Address	0	0	1	AC5	AC4	AC3	AC2	AC1	AC0	39us	Set CGRAM address in address counter.
Set DDRAM Address	0	1	AC6	AC5	AC4	AC3	AC2	AC1	AC0	39us	Set DDRAM address in address counter
Write Data to RAM	1	D7	D6	D5	D4	D3	D2	D1	D0	43s	Write data into internal RAM (DDRAM/CGRAM).

NOTE:

- Do not use any other commands not listed, or the system malfunction may result.
- For the details of rte display commands, please refer to AiP31068L datasheet.

10. DESIGN AND HANDLING PRECAUTION

- 10.1. The LCD panel is made by glass. Any mechanical shock (eg. Dropping from high place) will damage the LCD module. Do not add excessive force on the surface of the display, which may cause the Display color change abnormally.
- 10.2. The polarizer on the LCD is easily get scratched. If possible, do not remove the LCD protective film until the last step of installation.
- 10.3. Never attempt to disassemble or rework the LCD module.
- 10.4. Only Clean the LCD with Isopropyl Alcohol or Ethyl Alcohol. Other solvents (eg. water) may damage the LCD.

- 10.5. When mounting the LCD module, make sure that it is free from twisting, warping and distortion.
- 10.6. Ensure to provide enough space (with cushion) between case and LCD panel to prevent external force from adding on it, or it may cause damage to the LCD or degrade the display result.
- 10.7. Only hold the LCD module by its side. Never hold LCD module by adding force on the heat seal or TAB.
- 10.8. Never add force to any component of the LCD module. It may cause invisible damage or degrade the reliability.
- 10.9. LCD module could be easily damaged by static electricity. Be careful to maintain an optimum anti-static work environment to protect the LCD module.
- 10.10. When peeling off the protective film from LCD, static charge may cause abnormal display patterns. It is normal and will return to normal in a short while.
- 10.11. Take care and prevent getting hurt by the LCD panel edge.
- 10.12. Never operate the LCD module beyond the absolute maximum ratings.
- 10.13. Keep the signal lines as short as possible to prevent noisy signals from applying to the LCD module.
- 10.14. Never apply signals to the LCD module without a power supply.
- 10.15. IC chips (e.g. TAB or COG) are sensitive to light. Strong lighting environments could possibly cause malfunctions. Light-sealing structure casing is recommended.
- 10.16. LCD module reliability may be reduced by temperature shock.
- 10.17. When storing the LCD module, avoid exposure to direct sunlight, high humidity, high temperature or low temperature. They may damage or degrade the LCD module.