



Chipsmall Limited consists of a professional team with an average of over 10 year of expertise in the distribution of electronic components. Based in Hongkong, we have already established firm and mutual-benefit business relationships with customers from,Europe,America and south Asia,supplying obsolete and hard-to-find components to meet their specific needs.

With the principle of “Quality Parts,Customers Priority,Honest Operation,and Considerate Service”,our business mainly focus on the distribution of electronic components. Line cards we deal with include Microchip,ALPS,ROHM,Xilinx,Pulse,ON,Everlight and Freescale. Main products comprise IC,Modules,Potentiometer,IC Socket,Relay,Connector.Our parts cover such applications as commercial,industrial, and automotives areas.

We are looking forward to setting up business relationship with you and hope to provide you with the best service and solution. Let us make a better world for our industry!



## Contact us

Tel: +86-755-8981 8866 Fax: +86-755-8427 6832

Email & Skype: info@chipsmall.com Web: www.chipsmall.com

Address: A1208, Overseas Decoration Building, #122 Zhenhua RD., Futian, Shenzhen, China



## Gravity: Digital Peristaltic Pump SKU: DFR0523



### Introduction

Gravity: digital peristaltic pump is a new product developed by DFRobot. This is a new member of our water quality monitoring devices. It is an actuator for the liquid system.

DFRobot peristaltic pump integrates a PPM motor driver on the pump, this is a Gravity interface (PH2.0-3P) motor driver. The control signal is compatible with standard servo motor, you can use Arduino, Raspberry Pi, micro:bit and other kinds of microcontrollers to control its direction and flow speed. The tube in the pump head is made up of BPT material, which is anti-acid and long life. Peristaltic pumps are a kind of positive displacement pump used for delivering small amounts of fluid. The fluid is contained within a flexible tube fitted inside a circular pump casing. When the rotor rotates continuously, the fluid in the tube will be squeezed and deliver to the other side. In this way, the liquid flow rate can be easily accuracy controlled.

As a kind of metering pump, peristaltic pump can be conveniently used for quantitative delivery. It has a wide range of application scenarios, such as science experiment, hydroponics, drip irrigation, tropical fish farming, shrimp cylinder environment control, etc. A large number of titration experiments can be automated with this peristaltic pump, such as potentiometric titration, indicator-based colorimetric titration, pH-based titration, and so on. It is great helpful to improve your working efficiency. On the other hand, peristaltic pumps also have a wide range of applications in food, medical and other industries. Making an automatic coffee machine will be a really good idea!

# Specification

Driver Board:

- **Input Voltage: 5V-6V**
- **Maximum Continuous Operating Current: 1.8A**
- **Peak Current: 2.5A**
- **Quiescent Current: <1mA (No PPM Signal Input)**
- **PPM Signal Resolution: 1us**
- **Positive Pulse Width of the PPM Signal: 500us-2500us**
- **Forward Pulse Width Range: 500us-1400us (500us: max forward speed)**
- **Stop Pulse Width Range: 1400us-1600us**
- **Inverted Pulse Width Range: 1600us-2500us (2500us: max inverted speed)**
- **PPM Frequency: 50Hz (Servo Control Signal)**
- **Connector: Gravity PH2.0-3P**
- **Size: 27.4 x 28.7 mm/1.08 x 1.13 inches**

Peristaltic Pump

- **Motor: DC Motor**
- **Rated Voltage: 6V**
- **Rated Power: 5W**
- **Tube Material: BPT**
- **Tube Specifications: inner diameter 2.5mm, outer diameter 4.5mm**
- **Pump Head Material: Engineering Plastics**
- **Pulsation: Three Rollers, Small Pulsation**
- **Flow:  $\geq 45\text{ml/min}$  (almost  $1\text{ml/s}$ )**
- **Working Conditions: ambient temperature  $0 \sim 40 \text{ }^\circ\text{C}$ , relative humidity  $<80\%$**

## Board Overview

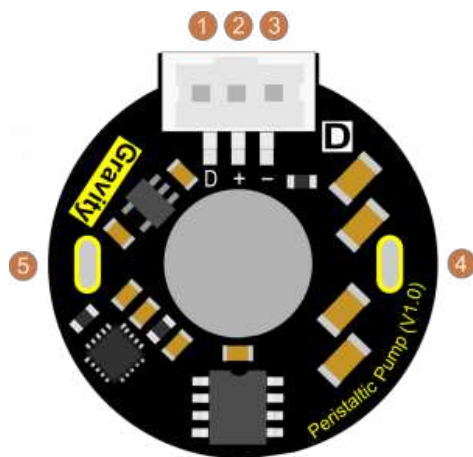

Num	Label	Description
1	D	Control Signal Input(PPM Signal)
2	+	Power VCC(5V~6V)
3	-	Power GND(0V)
4	M-	Motor Negative Pin
5	M+	Motor Positive Pin

Gravity: Peristaltic Pump SKU:DFR0523



# Basic Tutorial



Since the motor power consumption (about 5W) is a little large, it's better to add an external power supply on your microcontroller, USB port can only provide 2.5W power supply.

This tutorial will demonstrate how to make this peristaltic pump clockwise rotation, stop rotation, counterclockwise rotation of these three basic functions.

The motor driver board uses the PPM signal to control the pump. The corresponding relationship is as follows:

PPM Signal	Peristaltic Pump Status (Top View)
500~1400us (0~81°)	Clockwise maximum speed rotation
1400~1600us (81~99°)	Stop
1600~2500us (99~180°)	Counterclockwise maximum speed rotation

In addition, the closer to 500us(0°) or 2500us(180°), the faster the flow rate speed is; when the value is closer to 90°, the slower the motor speed. Therefore, according to the requirement, you can set the appropriate angle value to adjust the motor speed, to achieve the purpose of controlling the flow rate.

## Requirements

- Hardware
  - DFRduino UNO R3 (or similar) x 1
  - Motor of Peristaltic Pump x 1
  - Pump Head of Peristaltic Pump x1
  - External Power(5~7V) x1
  - Digital 3Pin Gravity Cable x1
- Software
  - Arduino IDE (Version requirements: V1.0.x or V1.8.x), [Click to Download Arduino IDE from Arduino®](#)

## Connection Diagram

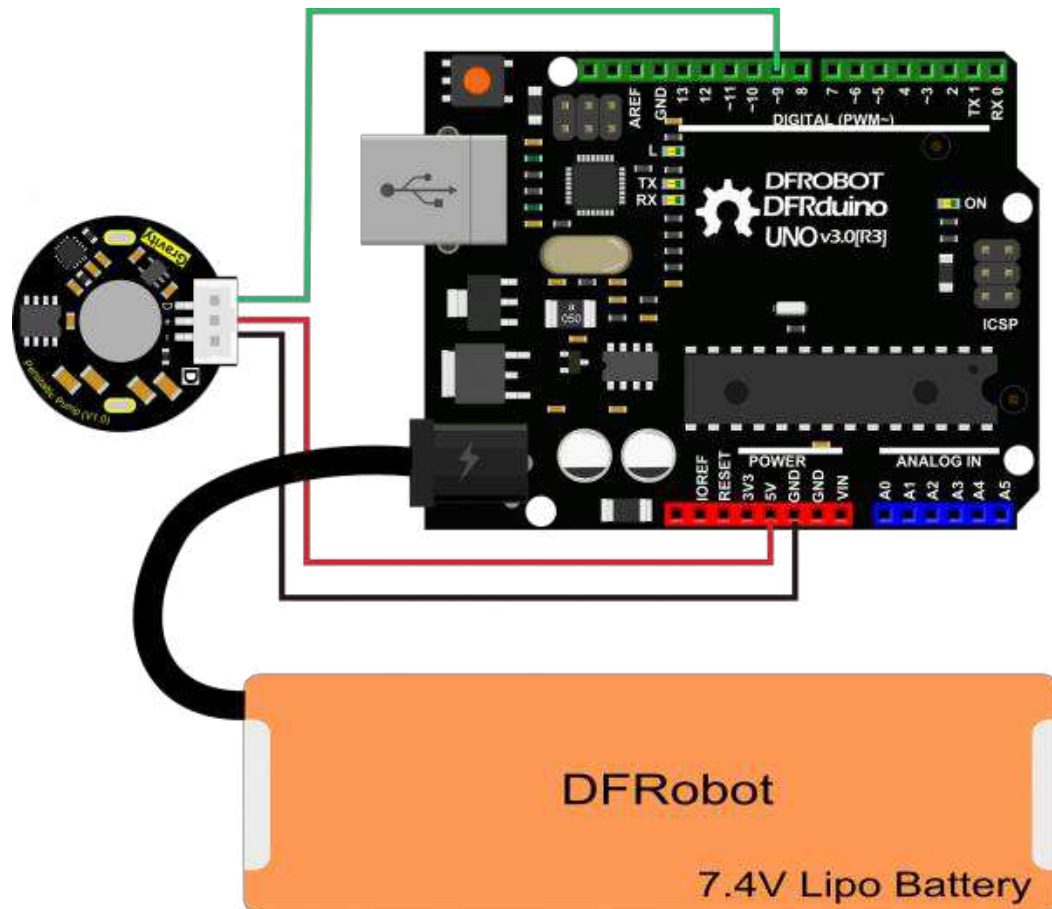

## Arduino Sample Code

```
/*  
DFRobot Gravity: Peristaltic Pump  
<https://www.dfrobot.com/wiki/index.php/Gravity: Peristaltic Pump SKU:DFR0523>  
*/
```

```

*****

This sample code shows 3 states: clockwise maximum speed rotation; stop;
counterclockwise maximum speed rotation

Created 2017-12-25
By Jason <jason.ling@dfrobot.com@dfrobot.com>

GNU Lesser General Public License.
See <http://www.gnu.org/licenses/> for details.
All above must be included in any redistribution
*****/

/*****Notice and Trouble shooting*****/
0 -> clockwise maximum speed rotation
90 -> stop
180 -> counterclockwise maximum speed rotation
*****/

#include <Servo.h>

Servo myservo;

#define PUMPPIN 9 //peristaltic pump control pin, connect to arduino di
gital pin 9
#define waitTime 2000 //interval time(ms) between every state

void setup()
{
  myservo.attach(PUMPPIN);
}

void loop()
{
  myservo.write(0); //Clockwise maximum speed rotation
  delay(waitTime);
}

```

```
myservo.write(90); //Stop
delay(waitTime);
myservo.write(180); //Counterclockwise maximum speed rotation
delay(waitTime);
myservo.write(90); //Stop
delay(waitTime);
}
```

## micro:bit Sample Code

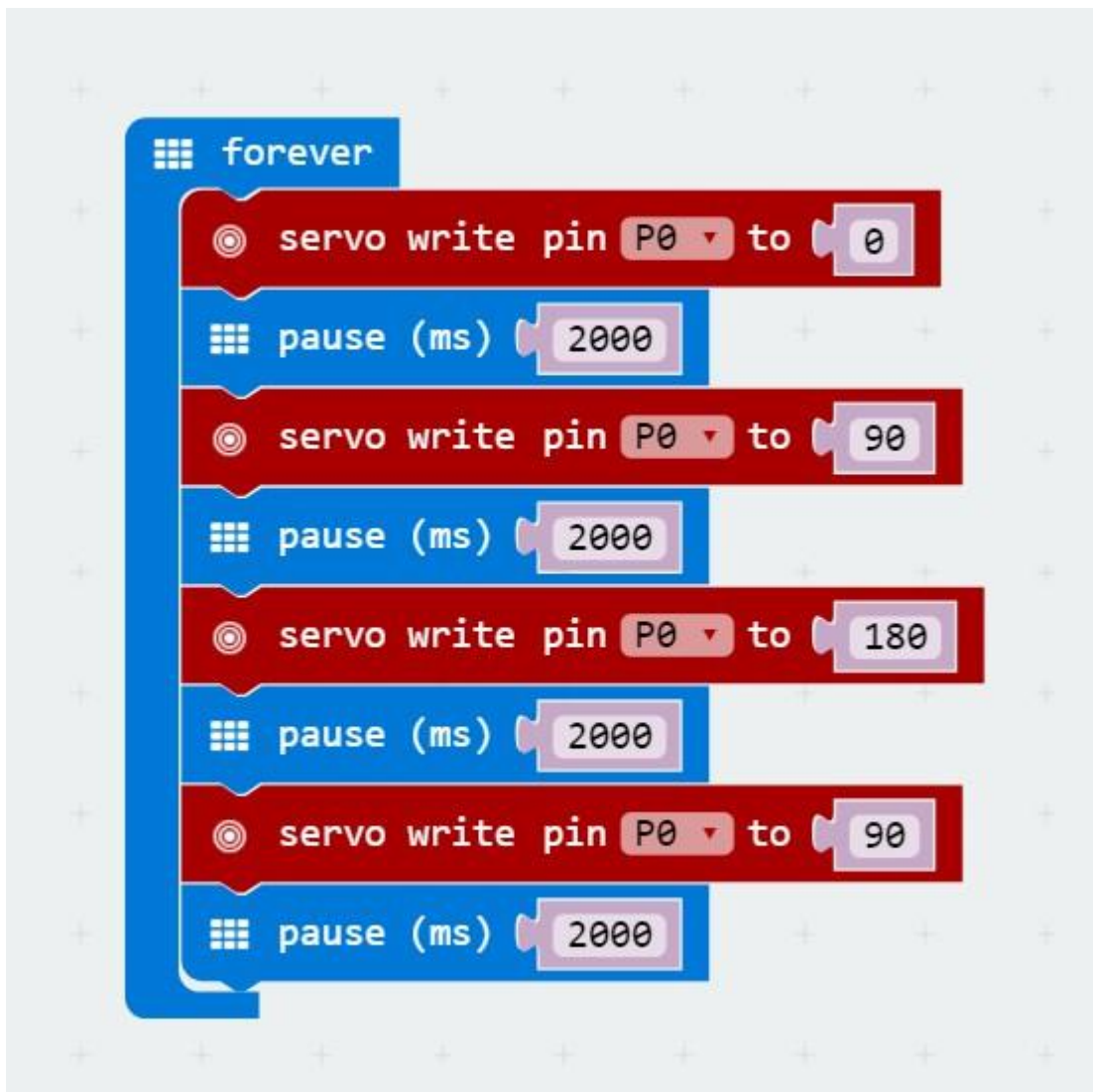

## Expected Results

After uploading the sample code, you can see that the peristaltic pump starts to work and continuously switches between the three states of clockwise maximum speed rotation, stop and maximum counterclockwise rotation speed every 2 seconds.

For any questions, advice or cool ideas to share, please visit the [DFRobot Forum](#).

## More Documents

- [Motor Driver Board Dimension](#)
- [Peristaltic Pump Dimension](#)