



Chipsmall Limited consists of a professional team with an average of over 10 year of expertise in the distribution of electronic components. Based in Hongkong, we have already established firm and mutual-benefit business relationships with customers from,Europe,America and south Asia,supplying obsolete and hard-to-find components to meet their specific needs.

With the principle of “Quality Parts,Customers Priority,Honest Operation,and Considerate Service”,our business mainly focus on the distribution of electronic components. Line cards we deal with include Microchip,ALPS,ROHM,Xilinx,Pulse,ON,Everlight and Freescale. Main products comprise IC,Modules,Potentiometer,IC Socket,Relay,Connector.Our parts cover such applications as commercial,industrial, and automotives areas.

We are looking forward to setting up business relationship with you and hope to provide you with the best service and solution. Let us make a better world for our industry!



Contact us

Tel: +86-755-8981 8866 Fax: +86-755-8427 6832

Email & Skype: info@chipsmall.com Web: www.chipsmall.com

Address: A1208, Overseas Decoration Building, #122 Zhenhua RD., Futian, Shenzhen, China





Sunflower: Solar Power Manager SKU: DFR0535

Sunflower Solar Power Series

Introduction

DFRobot Sunflower is a brand new series focusing on high-efficiency micro to middle power solar energy harvesting and management for makers, renewable energy and IoT projects. All Sunflower modules feature as MPPT (Maximum Power Point Tracking) maximizing solar collection efficiency under different sun light, and a variety of battery and power protections. These features provide makers' solar projects efficient and reliable power management.

Selection Guide

Name	<u>Solar Power Manager</u> ★	<u>Solar Power Manager 5V</u>
SKU	DFR0535	DFR0559
Solar Power Management IC	LTC3652	CN3065
Solar Input Voltage	7V ~ 30V	4.4V ~ 6V
Maximum Charge Current	2A	900mA
Topology	DC-DC Buck	Linear Regulator
Battery	3.7V Lithium Battery	3.7V Lithium Battery
MPPT	Yes (9V/12V/18V Optional)	Yes (Fixed 5V)
Battery Protections	Over Charge/Over Discharge/Over Current/Reverse Connection Protections	Over Charge/Reverse Connection Protections
Output Protections	Short Circuit/Over Current/Over Heat Protections	Short Circuit/Over Current Protections
USB Charge IN	Yes	Yes
USB OUT	5V 1.5A	5V 1A
Regulated OUT	Three Regulated Outputs 3.3V 1A ; 5V 1.5V ; 9V/12V 0.5A	One Regulated Output 5V 1A
Dimension	78.0mm×68.0mm	33.0mm×63.0mm
Features	A complete multifunction solar power management module. Applications: Small Solar Street Lamp, Solar Powered Robots For 9V/12V/18V Solar Panels within 20W	A small and easy-to-use 5V solar power management module. Applications: Solar Power Bank, Solar Environment Monitors For 5V Solar Panels within 10W

Introduction

DFRobot Sunflower focuses on high-efficiency small power solar energy harvesting and management for IoT projects and renewable energy applications. Solar Power Manager is a complete small power and high-efficiency solar power management module. It features as MPPT (Maximum Power Point Tracking) function, maximizing the efficiency of the solar panel. Apart from serving as a solar charger, the module can provide up to 2A charging current to 3.7V Li battery with AC adapter (within 30V) or USB charger, three individual ON/OFF controllable DC-DC converters with 5V 1.5A, 3.3V 1A and 9V/12V 0.5A outputs. These features satisfy the needs of various solar power projects and low-power applications. The module also employs various protection functions, such as Li battery protection, battery/solar panel reverse connection protection, output over temperature and over current/short circuit protection, which greatly improves the stability and safety of the system.

Features

- Constant Voltage MPPT Algorithm, Maximizing Solar Panel Efficiency
- 7V~30V Wide Solar Panel Input Voltage
- Various Charging Mode: Solar/AC Adapter/USB Charger (2A Max Charge Current)
- Three Individual ON/OFF Controllable Regulated Power Supply for Low-Power Applications
- All Multi-Layer Ceramic Capacitors (MLCC), Safe, Stable and High-Efficiency
- Various Protection Functions
- USB Connector with ESD Shell

Specifications

- Solar Power Management IC: LTC3652
- Solar Input Voltage (SOLAR IN) : 7V~30V
- Battery Input (BAT IN): 3.7V Li-Polymer/Li-ion Battery
- Charge Current (USB/SOLAR IN): 2A Max Trickle Charging, Constant Current, Constant Voltage Three Phases Charging
- Charge Cutoff Voltage (USB/SOLAR IN): 4.2V±1%
- MPPT Setting Voltages : OFF/9V/12V/18V
- USB IN Voltage : 5V
- Regulated Power Supply : OUT1=5V 1.5A; OUT2=3.3V 1A; OUT3=9V/12V 0.5A
- Regulated Power Supply Efficiency (3.7V battery IN)
- OUT1: 90%@10%Load, 86%@50%Load, 80%@90%Load
- OUT2: 96%@10%Load ; 92%@50%Load ; 87%@90%Load
- OUT3 (9V OUT): 88%@10%Load, 89%@50%Load, 86%@90%Load
- OUT3 (12V OUT): 87%@10%Load, 88%@50%Load, 82%@90%Load
- USB Charge Efficiency: 84%@1A ; 74%@1.8A
- Solar Charge Efficiency (18V SOLAR IN) : 78%@1A ; 72%@1.8A
- Maximum Quiescent Current:
- Overall : <3 mA
- OUT1: <760 uA
- OUT2: <560 uA
- OUT3: <1.72 mA
- Protections
- BAT IN: Over Charge Voltage (4.3V)/Over Discharge Voltage (2.4V) /Over Current (3A) /Reverse Connection Protection
- OUT1-OUT3/USB OUT: Short Circuit/Over Current/Over Heat Protection
- SOLAR IN: Reverse Connection Protection
- Operation Temperature : -40°C~85°C
- Dimension : 78.0mm*68.0mm

Applications

- Smart Solar Environment Monitor System
- Solar Powered Robot
- Small Solar Street Lamp
- Solar Power Bank

Board Overview

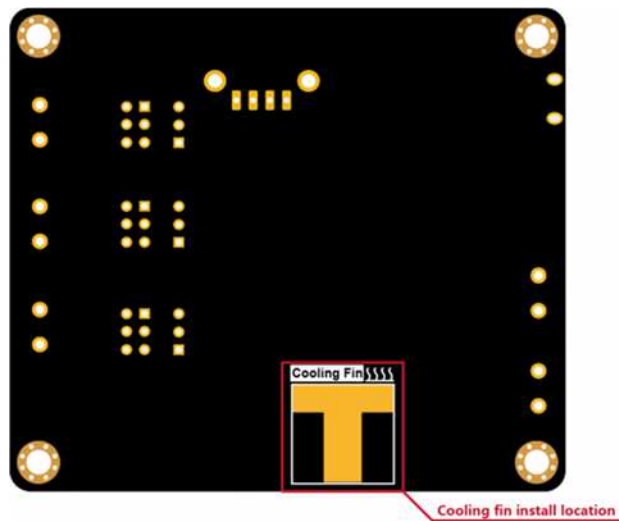
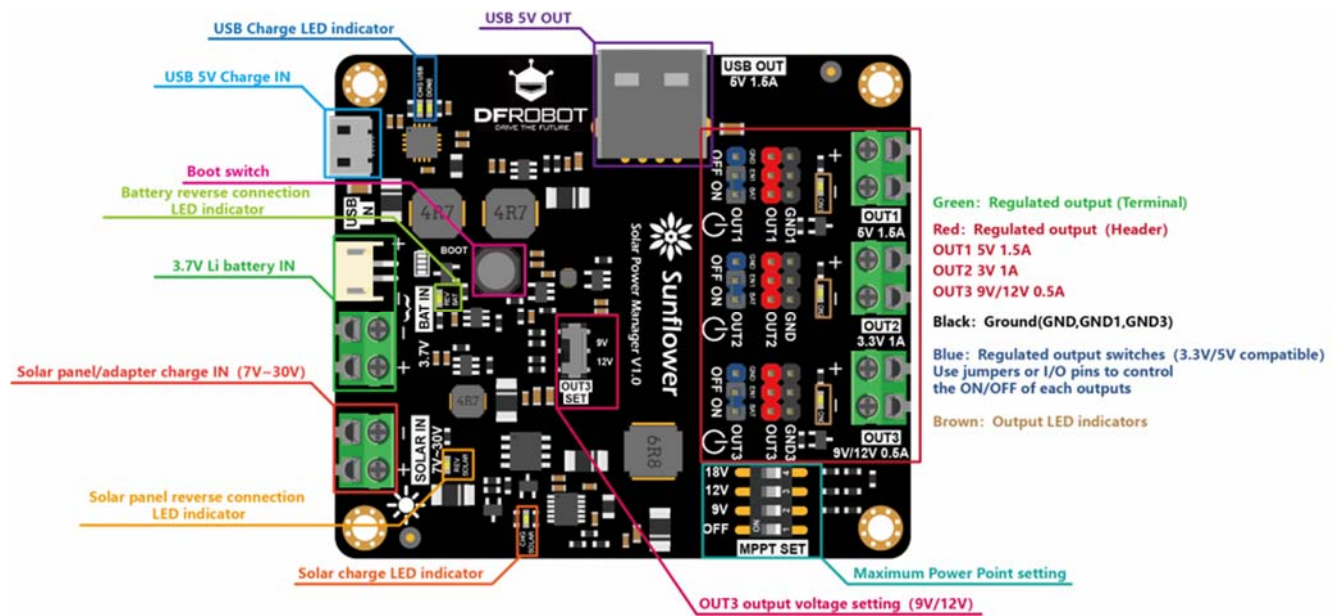

Quick Start

Build a solar powered system

- Connect the Li battery to BAT IN.
- Connect the solar panel to SOLAR IN.
- Connect USB OUT of the module to Arduino with USB cable.
- Switch one bit of the MPPT SET to ON (others remain OFF) according to the nominal (maximum power point) voltage of the solar panel.
- Connect USB OUT of the module to Arduino with USB cable.
- Connect all the VCC and GND pins of the peripherals to the regulated power supply headers or terminals according to the nominal voltage.
- Press the BOOT button for once to activate the Li battery protection IC.

Attention

If a 10W (or above) solar panel is used, the LTC3652 may run in full load, trying to charge the battery at maximum 2A. In order to improve the cooling of the IC, it is highly recommended to attach the **thermal conductive silicone pad** and **Aluminum cooling fin** (included in the kit) to the bottom of the module where the label "Cooling Fin" is located.

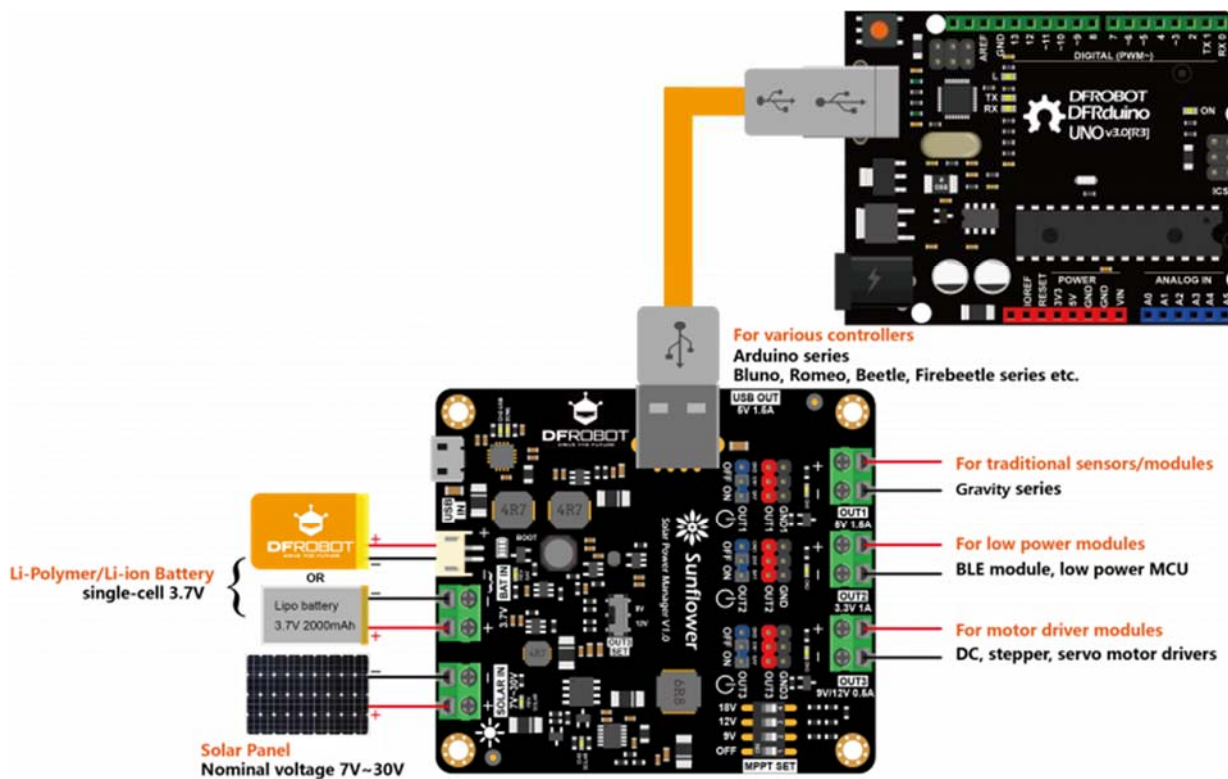

Solar powered system

Detailed Description

Maximum Power Point Tracking, MPPT

The **MPPT (Maximum Power Point Tracking)** can ensure the solar panel output power maintains at its maximum under different loads and sunlight, maximizing the conversion efficiency. We can identify the short circuit current I_{SC} and the open circuit voltage V_{OC} from the cross points of the I/V curve (green) with x and y axis respectively. The I_{SC} and V_{OC} grow larger with the illumination increasing. With the output voltage V_{PANEL} growing, the output current I_{PANEL} gradually decreases and then jumps down after crosses a special point V_{MP} , the maximum power voltage. By multiplying the voltage and current, which obviously results in power, and take the output voltage as the x axis, we obtain the P/V curve (blue). The output power P_{PANEL} reaches its peak when the output voltage is at V_{MP} . Although the maximum power increases with illumination, the V_{MP} changes little. Therefore, we may approximately take the V_{MP} as a constant for a specific solar panel under different illumination.

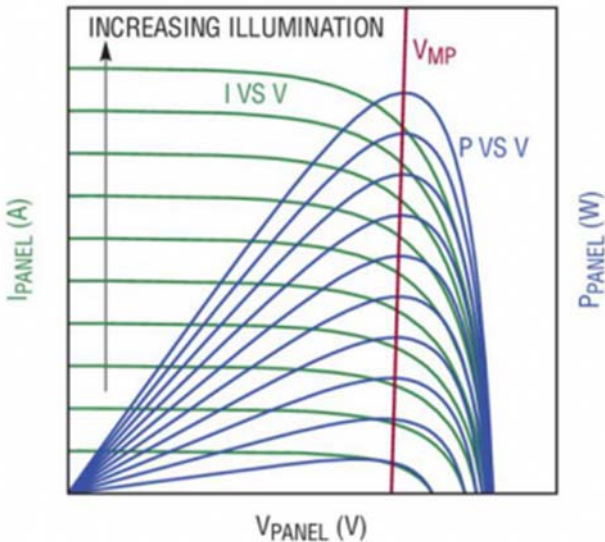

IV/PV characteristic curve of a typical solar panel (picture from Linear Technology)

Inspired by the observation above, the LTC3652 solar power management IC (employed by this module) maximizes the output power by keeping the output voltage at the vicinity of V_{MP} , which is also called **constant voltage MPPT algorithm**. Benefited from this feature, the module has a better conversion efficiency compared to common solar battery charger.

Solar Panel Selection

Users can plug in any kinds of solar panel (monocrystal, polycrystal, thin film) as long as the **open circuit voltage** within 7V~30V. Taking the size, weight, price of the panel and the 2A maximum charge current of the module all these factors into consideration, it is recommended to connect a solar panel with no more than 20W to the SOLAR IN terminal.

 The input voltage of SOLAR IN SHOULD NOT exceed 30V, or the module may be permanently damaged.

MPPT SET

MPPT SET provides quick setting of the MPPT voltage. Three commonly used solar panel voltage 9V, 12V and 18V are available. Switch one bit of the 4P DIP switch (others remains OFF) according to the nominal voltage of the panel. To disable the MPPT function, switch the last bit (the OFF bit, label No. 1) to ON. This bit has the top priority. Once it is at ON, the MPPT function will be disabled no matter the status of other bits. By disabling MPPT function, The SOLAR IN becomes a buck type DC-DC Li battery charger

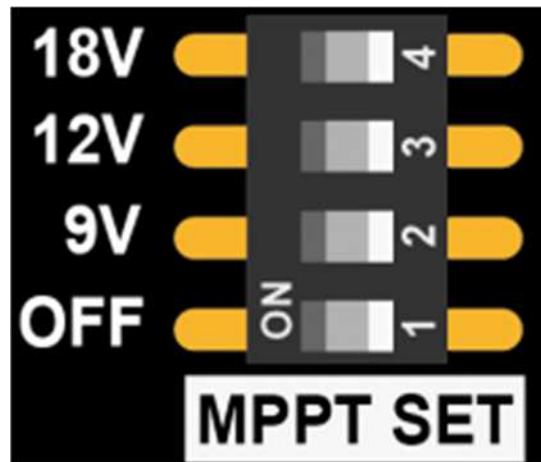

MPPT SET DIP switch

Attention

If the sunlight is too weak, the open circuit voltage of the panel may be below the MPPT voltage. The SOLAR IN can not charge the battery under such condition, but users can still turn off the MPPT function to continue charging the battery with small current.

Battery Selection

The battery input BAT IN provides two connectors JST PH2.0 and KF301 5.08mm 2P terminal, which directly connect each other internally. Usually, connect **one 3.7V Li-polymer/Li-ion battery (4.2V when fully charged)** to one of the connectors. The maximum charge current can be up to 2A for USB IN or SOLAR IN. Safety issue may arise if the charging current exceeds the nominal charge current of the battery, which is often determined by the capacity and charge rate of a battery. The maximum allowable charge current of a battery can be calculated with the equation: Maximum charge current(mA) = Capacity(mAH) * Charge rate(C). Use this equation to check whether the battery is suitable. For commonly used 1C (charge rate) Li battery, the capacity should be at less 2000mAh. For higher charge rate battery, smaller capacity can be used. Some Li batteries are packed with battery protection circuit to automatically limit the charge/discharge current. For such batteries, users are free of worrying about the charge current issue stated above.



DO NOT use nonchargeable battery or chargeable battery not described above.

USB Charge Requirement

The USB IN is only used for battery charging. It is recommended to use a 5V 2A AC adapter for battery charging. Lower capacity adapter, such as 5V 1A, may increase the charging period.

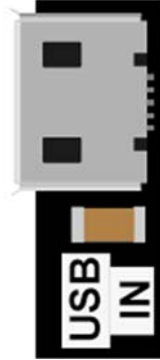

USB IN charge input

USB/SOLAR IN Automatic Switching

Both the USB IN and SOLAR IN are capable of deliver 2A max charge current. To prevent charge conflict caused by using both inputs, the USB charge has a higher priority. When the USB IN is powered on by AC adapter, the SOLAR IN will be automatically cut off. When the USB IN is powered down, the SOLAR IN resumes charging.

Regulated Power Supply

The module provides three individual regulated outputs OUT1/USB OUT=5V 1.5A, OUT2=3.3V 1A, OUT3=9V/12V 0.5A. Output voltage of OUT3 can be set as 9V or 12V through the switch **OUT3 SET**. OUT1 and USB OUT share the same output voltage and maximum current, but USB OUT CAN NOT be shutdown.

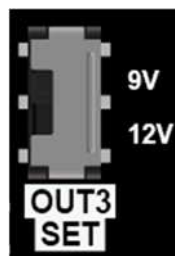

OUT3 output voltage setting switch

Most of the power banks available on the market has the automatic shutdown function to reduce the quiescent power under light loads. However, the automatic shutdown threshold is usually higher than many low power controllers, some even higher than the classical Arduino UNO (around 50mA). Such power banks will automatically shut itself down when the output current continues lower than some preset threshold after several seconds, which fails to apply to low power applications. The USB OUT employs the low quiescent power DC-DC boost converter and always remains ON to provide continuous power to low power controller.

Except from USB OUT, the OUT1-OUT3 can be turned ON/OFF by all 3.3V and 5V controllers (such as Arduino, FireBeetle or Raspberry Pi etc.). Pull out the jumper on the blue header, the corresponding output will be shutdown (LED indicator ON turns dark). Connect any IO and GND pin of the controller to the EN and GND pin of the module respectively. When the IO pin is driven HIGH, the regulated output turns on. When driven LOW, the output turns OFF. This function is extremely useful in low power application. For example, connect all VCC and GND pins of the peripherals (sensors or other modules) to the OUT1 and GND1 pins. Turn on OUT1 and read all the data from the sensors. Turn off OUT1 and put the controller into sleep mode for example 1s until next wake up. By cycling the system into such discontinuous (or pulse) operation pattern, the average power consumption can be greatly reduced. Average power consumption and data acquisition interval are the trade off under such situation.

Attention

Turn off OUT1 5V output will not turn off USB OUT 5V output, which CAN NOT be shutdown. The **total** output power of USB OUT and OUT1 should not exceed $5V \times 1.5A = 7.5W$. When OUT1 and OUT3 are turned ON, the corresponding GND1 and GND3 will be connected to the system ground GND. When they are turned OFF, GND1 and GND3 become floating (disconnected from GND).

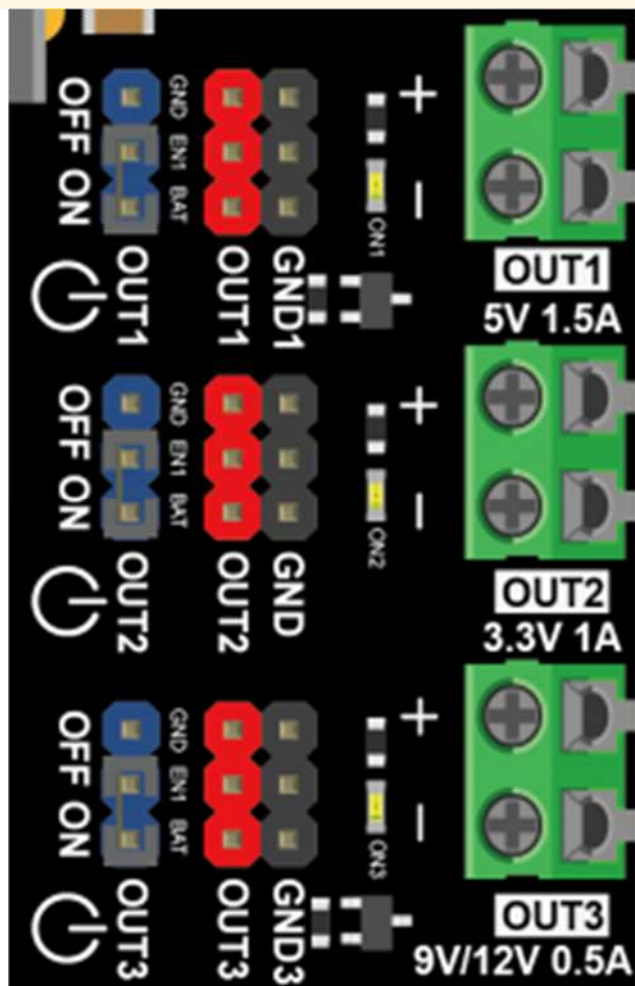

Regulated power supply

LED Indicators

There are three types of LED indicators indicating the operation status of different parts of the module:

Reverse connection LED indicators: when the battery or solar panel are reverse connected at the BAT IN or SOLAR IN, the corresponding orange LEDs **REV BAT** or **REV SOLAR** turn ON, informing the user a reverse connection error.



Charge LED indicators: when using the USB IN to charge the battery, the **CHG USB** LED (red) turns ON. If the battery is fully charged, the **CHG USB** LED turns OFF and the **DONE** LED (green) turn ON. **The DONE is only used to indicate whether the battery is fully charged or not with USB IN and does not apply to SOLAR IN.** If no battery is connected, both LEDs turn ON. When using the SOLAR IN to charge the battery, **CHG SOLAR** (red) turn ON. This LED will be turned off when the battery is fully charge, and flash when no battery is connected to BAT IN. If the sunlight is too weak, the circuit may fail to charge the battery with solar panel. The CHG SOLAR turns OFF. It should be noted that when charging the battery with SOLAR IN and discharging it on regulated output OUT at the same time, CHG SOLAR will be ALWAYS ON, no matter the battery is fully charged or not. Use the analog input to read whether the battery voltage is close to 4.2V to determine whether the battery is fully charged under such situation.



Note: When the MPPT function is turned on or off, the CHG SOLAR solar charge indicator will perform differently.

When the MPPT function is turned on, CHG SOLAR does not light up if the battery charge current is less than 250mA. Although the battery is still being charged with a small current, it means that the solar panel is under weak light, or it is not directly facing the sun.

When the MPPT function is turned off, as long as the open circuit voltage of the solar panel is higher than 7V, the CHG SOLAR will be turned on, irrespective of charge current flowing into the battery.

Regulated output LED indicators: Three LEDs **ON1-ON3** (green) indicate the ON/OFF status of the corresponding regulated output OUT1-OUT3. The **ON** LED turns ON when OUT turns ON and vice versa. Again, the USB OUT can not be shut down and has no LED indicator. Once one of the USB IN, BAT IN and SOLAR IN are available, the USB OUT outputs a 5V.

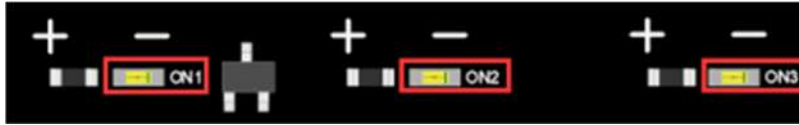

Regulated output LEDs

Cooling Fin installation

If an AC adapter or a 10W (or above) solar panel is used at the SOLAR IN, the solar power management IC LTC3652 may run into full-load. The chip has over-temperature protection function, which will automatically limit the charge current trying to protect the chip. To improve cooling and maximize charge current, which results in longer life-span and better performance, it is highly recommended to stick the **Aluminum cooling fin** with the **blue thermal conductive silica pad** to the bottom of the module, where the label “Cooling Fin” is located.



Cooling fin install location

Protection Functions

Li-battery protection: The module employs a dedicated Li-battery protection chip to improve the life-span and safety of the battery. When the battery voltage exceeds 4.3V, the chip shut down the charge path to prevent it from further being charged (but still allow discharging). When the battery voltage drops below 2.4V, the output of the battery is shut down to prevent it from further being discharged. It is likely to cause permanent damage to the “fragile” battery, if it is extremely over discharge or charge. Most of the battery charger can prevent over charge by internally setting the cut off charge voltage to 4.2V for Li battery, but the over discharge situation can only be guaranteed by the battery protection IC packed inside the battery or on the power management module like this one. It is recommended to charge the battery if the OUT2 output LED ON2 is darkening or the battery voltage dropping close to 3V. When the discharge current of the battery exceeds 3A, the discharge path of the battery is shut down.

Reverse connection protection: On the BAT IN and SOLAR IN, the reverse connection protection circuit prevent the reverse voltage from damaging the module and the corresponding LED will light up to inform the user.

Regulated output protection: When the outputs are accidentally shorted, the battery protection chip will quickly shut down the battery discharge path due to large current inrush. Under such situation, all the regulated outputs are shut down. For the over current protection, different regulated outputs acts differently. For OUT2, when the output current exceed 1.1A, the output will be shut down. For OUT1 and OUT3, when the output current exceed the nominal value, the output will NOT be shut down. However, this will cause the temperature of the chips rise quickly triggering the over-temperature protection insides these chips, which results in limiting the output current protecting the circuit.

Attention

Every time reconnect the battery or the battery protection IC cut off charge/discharge due to protection actions, press the BOOT bottom for once or use the USB IN/SOLAR IN to charge the battery to activate the protection IC.

Application Examples

Use AC adapter to charge Li battery

Utilize the SOLAR IN connector, it is possible to charge the Li battery with common AC adapter within 7V~30V with maximum 2A charge current. Connect the output of the AC adapter (9V or 12V for example) to the DC end of the **Female DC power jack adapter** (included in the kit) and wire the SOLAR IN to the terminal end of the adapter (as shown followed). Switch the last bit (label "OFF" No. 1) to ON and remain the other bits at OFF.

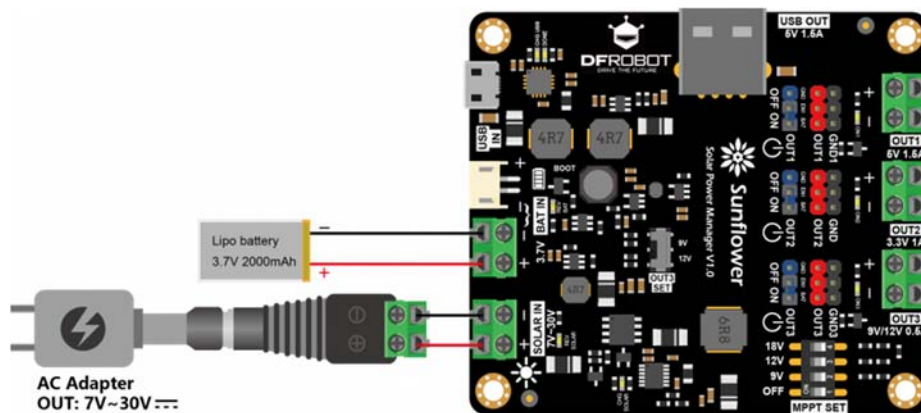

Use AC adapter to charge Li battery

Use the USB to charge battery

Utilize the USB charge function, the user can build a USB/solar power bank for outdoor sport application. Charge the battery with solar panel by daytime and USB at night with cell phone charger (if it is available). User can also charge small charge current, low power devices, such as smart band or Bluetooth headset with the USB OUT.

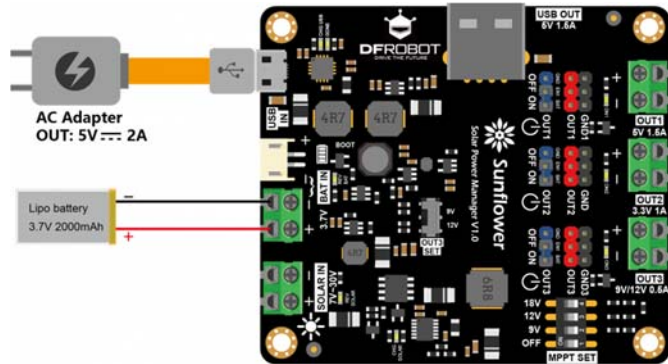

Use USB charger to charge Li battery

Build a low power environment monitor station

This application example use the BME280 environmental sensor to record temperature, humidity and atmospheric pressure, VEML7700 ambient light sensor to record the the ambient illumination, and DS1307 RTC module to record time. Use the analog input A1 to monitor the battery voltage (equivalently the battery capacity). To achieve lower power consumption, use one Arduino digital IO pin to turn ON the OUT1 power supply, read all the data from the sensors and turn them OFF. Cycle this pattern for a proper interval T to reduce the average power consumption. This can completely get rid of the quiescent power of the peripheral modules. Although single peripheral may consume little power, it can be considerable large for a number of them. This module provides users with effective methods to drive the peripheral modules into discontinuous (pulse) mode to achieve low power operation.

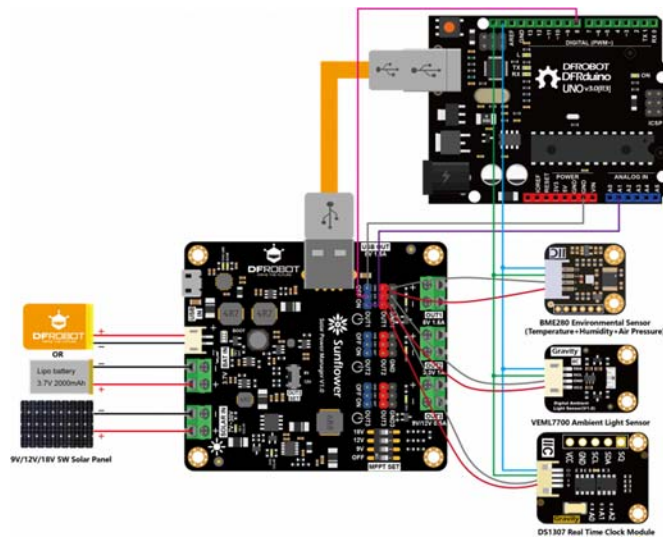

Low power environment monitor sta

https://www.dfrobot.com/wiki/index.php/Sunflower:_Solar_Power_Manager_SKU:_DFR0535 5-25-18