



Chipsmall Limited consists of a professional team with an average of over 10 year of expertise in the distribution of electronic components. Based in Hongkong, we have already established firm and mutual-benefit business relationships with customers from,Europe,America and south Asia,supplying obsolete and hard-to-find components to meet their specific needs.

With the principle of “Quality Parts,Customers Priority,Honest Operation,and Considerate Service”,our business mainly focus on the distribution of electronic components. Line cards we deal with include Microchip,ALPS,ROHM,Xilinx,Pulse,ON,Everlight and Freescale. Main products comprise IC,Modules,Potentiometer,IC Socket,Relay,Connector.Our parts cover such applications as commercial,industrial, and automotives areas.

We are looking forward to setting up business relationship with you and hope to provide you with the best service and solution. Let us make a better world for our industry!



## Contact us

Tel: +86-755-8981 8866 Fax: +86-755-8427 6832

Email & Skype: info@chipsmall.com Web: www.chipsmall.com

Address: A1208, Overseas Decoration Building, #122 Zhenhua RD., Futian, Shenzhen, China





ITEM NO.	NAME	MATERIAL	NOTES
1	HOUSING	PA66	UL94-V0
2	WIRE SCREW	STEEL	M6/ZN PLATED
3	WIRE CONNECTOR	STEEL	M6/ZN PLATED
4	CONDUCTOR	COPPER ALLOY	TIN PLATED
5	MOUNT SCREW	STEEL	M4/ZN PLATED
6	GROUND CLAMP	COPPER ALLOY	TIN PLATED

PART NO.	COLOR	PANTONE #
DG150-YG	YELLOW/GREEN	7404U/362U

REVISIONS					
REV	ZONE	DESCRIPTION	DATE	ECN	BY
A	-	INITIAL RELEASE	09/24/2012	BU-J12374	TJN

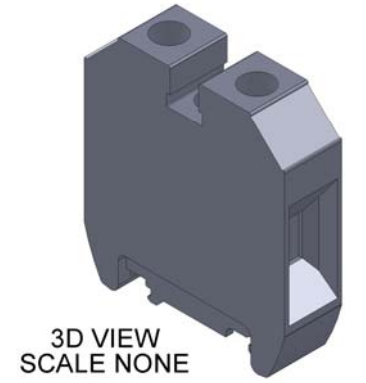
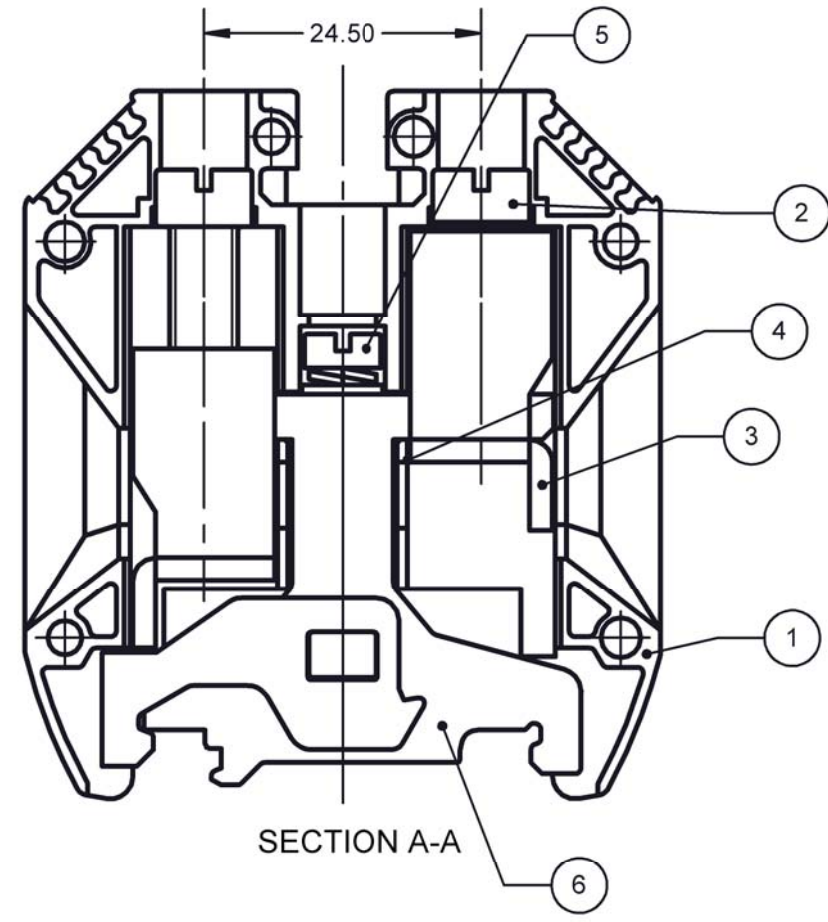
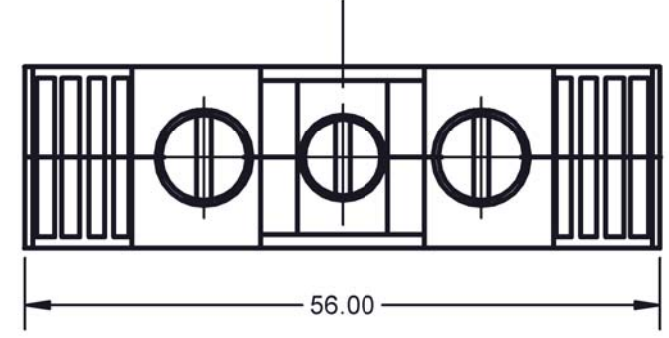
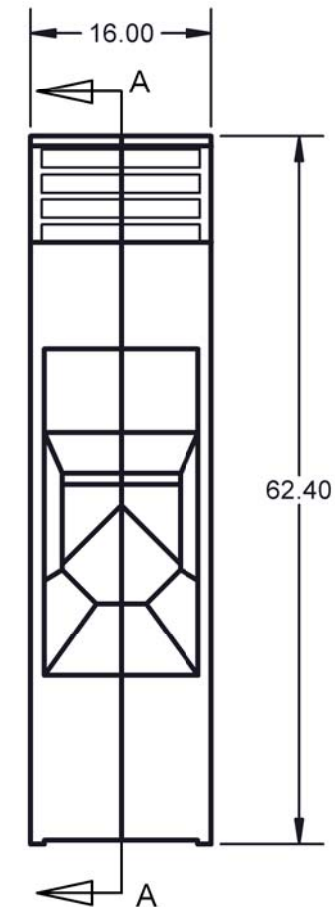
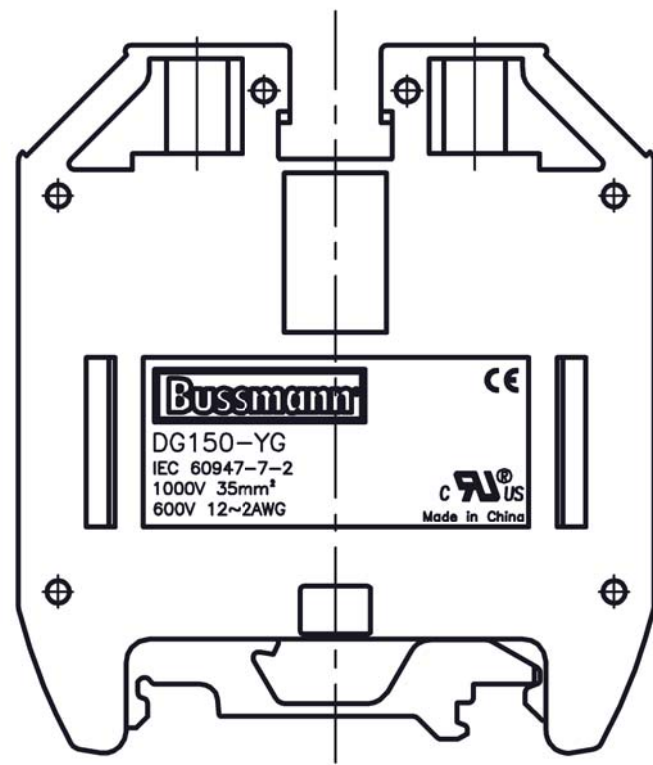

- NOTES:
- RATINGS: UL 600V, IEC 1000V  
INSULATION WITHSTAND VOLTAGE 750VAC/1MINUTE  
TEMPERATURE RANGE -40°C~105°C
  - SEE 2A2943 FOR DIN DIMENSION DETAILS
  - WIRE SCREW TORQUE 5.7N·M (49.4IN·LB)
  - CLAMPING SCREW TORQUE 1.8N·M (15.6IN·LB)
  - WIRE RANGE UL 12~2AWG, IEC 4~35 mm<sup>2</sup>
  - ASSEMBLY MUST BE FREE OF OIL, GREASE AND OTHER FOREIGN MATERIALS.
  - ASSEMBLY MUST COMPLY WITH RoHS SPECIFICATION #1P2163.

MODEL SOURCE DATA	MODEL VERSION	GENERAL DRAWING PRACTICES IN ACCORDANCE WITH ASME - Y14.100-2004 DIMENSIONS AND TOLERANCES IN ACCORDANCE WITH ASME - Y14.5M-1994	APPROVALS	DATE	 <b>COOPER Bussmann</b> St. Louis, MO 63178 (USA)
THIS DRAWING IS AN UNCONTROLLED COPY IF PRINTED OR SENT ELECTRONICALLY. DO NOT SCALE DRAWING		UNLESS OTHERWISE SPECIFIED DIMENSIONS ARE IN MILLIMETERS TOLERANCES TO BE ONE PLACE X.X = ±0.3 mm TWO PLACE X.X X = ±0.13 mm ALL ANGLES X X = ±1°	PROJECT ENGINEER	09/26/2012	
CONFIDENTIAL. THE INFORMATION CONTAINED IN THIS DOCUMENT IS THE PROPERTY OF COOPER INDUSTRIES, INC. IT IS NOT FOR PUBLIC DISCLOSURE. POSSESSION OF THE INFORMATION DOES NOT CONVEY ANY RIGHT TO LOAN, SELL, OR DISCLOSE THE INFORMATION. UNAUTHORIZED REPRODUCTION OR USE OF THE INFORMATION IS PROHIBITED. THIS DOCUMENT IS TO BE RETURNED TO COOPER INDUSTRIES, INC. UPON COMPLETION OF THE PURPOSE FOR WHICH IT WAS LOANED OR UPON REQUEST.			DRAWN	09/26/2012	
COPYRIGHT © COOPER INDUSTRIES, INC. THIS IS AN UNPUBLISHED WORK. THE DISCLOSURE OF THIS WORK IS LIMITED TO SELECT PERSONNEL. FURTHER DISSEMINATION OR DISCLOSURE TO THE PUBLIC IS PROHIBITED. THIS UNPUBLISHED WORK IS PROTECTED BY FEDERAL COPYRIGHT LAW AND ALL RIGHTS THEREUNDER ARE RESERVED BY COOPER INDUSTRIES, INC.		SPECIAL CHARACTERISTIC	SEE TABLE	DATE	
		SIGNIFICANT CHARACTERISTIC	SEE TABLE	REV	
THIRD ANGLE PROJECTION			TITLE		GROUNDING TERMINAL BLOCK
SIZE			DWG NO.		DG150-YG
SCALE: 1.5:1			SHEET		1 OF 1