



Chipsmall Limited consists of a professional team with an average of over 10 year of expertise in the distribution of electronic components. Based in Hongkong, we have already established firm and mutual-benefit business relationships with customers from,Europe,America and south Asia,supplying obsolete and hard-to-find components to meet their specific needs.

With the principle of “Quality Parts,Customers Priority,Honest Operation,and Considerate Service”,our business mainly focus on the distribution of electronic components. Line cards we deal with include Microchip,ALPS,ROHM,Xilinx,Pulse,ON,Everlight and Freescale. Main products comprise IC,Modules,Potentiometer,IC Socket,Relay,Connector.Our parts cover such applications as commercial,industrial, and automotives areas.

We are looking forward to setting up business relationship with you and hope to provide you with the best service and solution. Let us make a better world for our industry!



## Contact us

Tel: +86-755-8981 8866 Fax: +86-755-8427 6832

Email & Skype: info@chipsmall.com Web: www.chipsmall.com

Address: A1208, Overseas Decoration Building, #122 Zhenhua RD., Futian, Shenzhen, China



# Single 16-Channel/Differential 8-Channel, CMOS Analog Multiplexers

## DG406, DG407

The DG406 and DG407 monolithic CMOS analog multiplexers are drop-in replacements for the popular DG506A and DG507A series devices. They each include an array of sixteen analog switches, a TTL and CMOS compatible digital decode circuit for channel selection, a voltage reference for logic thresholds, and an ENABLE input for device selection when several multiplexers are present.

These multiplexers feature lower signal ON-resistance (<math><100\Omega</math>) and faster transition time (

The improvements in the DG406 series are made possible by using a high voltage silicon-gate process. An epitaxial layer prevents the latch-up associated with older CMOS technologies. The 44V maximum voltage range permits controlling 30V<sub>p-p</sub> signals when operating with  $\pm 15\text{V}$  power supplies.

The sixteen switches are bilateral, equally matched for AC or bidirectional signals. The ON-resistance variation with analog signals is quite low over a  $\pm 5\text{V}$  analog input range.

## Features

- ON-Resistance (Max) .....  $100\Omega$
- Low Power Consumption ( $P_D$ ) .....  $<1.2\text{mW}$
- Fast Transition Time (Max) ..... 300ns
- Low Charge Injection
- TTL, CMOS Compatible
- Single or Split Supply Operation
- Pb-Free (RoHS Compliant)

## Applications

- Battery Operated Systems
- Data Acquisition
- Medical Instrumentation
- Hi-Rel Systems
- Communication Systems
- Automatic Test Equipment

## Related Literature

- Technical Brief [TB363](#) "Guidelines for Handling and Processing Moisture Sensitive Surface Mount Devices (SMDs)"

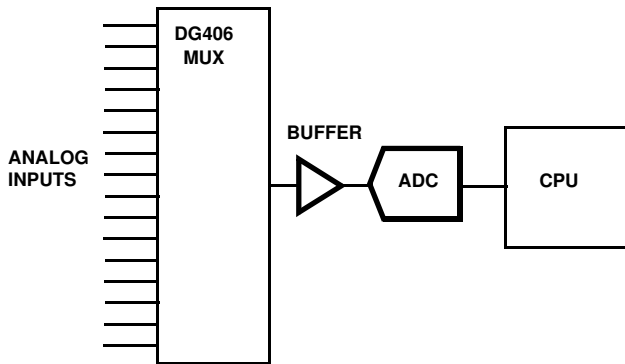

FIGURE 1. TYPICAL APPLICATION

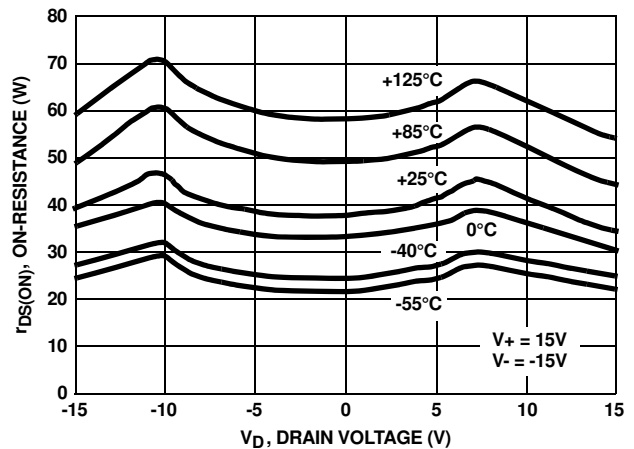
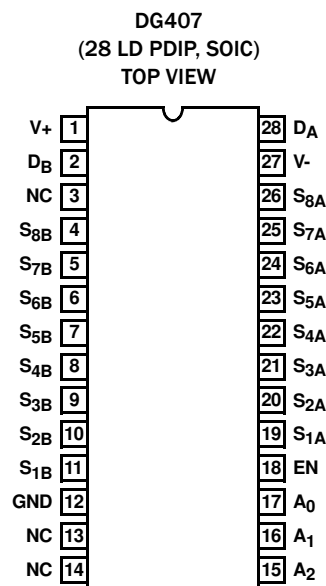
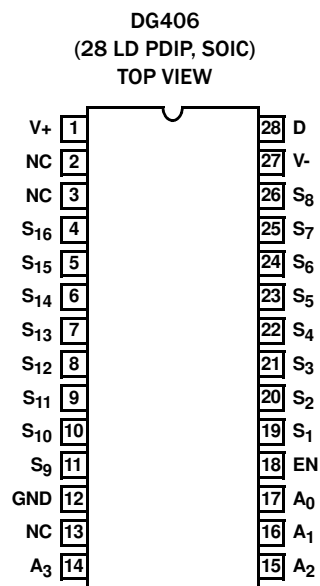

FIGURE 2.  $\pm 15\text{V}$  DUAL SUPPLY  $r_{\text{ON}}$  CURVES AT VARIOUS TEMPERATURES

# DG406, DG407

## Pin Configurations



## Pin Description

DG406 (PDIP, SOIC)	DG407 (PDIP, SOIC)	SYMBOL	DESCRIPTION
1	1	V+	Positive Power Supply
2, 3, 13	3, 13, 14,	NC	No Connect- No Internal Connection
4, 5, 6, 7, 8, 9, 10, 11	-	S <sub>16</sub> thru S <sub>9</sub>	Source Switch Terminals (These pins can be an input or output)
12	12	GND	Ground (0V) Reference
14, 15, 16, 17	-	A <sub>3</sub> thru A <sub>0</sub>	Logic Control Inputs
-	15, 16, 17	A <sub>2</sub> thru A <sub>0</sub>	Logic Control Inputs
18	18	EN	Active High Digital Input (When low device is disabled and all switches are turned off. When high the A <sub>x</sub> logic inputs determine which switch is turned on.
19, 20, 21, 22, 23, 24, 25, 26	-	S <sub>1</sub> thru S <sub>8</sub>	Source Switch Terminals (These pins can be an input or output)
27	27	V-	Negative Power Supply (Single supply application this pin will be connected to ground.)
28	-	D	Drain Switch Terminal (This pin can be an input or output)
-	2, 28	D <sub>B</sub> , D <sub>A</sub>	Drain Switch Terminal (This pin can be an input or output)
-	4, 5, 6, 7, 8, 9, 10, 11	S <sub>1B</sub> thru S <sub>8B</sub>	Source Switch Terminals B (These pins can be an input or output)
-	19, 20, 21, 22, 23, 24, 25, 26	S <sub>1A</sub> thru S <sub>8A</sub>	Source Switch Terminals A (These pins can be an input or output)

## Ordering Information

PART NUMBER (Notes 2, 4)	PART MARKING	TEMP. RANGE (°C)	PACKAGE (Pb-free)	PKG. DWG. #
DG406DJZ	DG406DJZ	-40 to +85	28 Ld PDIP (Note 3)	E28.6
DG406DYZ	DG406DYZ	-40 to +85	28 Ld SOIC	M28.3
DG406DYZ-T (Note 1)	DG406DYZ	-40 to +85	28 Ld SOIC Tape and Reel	M28.3
DG407DJZ	DG407DJZ	-40 to +85	28 Ld PDIP (Note 3)	E28.6
DG407DYZ	DG407DYZ	-40 to +85	28 Ld SOIC	M28.3
DG407DYZ-T (Note 1)	DG407DYZ	-40 to +85	28 Ld SOIC Tape and Reel	M28.3

### NOTES:

1. Please refer to [TB347](#) for details on reel specifications.
2. These Intersil Pb-free plastic packaged products employ special Pb-free material sets, molding compounds/die attach materials, and 100% matte tin plate plus anneal (e3 termination finish, which is RoHS compliant and compatible with both SnPb and Pb-free soldering operations). Intersil Pb-free products are MSL classified at Pb-free peak reflow temperatures that meet or exceed the Pb-free requirements of IPC/JEDEC J STD-020.
3. Pb-free PDIPs can be used for through-hole wave solder processing only. They are not intended for use in Reflow solder processing applications.
4. For Moisture Sensitivity Level (MSL), please see device information page for [DG406, DG407](#). For more information on MSL, please see tech brief [TB363](#)

## Schematic Diagram (Typical Channel)

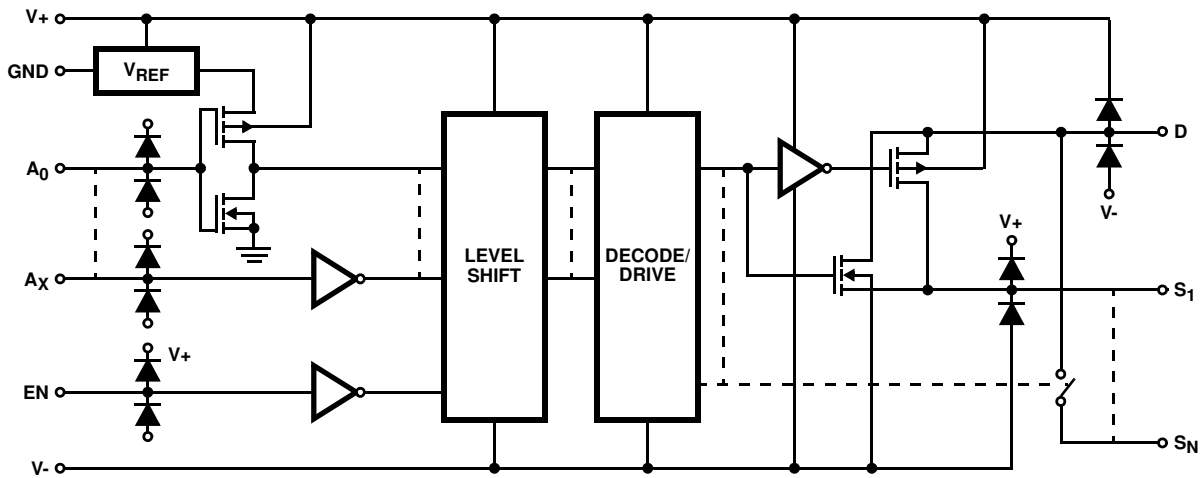

## Functional Diagrams

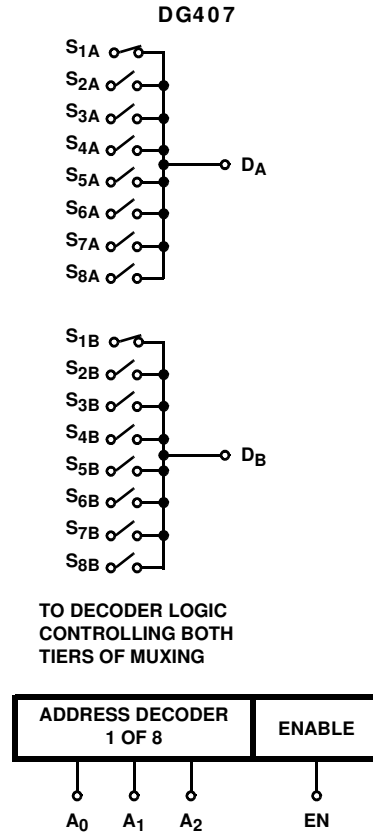
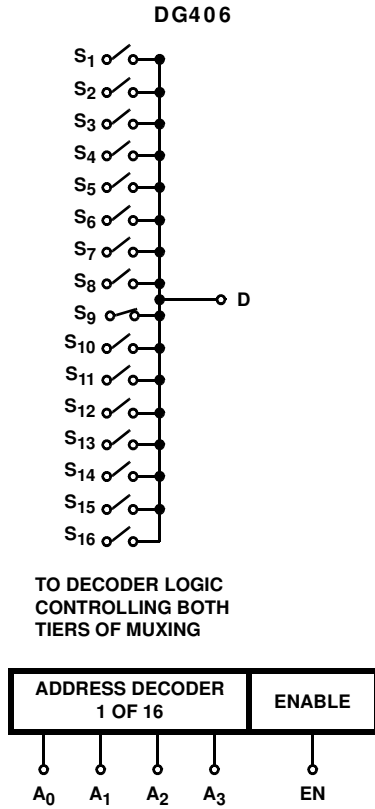

## Truth Tables

TABLE 1. DG406 TRUTH TABLE

A <sub>3</sub>	A <sub>2</sub>	A <sub>1</sub>	A <sub>0</sub>	EN	ON SWITCH
X	X	X	X	0	None
0	0	0	0	1	1
0	0	0	1	1	2
0	0	1	0	1	3
0	0	1	1	1	4
0	1	0	0	1	5
0	1	0	1	1	6
0	1	1	0	1	7
0	1	1	1	1	8
1	0	0	0	1	9
1	0	0	1	1	10
1	0	1	0	1	11
1	0	1	1	1	12
1	1	0	0	1	13
1	1	0	1	1	14
1	1	1	0	1	15
1	1	1	1	1	16

TABLE 2. DG407 TRUTH TABLE

A <sub>2</sub>	A <sub>1</sub>	A <sub>0</sub>	EN	ON SWITCH PAIR
X	X	X	0	None
0	0	0	1	1A, 1B
0	0	1	1	2A, 2B
0	1	0	1	3A, 3B
0	1	1	1	4A, 4B
1	0	0	1	5A, 5B
1	0	1	1	6A, 6B
1	1	0	1	7A, 7B
1	1	1	1	8A, 8B

Logic "0" = V<sub>AL</sub> < 0.8V.  
 Logic "1" = V<sub>AH</sub> > 2.4V.  
 X = Don't Care.

# DG406, DG407

## Absolute Maximum Ratings

V+ to V- .....	44.0V
GND to V- .....	25V
Digital Inputs, V <sub>S</sub> , V <sub>D</sub> (Note 6) .....(V-) -2V to (V+) +2V or 20mA, Whichever Occurs First	
Continuous Current (Any Terminal) .....	30mA
Peak Current, S or D (Pulsed 1ms, 10% Duty Cycle Max) .....	100mA

## Thermal Information

Thermal Resistance (Typical, Note 5)	$\theta_{JA}$ (°C/W)
PDIP Package* .....	60
SOIC Package .....	75
Maximum Junction Temperature .....	+150°C
Maximum Storage Temperature Range .....	-65°C to +150°C
Pb-Free Reflow Profile .....	see link below <a href="http://www.intersil.com/pbfree/Pb-FreeReflow.asp">http://www.intersil.com/pbfree/Pb-FreeReflow.asp</a>
*Pb-free PDIPs can be used for through-hole wave solder processing only. They are not intended for use in Reflow solder processing applications.	

## Operating Conditions

Temperature Range .....	-40°C to +85°C
-------------------------	----------------

CAUTION: Do not operate at or near the maximum ratings listed for extended periods of time. Exposure to such conditions may adversely impact product reliability and result in failures not covered by warranty.

### NOTES:

- $\theta_{JA}$  is measured with the component mounted on a low effective thermal conductivity test board in free air. See Tech Brief TB379 for details.
- Signals on S<sub>X</sub>, D<sub>X</sub>, EN or A<sub>X</sub> exceeding V+ or V- are clamped by internal diodes. Limit diode current to maximum current ratings.

**Electrical Specifications** Test Conditions: V+ = +15V, V- = -15V, V<sub>AL</sub> = 0.8V, V<sub>AH</sub> = 2.4V Unless Otherwise Specified. **Bold-face limits apply over the operating temperature range, -40°C to +85°C.**

PARAMETER	TEST CONDITIONS	TEMP (°C)	MIN (Notes 7, 12)	TYP (Note 8)	MAX (Notes 7, 12)	UNITS	
<b>DYNAMIC CHARACTERISTICS</b>							
Transition Time, t <sub>TRANS</sub>	(See Figure 3)	25	-	200	300	ns	
		Full	-	-	<b>400</b>	ns	
Break-Before-Make Interval, t <sub>OPEN</sub>	(See Figure 5)	25	25	50	-	ns	
		Full	<b>10</b>	-	-	ns	
Enable Turn-ON Time, t <sub>ON(EN)</sub>	(See Figure 4)	25	-	150	200	ns	
		Full	-	-	<b>400</b>	ns	
Enable Turn-OFF Time, t <sub>OFF(EN)</sub>		25	-	70	150	ns	
		Full	-	-	<b>300</b>	ns	
Charge Injection, Q	C <sub>L</sub> = 1nF, V <sub>S</sub> = 0V, R <sub>S</sub> = 0Ω	25	-	40	-	pC	
OFF-Isolation, OIRR	V <sub>EN</sub> = 0V, R <sub>L</sub> = 1kΩ, f = 100kHz (Note 11)	25	-	-69	-	dB	
Logic Input Capacitance, C <sub>IN</sub>	f = 1MHz	25	-	7	-	pF	
Source OFF Capacitance, C <sub>S(OFF)</sub>	V <sub>EN</sub> = 0V, V <sub>S</sub> = 0V, f = 1MHz	25	-	8	-	pF	
Drain OFF Capacitance, C <sub>D(OFF)</sub>	V <sub>EN</sub> = 0V, V <sub>D</sub> = 0V, f = 1MHz	DG406	25	-	160	-	pF
		DG407	25	-	80	-	pF
Drain ON Capacitance, C <sub>D(ON)</sub>	V <sub>EN</sub> = 5V, V <sub>D</sub> = 0V, f = 1MHz	DG406	25	-	180	-	pF
		DG407	25	-	90	-	pF
<b>DIGITAL INPUT CHARACTERISTICS</b>							
Logic High Input Voltage, V <sub>INH</sub>		Full	<b>2.4</b>	-	-	V	
Logic Low Input Voltage, V <sub>INL</sub>		Full	-	-	<b>0.8</b>	V	
Logic High Input Current, I <sub>AH</sub>	V <sub>A</sub> = 2.4V, 15V	Full	<b>-1</b>	-	<b>1</b>	μA	
Logic Low Input Current, I <sub>AL</sub>	V <sub>EN</sub> = 0V, 2.4V, V <sub>A</sub> = 0V	Full	<b>-1</b>	-	<b>1</b>	μA	
<b>ANALOG SWITCH CHARACTERISTICS</b>							
Drain-Source ON-Resistance, r <sub>DS(ON)</sub>	V <sub>D</sub> = ±10V, I <sub>S</sub> = +10mA (Note 9)	25	-	50	100	Ω	
		Full	-	-	<b>125</b>	Ω	
r <sub>DS(ON)</sub> Matching Between Channels, Δr <sub>DS(ON)</sub>	V <sub>D</sub> = 10V, -10V (Note 10)	25	-	5	-	%	

# DG406, DG407

**Electrical Specifications** Test Conditions:  $V_+ = +15V$ ,  $V_- = -15V$ ,  $V_{AL} = 0.8V$ ,  $V_{AH} = 2.4V$  Unless Otherwise Specified. **Bold-face limits apply over the operating temperature range,  $-40^\circ C$  to  $+85^\circ C$ . (Continued)**

PARAMETER	TEST CONDITIONS	TEMP ( $^\circ C$ )	MIN (Notes 7, 12)	TYP (Note 8)	MAX (Notes 7, 12)	UNITS
Source OFF Leakage Current, $I_{S(OFF)}$	$V_{EN} = 0V$ , $V_S = \pm 10V$ , $V_D = \mp 10V$	25	-0.5	0.01	0.5	nA
		Full	<b>-5</b>	-	<b>5</b>	nA
Drain OFF Leakage Current, $I_{D(OFF)}$ DG406		25	-1	0.04	1	nA
		Full	<b>-40</b>	-	<b>40</b>	nA
DG407	25	-1	0.04	1	nA	
	Full	<b>-20</b>	-	<b>20</b>	nA	
Drain ON Leakage Current, $I_{D(ON)}$ DG406	$V_S = V_D = \pm 10V$ (Note 9)	25	-1	0.04	1	nA
		Full	<b>-40</b>	-	<b>40</b>	nA
DG407		25	-1	0.04	1	nA
		Full	<b>-20</b>	-	<b>20</b>	nA
<b>POWER SUPPLY CHARACTERISTICS</b>						
Positive Supply Current, I+	$V_{EN} = V_A = 0V$ or 5V (Standby)	25	-	13	30	$\mu A$
		Full	-	-	<b>75</b>	$\mu A$
Negative Supply Current, I-		25	-1	-0.01	-	$\mu A$
		Full	<b>-10</b>	-	-	$\mu A$
Positive Supply Current, I+	$V_{EN} = 2.4V$ , $V_A = 0V$ (Enabled)	25	-	80	100	$\mu A$
		Full	-	-	<b>200</b>	$\mu A$
Negative Supply Current, I-		25	-1	-0.01	-	$\mu A$
		Full	<b>-10</b>	-	-	$\mu A$

**Electrical Specifications** MSingle Supply Test Conditions:  $V_+ = 12V$ ,  $V_- = 0V$ ,  $V_{AL} = 0.8V$ ,  $V_{AH} = 2.4V$ , Unless Otherwise Specified.

PARAMETER	TEST CONDITIONS	TEMP ( $^\circ C$ )	MIN (Notes 7, 12)	TYP (Note 8)	MAX (Notes 7, 12)	UNITS
<b>DYNAMIC CHARACTERISTICS</b>						
Switching Time of Multiplexer, $t_{TRANS}$	$V_{S1} = 8V$ , $V_{S8} = 0V$ , $V_{IN} = 2.4V$	25	-	300	450	ns
Enable Turn-ON Time, $t_{ON(EN)}$	$V_{INH} = 2.4V$ , $V_{INL} = 0V$ , $V_{S1} = 5V$	25	-	250	600	ns
Enable Turn-OFF Time, $t_{OFF(EN)}$		25	-	150	300	ns
Charge Injection, Q	$C_L = 1nF$ , $V_S = 6V$ , $R_S = 0\Omega$	25	-	20	-	pC
<b>ANALOG SWITCH CHARACTERISTICS</b>						
Analog Signal Range, $V_{ANALOG}$		Full	<b>0</b>	-	<b>12</b>	V
Drain-Source ON-Resistance, $r_{DS(ON)}$	$V_D = 3V$ , $10V$ , $I_S = -1mA$ (Note 9)	25	-	90	120	$\Omega$
$r_{DS(ON)}$ Matching Between Channels (Note 6), $\Delta r_{DS(ON)}$		25	-	5	-	%
Source Off Leakage Current, $I_{S(OFF)}$	$V_{EN} = 0V$ , $V_D = 10V$ or $0.5V$ , $V_S = 0.5V$ or $10V$	25	-	0.01	-	nA
Drain Off Leakage Current, $I_{D(OFF)}$ DG406		25	-	0.04	-	nA
DG407		25	-	0.04	-	nA

# DG406, DG407

**Electrical Specifications** Single Supply Test Conditions:  $V_+ = 12V$ ,  $V_- = 0V$ ,  $V_{AL} = 0.8V$ ,  $V_{AH} = 2.4V$ ,  
Unless Otherwise Specified. (Continued)

PARAMETER	TEST CONDITIONS	TEMP (°C)	MIN (Notes 7, 12)	TYP (Note 8)	MAX (Notes 7, 12)	UNITS
Drain On Leakage Current, $I_{D(ON)}$	$V_S = V_D = \pm 10V$ (Note 9)	25	-	0.04	-	nA
		25	-	0.04	-	nA
<b>POWER SUPPLY CHARACTERISTICS</b>						
Positive Supply Current ( $I_+$ ) (Standby)	$V_{EN} = 0V$ or $5V$ , $V_A = 0V$ or $5V$	25	-	13	30	$\mu A$
		Full	-	13	75	$\mu A$
Negative Supply Current ( $I_-$ ) (Enabled)		25	-1	-0.01	-	$\mu A$
		Full	-5	-0.01	-	$\mu A$

**NOTES:**

- The algebraic convention whereby the most negative value is a minimum and the most positive a maximum, is used in this data sheet.
- Typical values are for design only and are not production tested.
- Sequence each switch ON.
- $\Delta r_{DS(ON)} = (r_{DS(ON)}(Max) - r_{DS(ON)}(Min)) \div r_{DS(ON)} \text{ average}$ .
- Worst case isolation occurs on channel 8B due to proximity to the drain pin.
- Parameters with MIN and/or MAX limits are 100% tested at +25°C, unless otherwise specified. Temperature limits established by characterization and are not production tested.

## Test Circuits and Waveforms

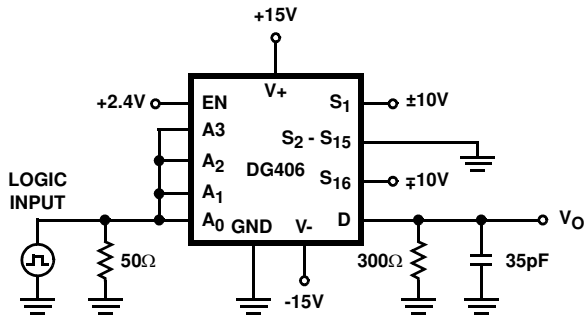

FIGURE 3A. DG406 TEST CIRCUIT

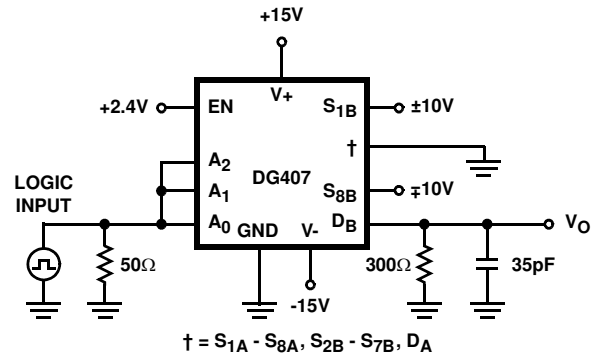

FIGURE 3B. DG407 TEST CIRCUIT

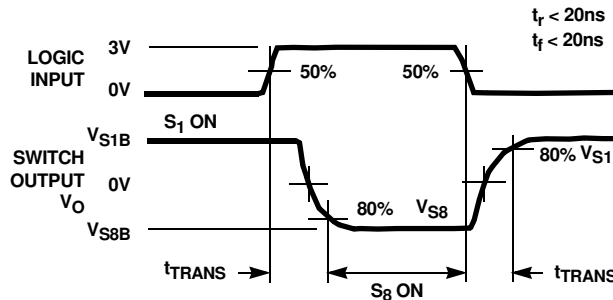

FIGURE 3C. MEASUREMENT POINTS  
FIGURE 3. TRANSITION TIME

## Test Circuits and Waveforms (Continued)

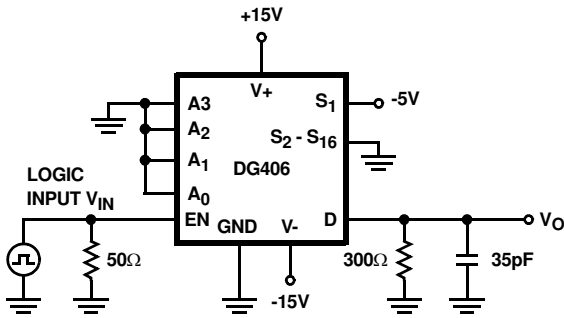

FIGURE 4A. DG406 TEST CIRCUIT

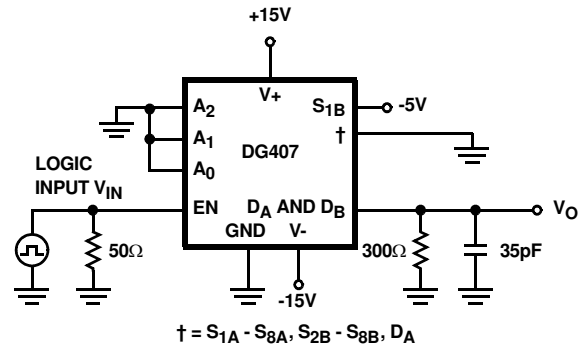

FIGURE 4B. DG407 TEST CIRCUIT

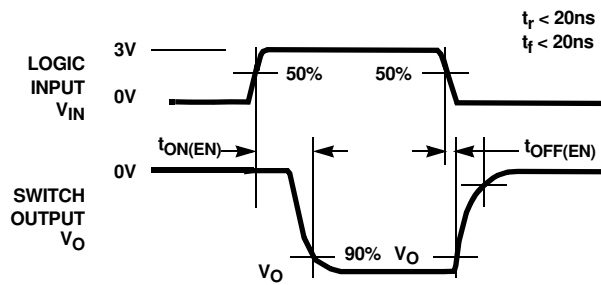

FIGURE 4C. MEASUREMENT POINTS  
FIGURE 4. ENABLE SWITCHING TIMES

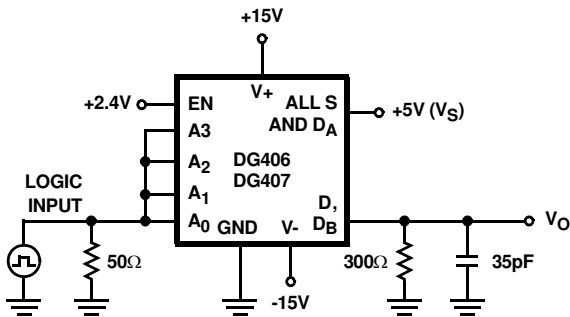

FIGURE 5A. TEST CIRCUIT

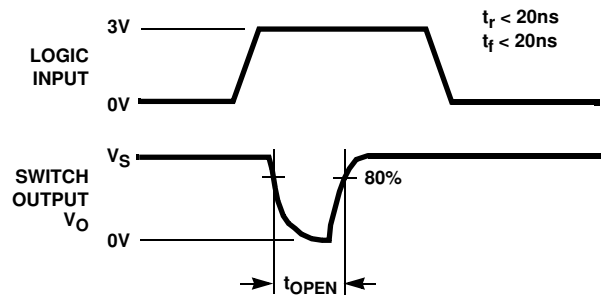

FIGURE 5B. MEASUREMENT POINTS

FIGURE 5. BREAK-BEFORE-MAKE INTERVAL

Typical Performance Curves

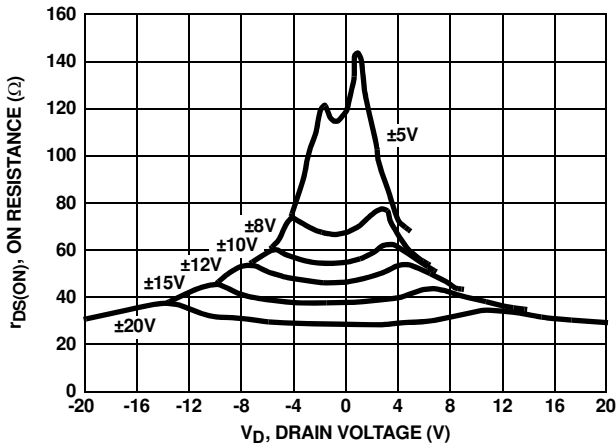

FIGURE 6.  $r_{DS(ON)}$  vs  $V_D$  AND SUPPLY

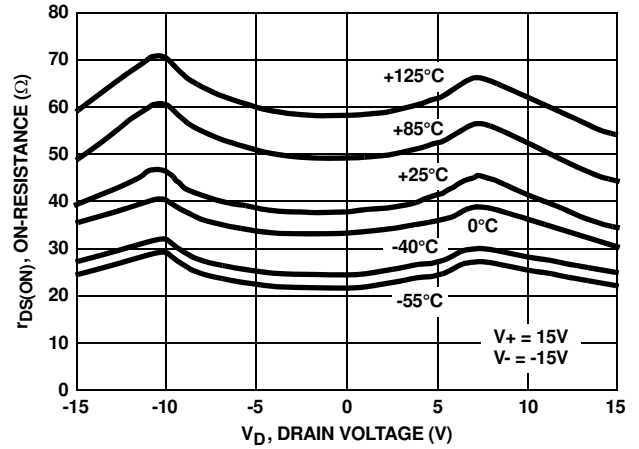

FIGURE 7.  $r_{DS(ON)}$  vs  $V_D$  AND TEMPERATURE

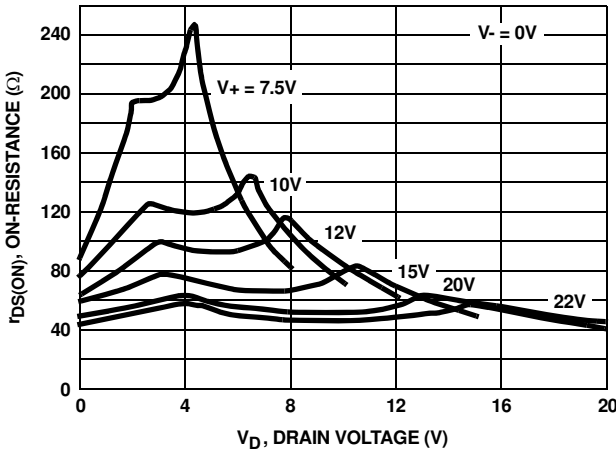

FIGURE 8.  $r_{DS(ON)}$  vs  $V_D$  AND SUPPLY

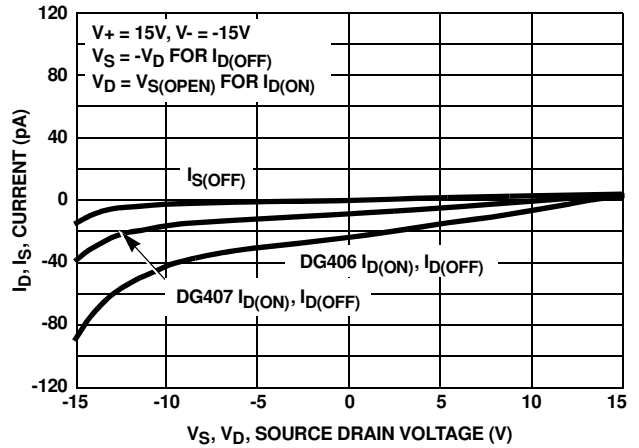

FIGURE 9.  $I_D$ ,  $I_S$  LEAKAGE CURRENTS vs ANALOG VOLTAGE

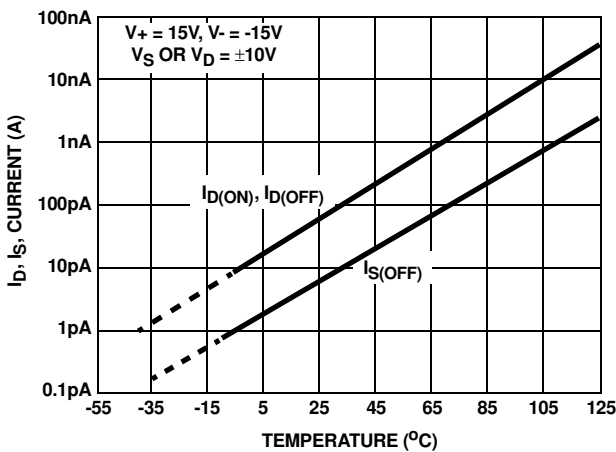

FIGURE 10.  $I_D$ ,  $I_S$  LEAKAGE vs TEMPERATURE

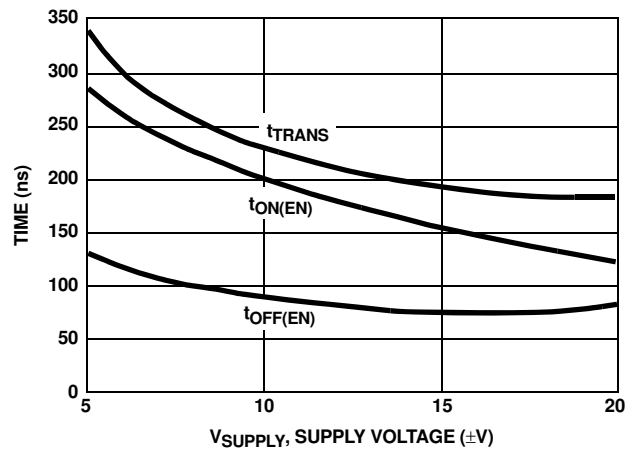

FIGURE 11. SWITCHING TIMES vs BIPOLAR SUPPLIES

## Typical Performance Curves (Continued)

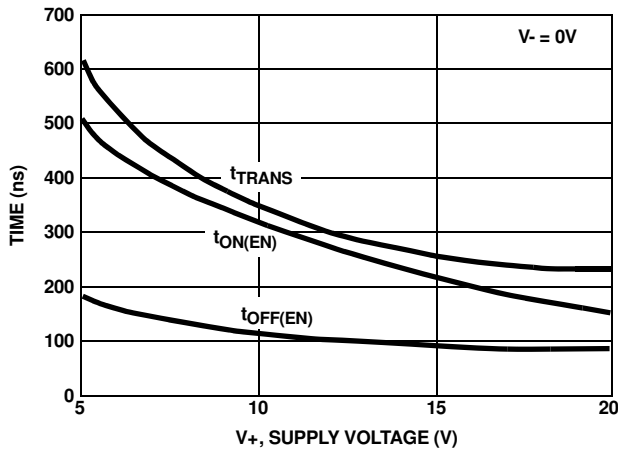

FIGURE 12. SWITCHING TIMES vs SINGLE SUPPLY

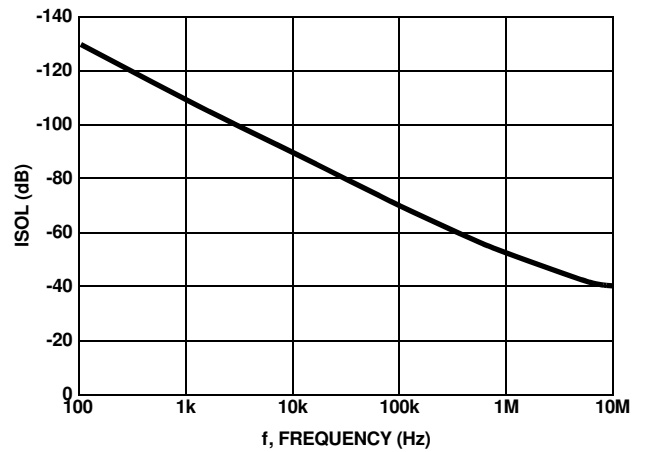

FIGURE 13. OFF-ISOLATION vs FREQUENCY

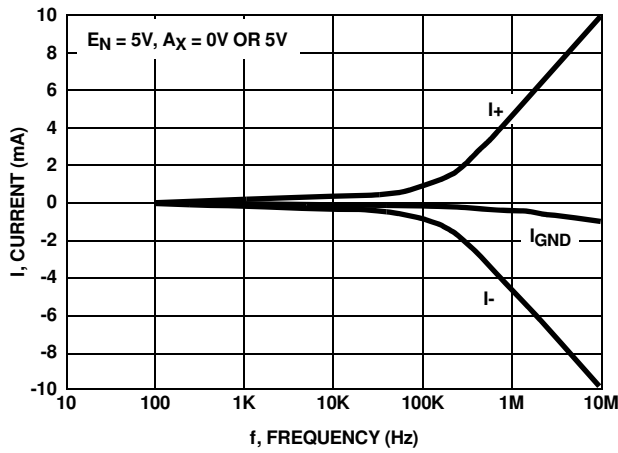

FIGURE 14. SUPPLY CURRENTS vs SWITCHING FREQUENCY

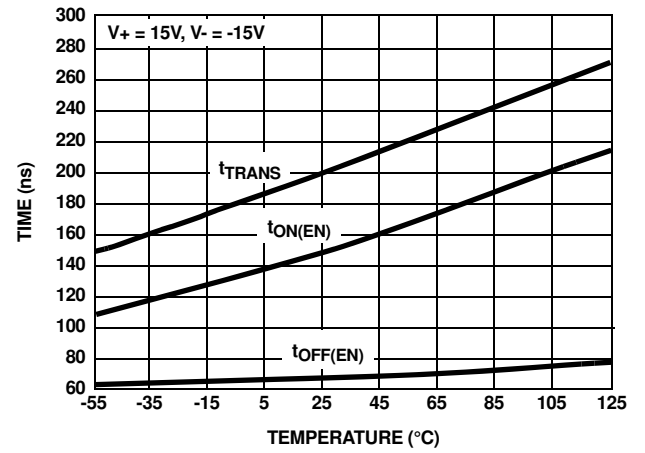

FIGURE 15.  $t_{ON}/t_{OFF}$  vs TEMPERATURE

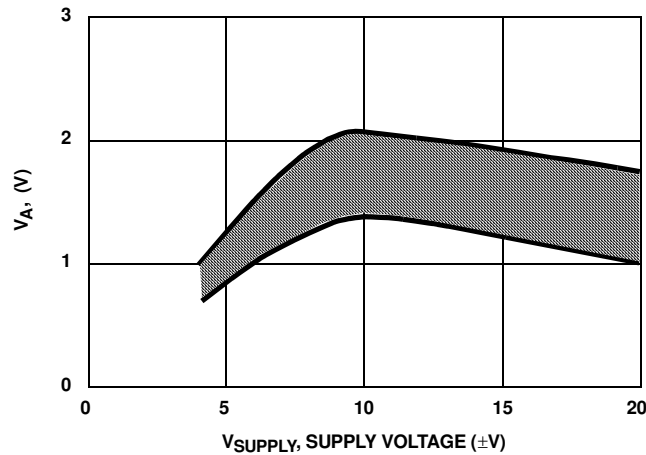

FIGURE 16. SWITCHING THRESHOLD vs SUPPLY VOLTAGE

# DG406, DG407

## Die Characteristics

### DIE DIMENSIONS:

2490 $\mu$ m x 4560 $\mu$ m x 485 $\mu$ m

### METALLIZATION:

Type: SiAl

Thickness: 12k $\text{\AA}$   $\pm$  1k $\text{\AA}$

### PASSIVATION:

Type: Nitride

Thickness: 8k $\text{\AA}$   $\pm$  1k $\text{\AA}$

### WORST CASE CURRENT DENSITY:

$9.1 \times 10^4$  A/cm<sup>2</sup>

## Metallization Mask Layout

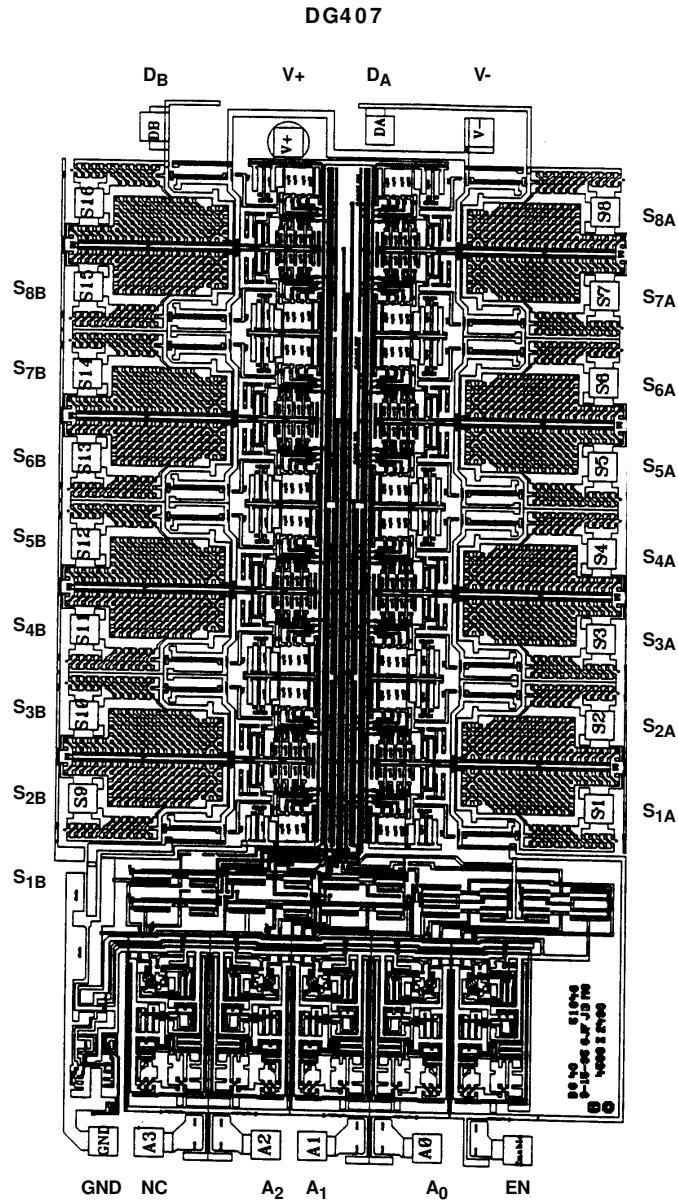

# DG406, DG407

## Die Characteristics

### DIE DIMENSIONS:

2490 $\mu$ m x 4560 $\mu$ m x 485 $\mu$ m

### METALLIZATION:

Type: SiAl

Thickness: 12k $\text{\AA}$   $\pm$  1k $\text{\AA}$

### PASSIVATION:

Type: Nitride

Thickness: 8k $\text{\AA}$   $\pm$  1k $\text{\AA}$

### WORST CASE CURRENT DENSITY:

$9.1 \times 10^4$  A/cm<sup>2</sup>

## Metallization Mask Layout

DG406

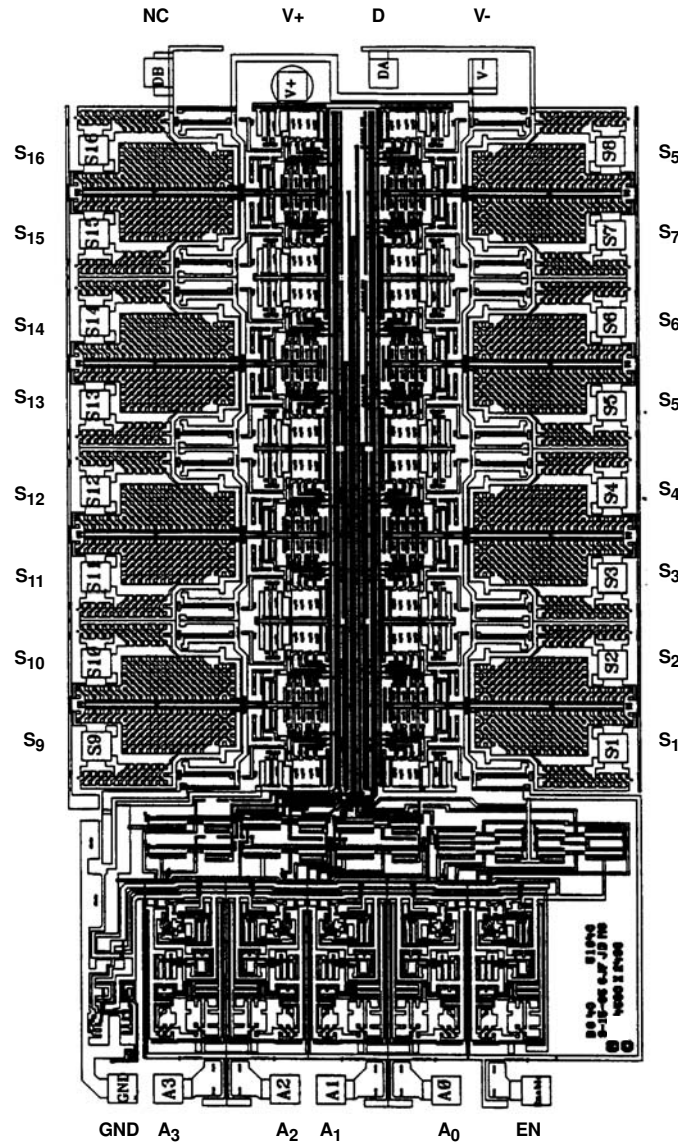

# DG406, DG407

## Revision History

The revision history provided is for informational purposes only and is believed to be accurate, but not warranted. Please go to web to make sure you have the latest Rev.

DATE	REVISION	CHANGE
October 1, 2013	FN3116.11	Converted to new Intersil template. Removed obsolete parts from ordering information as follows: DG406DJ DG406DY DG406DY-T DG407DY DG407DJ Added P/N DG407DYZ-T to Ordering Information table.
March 13, 2006	FN3116.9	Redline Release parts added to ordering information.
September 17, 2004	FN3116.8	Pb-free parts added.
August 1, 2000	FN3116.6	Initial Release to web.

## About Intersil

Intersil Corporation is a leader in the design and manufacture of high-performance analog, mixed-signal and power management semiconductors. The company's products address some of the largest markets within the industrial and infrastructure, personal computing and high-end consumer markets. For more information about Intersil, visit our website at [www.intersil.com](http://www.intersil.com).

For the most updated datasheet, application notes, related documentation and related parts, please see the respective product information page found at [www.intersil.com](http://www.intersil.com). You may report errors or suggestions for improving this datasheet by visiting [www.intersil.com/en/support/ask-an-expert.html](http://www.intersil.com/en/support/ask-an-expert.html). Reliability reports are also available from our website at <http://www.intersil.com/en/support/qualandreliability.html#reliability>

# DG406, DG407

## Dual-In-Line Plastic Packages (PDIP)

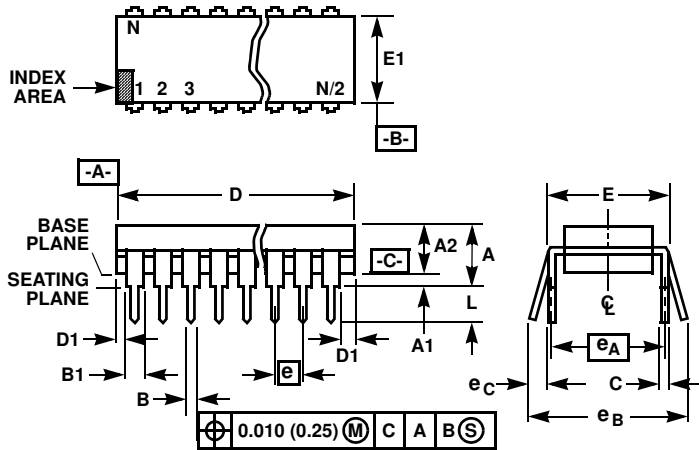

### NOTES:

- Controlling Dimensions: INCH. In case of conflict between English and Metric dimensions, the inch dimensions control.
- Dimensioning and tolerancing per ANSI Y14.5M-1982.
- Symbols are defined in the "MO Series Symbol List" in Section 2.2 of Publication No. 95.
- Dimensions A, A1 and L are measured with the package seated in JEDEC seating plane gauge GS-3.
- D, D1, and E1 dimensions do not include mold flash or protrusions. Mold flash or protrusions shall not exceed 0.010 inch (0.25mm).
- E and  $e_A$  are measured with the leads constrained to be perpendicular to datum  $-C-$ .
- $e_B$  and  $e_C$  are measured at the lead tips with the leads unconstrained.  $e_C$  must be zero or greater.
- B1 maximum dimensions do not include dambar protrusions. Dambar protrusions shall not exceed 0.010 inch (0.25mm).
- N is the maximum number of terminal positions.
- Corner leads (1, N, N/2 and N/2 + 1) for E8.3, E16.3, E18.3, E28.3, E42.6 will have a B1 dimension of 0.030 - 0.045 inch (0.76 - 1.14mm).

### E28.6 (JEDEC MS-011-AB ISSUE B) 28 LEAD DUAL-IN-LINE PLASTIC PACKAGE

SYMBOL	INCHES		MILLIMETERS		NOTES
	MIN	MAX	MIN	MAX	
A	-	0.250	-	6.35	4
A1	0.015	-	0.39	-	4
A2	0.125	0.195	3.18	4.95	-
B	0.014	0.022	0.356	0.558	-
B1	0.030	0.070	0.77	1.77	8
C	0.008	0.015	0.204	0.381	-
D	1.380	1.565	35.1	39.7	5
D1	0.005	-	0.13	-	5
E	0.600	0.625	15.24	15.87	6
E1	0.485	0.580	12.32	14.73	5
e	0.100 BSC		2.54 BSC		-
$e_A$	0.600 BSC		15.24 BSC		6
$e_B$	-	0.700	-	17.78	7
L	0.115	0.200	2.93	5.08	4
N	28		28		9

Rev. 1 12/00

# DG406, DG407

## Small Outline Plastic Packages (SOIC)

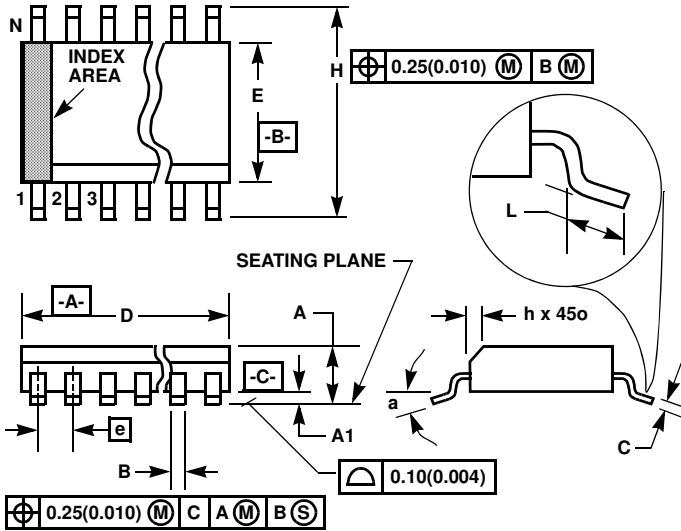

### M28.3 (JEDEC MS-013-AE ISSUE C) 28 LEAD WIDE BODY SMALL OUTLINE PLASTIC PACKAGE

SYMBOL	INCHES		MILLIMETERS		NOTES
	MIN	MAX	MIN	MAX	
A	0.0926	0.1043	2.35	2.65	-
A1	0.0040	0.0118	0.10	0.30	-
B	0.013	0.0200	0.33	0.51	9
C	0.0091	0.0125	0.23	0.32	-
D	0.6969	0.7125	17.70	18.10	3
E	0.2914	0.2992	7.40	7.60	4
e	0.05 BSC		1.27 BSC		-
H	0.394	0.419	10.00	10.65	-
h	0.01	0.029	0.25	0.75	5
L	0.016	0.050	0.40	1.27	6
N	28		28		7
$\alpha$	0°	8°	0°	8°	-

Rev. 1, 1/13

#### NOTES:

- Symbols are defined in the "MO Series Symbol List" in Section 2.2 of Publication Number 95.
- Dimensioning and tolerancing per ANSI Y14.5M-1982.
- Dimension "D" does not include mold flash, protrusions or gate burrs. Mold flash, protrusion and gate burrs shall not exceed 0.15mm (0.006 inch) per side.
- Dimension "E" does not include interlead flash or protrusions. Interlead flash and protrusions shall not exceed 0.25mm (0.010 inch) per side.
- The chamfer on the body is optional. If it is not present, a visual index feature must be located within the crosshatched area.
- "L" is the length of terminal for soldering to a substrate.
- "N" is the number of terminal positions.
- Terminal numbers are shown for reference only.
- The lead width "B", as measured 0.36mm (0.014 inch) or greater above the seating plane, shall not exceed a maximum value of 0.61mm (0.024 inch)
- Controlling dimension: MILLIMETER. Converted inch dimensions are not necessarily exact.

#### TYPICAL RECOMMENDED LAND PATTERN

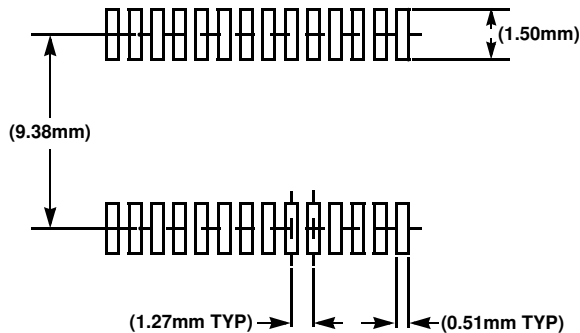

For additional products, see [www.intersil.com/en/products.html](http://www.intersil.com/en/products.html)

Intersil products are manufactured, assembled and tested utilizing ISO9000 quality systems as noted in the quality certifications found at [www.intersil.com/en/support/qualandreliability.html](http://www.intersil.com/en/support/qualandreliability.html)

Intersil products are sold by description only. Intersil Corporation reserves the right to make changes in circuit design, software and/or specifications at any time without notice. Accordingly, the reader is cautioned to verify that data sheets are current before placing orders. Information furnished by Intersil is believed to be accurate and reliable. However, no responsibility is assumed by Intersil or its subsidiaries for its use; nor for any infringements of patents or other rights of third parties which may result from its use. No license is granted by implication or otherwise under any patent or patent rights of Intersil or its subsidiaries.

For information regarding Intersil Corporation and its products, see [www.intersil.com](http://www.intersil.com)