



Chipsmall Limited consists of a professional team with an average of over 10 year of expertise in the distribution of electronic components. Based in Hongkong, we have already established firm and mutual-benefit business relationships with customers from,Europe,America and south Asia,supplying obsolete and hard-to-find components to meet their specific needs.

With the principle of “Quality Parts,Customers Priority,Honest Operation,and Considerate Service”,our business mainly focus on the distribution of electronic components. Line cards we deal with include Microchip,ALPS,ROHM,Xilinx,Pulse,ON,Everlight and Freescale. Main products comprise IC,Modules,Potentiometer,IC Socket,Relay,Connector.Our parts cover such applications as commercial,industrial, and automotives areas.

We are looking forward to setting up business relationship with you and hope to provide you with the best service and solution. Let us make a better world for our industry!



## Contact us

Tel: +86-755-8981 8866 Fax: +86-755-8427 6832

Email & Skype: info@chipsmall.com Web: www.chipsmall.com

Address: A1208, Overseas Decoration Building, #122 Zhenhua RD., Futian, Shenzhen, China



## Precision CMOS Analog Switches

### DESCRIPTION

The DG417, DG418, DG419 monolithic CMOS analog switches were designed to provide high performance switching of analog signals. Combining low power, low leakages, high speed, low on-resistance and small physical size, the DG417 series is ideally suited for portable and battery powered industrial and military applications requiring high performance and efficient use of board space.

To achieve high-voltage ratings and superior switching performance, the DG417 series is built on Vishay Siliconix's high voltage silicon gate (HVSG) process. Break-before-make is guaranteed for the DG419, which is an SPDT configuration. An epitaxial layer prevents latchup.

Each switch conducts equally well in both directions when on, and blocks up to the power supply level when off.

The DG417 and DG418 respond to opposite control logic levels as shown in the Truth Table.

### FEATURES

- $\pm 15$  V analog signal range
- On-resistance -  $R_{DS(on)}$ : 20  $\Omega$
- Fast switching action -  $t_{ON}$ : 100 ns
- Ultra low power requirements -  $P_D$ : 35 nW
- TTL and CMOS compatible
- MiniDIP and SOIC packaging
- 44 V supply max. rating
- 44 V supply max. rating
- Compliant to RoHS directive 2002/95/EC



**RoHS\***  
COMPLIANT

### BENEFITS

- Wide dynamic range
- Low signal errors and distortion
- Break-before-make switching action
- Simple interfacing
- Reduced board space
- Improved reliability

### APPLICATIONS

- Precision test equipment
- Precision instrumentation
- Battery powered systems
- Sample-and-hold circuits
- Military radios
- Guidance and control systems
- Hard disk drives

### FUNCTIONAL BLOCK DIAGRAM AND PIN CONFIGURATION

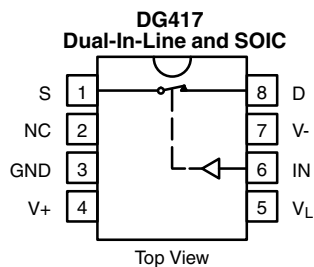

TRUTH TABLE		
Logic	DG417	DG418
0	ON	OFF
1	OFF	ON

Logic "0"  $\leq 0.8$  V

Logic "1"  $\geq 2.4$  V

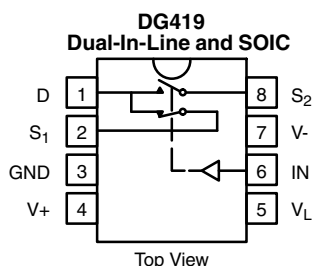

TRUTH TABLE DG419		
Logic	SW <sub>1</sub>	SW <sub>2</sub>
0	ON	OFF
1	OFF	ON

Logic "0"  $\leq 0.8$  V

Logic "1"  $\geq 2.4$  V

\* Pb containing terminations are not RoHS compliant, exemptions may apply

ORDERING INFORMATION		
Temp. Range	Package	Part Number
<b>DG417, DG418</b>		
- 40 °C to 85 °C	8-Pin Plastic MiniDIP	DG417DJ DG417DJ-E3
		DG418DJ DG418DJ-E3
	8-Pin Narrow SOIC	DG417DY DG417DY-E3 DG417DY-T1 DG417DY-T1-E3
		DG418DY DG418DY-E3 DG418DY-T1 DG418DY-T1-E3
<b>DG419</b>		
- 40 °C to 85 °C	8-Pin Plastic MiniDIP	DG419DJ DG419DJ-E3
	8-Pin Narrow SOIC	DG419DY DG419DY-E3 DG419DY-T1 DG419DY-T1-E3

ABSOLUTE MAXIMUM RATINGS			
Parameter (Voltages referenced to V-)	Limit	Unit	
V+	44	V	
GND	25		
V <sub>L</sub>	(GND - 0.3) to (V+) + 0.3		
Digital Inputs <sup>a</sup> , V <sub>S</sub> , V <sub>D</sub>	(V-) - 2 to (V+) + 2 or 30 mA, whichever occurs first		
Current, (Any Terminal) Continuous	30	mA	
Current, S or D (Pulsed at 1 ms, 10 % Duty Cycle)	100		
Storage Temperature	(AK Suffix)	- 65 to 150	°C
	(DJ, DY Suffix)	- 65 to 125	
Power Dissipation (Package) <sup>b</sup>	8-Pin Plastic MiniDIP <sup>c</sup>	400	mW
	8-Pin Narrow SOIC <sup>d</sup>	400	
	8-Pin CerDIP <sup>e</sup>	600	

Notes:

- a. Signals on S<sub>x</sub>, D<sub>x</sub>, or I<sub>Nx</sub> exceeding V+ or V- will be clamped by internal diodes. Limit forward diode current to maximum current ratings.
- b. All leads welded or soldered to PC board.
- c. Derate 6 mW/°C above 75 °C.
- d. Derate 6.5 mW/°C above 75 °C.
- e. Derate 12 mW/°C above 75 °C.

**SCHEMATIC DIAGRAM** Typical Channel

Figure 1.

<b>SPECIFICATIONS<sup>a</sup></b>										
Parameter	Symbol	Test Conditions Unless Otherwise Specified $V_+ = 15\text{ V}$ , $V_- = -15\text{ V}$ $V_L = 5\text{ V}$ , $V_{IN} = 2.4\text{ V}$ , $0.8\text{ V}^f$	Temp. <sup>b</sup>	Typ. <sup>c</sup>	A Suffix -55 °C to 125 °C		D Suffix -40 °C to 85 °C		Unit	
					Min. <sup>d</sup>	Max. <sup>d</sup>	Min. <sup>d</sup>	Max. <sup>d</sup>		
<b>Analog Switch</b>										
Analog Signal Range <sup>e</sup>	$V_{ANALOG}$		Full		-15	15	-15	15	V	
Drain-Source On-Resistance	$R_{DS(on)}$	$I_S = -10\text{ mA}$ , $V_D = \pm 12.5\text{ V}$ $V_+ = 13.5\text{ V}$ , $V_- = -13.5\text{ V}$	Room Full	20		35 45		35 45	$\Omega$	
Switch Off Leakage Current	$I_{S(off)}$	$V_+ = 16.5\text{ V}$ , $V_- = -16.5\text{ V}$ $V_D = \pm 15.5\text{ V}$ $V_S = \pm 15.5\text{ V}$	Room	-0.1	-0.25	0.25	-0.25	0.25	nA	
			Full		-20	20	-5	5		
	$I_{D(off)}$		Room Full	-0.1	-0.25 -20	0.25 20	-0.25 -5	0.25 5		
Channel Off Leakage Current	$I_{D(on)}$	$V_+ = 16.5\text{ V}$ , $V_- = -16.5\text{ V}$ $V_S = V_D = \pm 15.5\text{ V}$	DG417	-0.4	-0.4	0.4	-0.4	0.4	nA	
			DG418	Room Full		-40	40	-10		10
			DG419	Room Full	-0.4	-0.75 -60	0.75 60	-0.75 -12		0.75 12
<b>Digital Control</b>										
Input Current $V_{IN}$ Low	$I_{IL}$		Full	0.005	-0.5	0.5	-0.5	0.5	$\mu\text{A}$	
Input Current $V_{IN}$ High	$I_{IH}$		Full	0.005	-0.5	0.5	-0.5	0.5	$\mu\text{A}$	
<b>Dynamic Characteristics</b>										
Turn-On Time	$t_{ON}$	$R_L = 300\ \Omega$ , $C_L = 35\text{ pF}$ $V_S = \pm 10\text{ V}$	DG417 DG418	Room Full	100		175 250		175 250	ns
Turn-Off Time	$t_{OFF}$	See Switching Time Test Circuit	DG417 DG418	Room Full	60		145 210		145 210	
Transition Time	$t_{TRANS}$	$R_L = 300\ \Omega$ , $C_L = 35\text{ pF}$ $V_{S1} = \pm 10\text{ V}$ , $V_{S2} = \pm 10\text{ V}$	DG419	Room Full			175 250		175 250	
Break-Before-Make Time Delay (DG403)	$t_D$	$R_L = 300\ \Omega$ , $C_L = 35\text{ pF}$ $V_{S1} = V_{S2} = \pm 10\text{ V}$	DG419	Room	13	5		5		
Charge Injection	Q	$C_L = 10\text{ nF}$ , $V_{gen} = 0\text{ V}$ , $R_{gen} = 0\ \Omega$		Room	60					pC

SPECIFICATIONS <sup>a</sup>									
Parameter	Symbol	Test Conditions Unless Otherwise Specified $V_+ = 15\text{ V}$ , $V_- = -15\text{ V}$ $V_L = 5\text{ V}$ , $V_{IN} = 2.4\text{ V}$ , $0.8\text{ V}^f$	Temp. <sup>b</sup>	Typ. <sup>c</sup>	A Suffix - 55 °C to 125 °C		D Suffix - 40 °C to 85 °C		Unit
					Min. <sup>d</sup>	Max. <sup>d</sup>	Min. <sup>d</sup>	Max. <sup>d</sup>	
<b>Dynamic Characteristics</b>									
Source Off Capacitance	$C_{S(off)}$	$f = 1\text{ MHz}$ , $V_S = 0\text{ V}$	Room	8					pF
Drain Off Capacitance	$C_{D(off)}$		DG417 DG418	Room	8				
Channel On Capacitance	$C_{D(on)}$	$f = 1\text{ MHz}$ , $V_S = 0\text{ V}$	DG417 DG418	Room	30				
			DG419	Room	35				
<b>Power Supplies</b>									
Positive Supply Current	$I_+$	$V_+ = 16.5\text{ V}$ , $V_- = -16.5\text{ V}$ $V_{IN} = 0\text{ or }5\text{ V}$	Room Full	0.001		1 5		1 5	μA
Negative Supply Current	$I_-$		Room Full	- 0.001	- 1 - 5		- 1 - 5		
Logic Supply Current	$I_L$		Room Full	0.001		1 5		1 5	
Ground Current	$I_{GND}$		Room Full	- 0.0001	- 1 - 5		- 1 - 5		

SPECIFICATIONS <sup>a</sup> for Unipolar Supplies									
Parameter	Symbol	Test Conditions Unless Otherwise Specified $V_+ = 12\text{ V}$ , $V_- = 0\text{ V}$ $V_L = 5\text{ V}$ , $V_{IN} = 2.4\text{ V}$ , $0.8\text{ V}^f$	Temp. <sup>b</sup>	Typ. <sup>c</sup>	A Suffix - 55 °C to 125 °C		D Suffix - 40 °C to 85 °C		Unit
					Min. <sup>d</sup>	Max. <sup>d</sup>	Min. <sup>d</sup>	Max. <sup>d</sup>	
<b>Analog Switch</b>									
Analog Signal Range <sup>e</sup>	$V_{ANALOG}$		Full		0	12	0	12	V
Drain-Source On-Resistance	$R_{DS(on)}$	$I_S = -10\text{ mA}$ , $V_D = 3.8\text{ V}$ $V_+ = 10.8\text{ V}$	Room	40					Ω
<b>Dynamic Characteristics</b>									
Turn-On Time	$t_{ON}$	$R_L = 300\text{ Ω}$ , $C_L = 35\text{ pF}$ , $V_S = 8\text{ V}$ See Switching Time Test Circuit	Room	110					ns
Turn-Off Time	$t_{OFF}$		Room	40					
Break-Before-Make Time Delay	$t_D$	DG419 Only $R_L = 300\text{ Ω}$ , $C_L = 35\text{ pF}$	Room	60					
Charge Injection	Q	$C_L = 10\text{ nF}$ , $V_{gen} = 0\text{ V}$ , $R_{gen} = 0\text{ Ω}$	Room	5					pC
<b>Power Supplies</b>									
Positive Supply Current	$I_+$	$V_+ = 13.2\text{ V}$ , $V_L = 5.25\text{ V}$ $V_{IN} = 0\text{ or }5\text{ V}$	Room	0.001					μA
Negative Supply Current	$I_-$		Room	- 0.001					
Logic Supply Current	$I_L$		Room	0.001					
Ground Current	$I_{GND}$		Room	- 0.001					

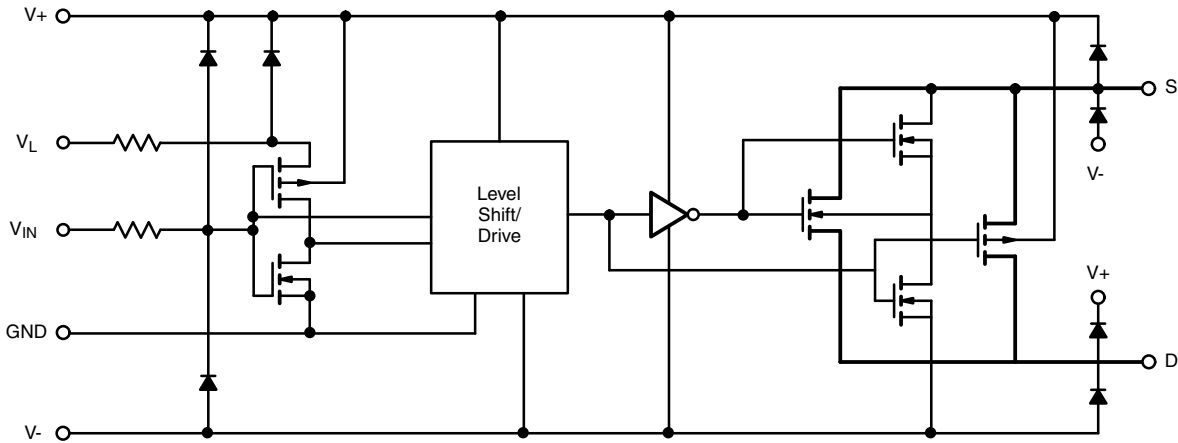
Notes:

- Refer to Process Option Flowchart.
- Room = 25 °C, Full = as determined by the operating temperature suffix.
- Typical values are for DESIGN AID ONLY, not guaranteed nor subject to production testing.
- The algebraic convention whereby the most negative value is a minimum and the most positive a maximum, is used in this data sheet.
- Guaranteed by design, not subject to production test.
- $V_{IN}$  = input voltage to perform proper function.

Stresses beyond those listed under "Absolute Maximum Ratings" may cause permanent damage to the device. These are stress ratings only, and functional operation of the device at these or any other conditions beyond those indicated in the operational sections of the specifications is not implied. Exposure to absolute maximum rating conditions for extended periods may affect device reliability.

**TYPICAL CHARACTERISTICS** 25 °C, unless otherwise noted

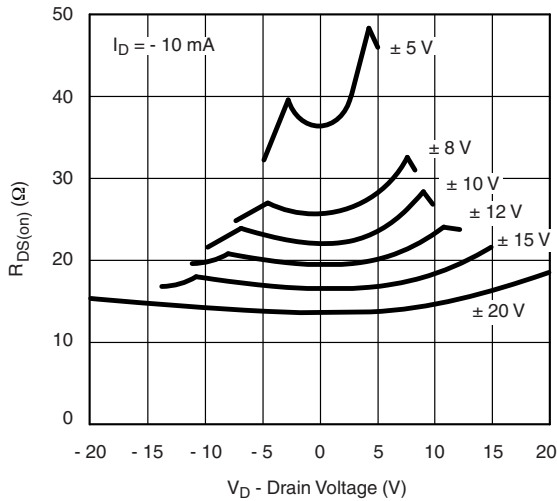

**R<sub>DS(on)</sub> vs. V<sub>D</sub> and Supply Voltage**

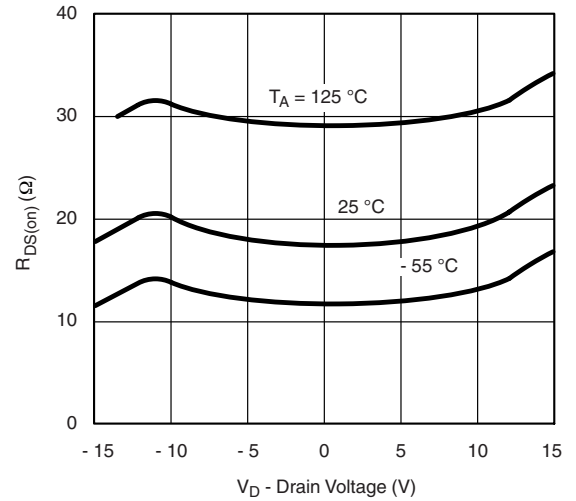

**R<sub>DS(on)</sub> vs. Temperature**

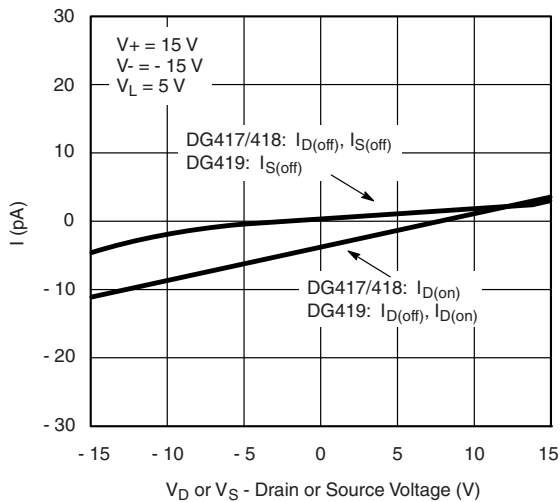

**Leakage Currents vs. Analog Voltage**

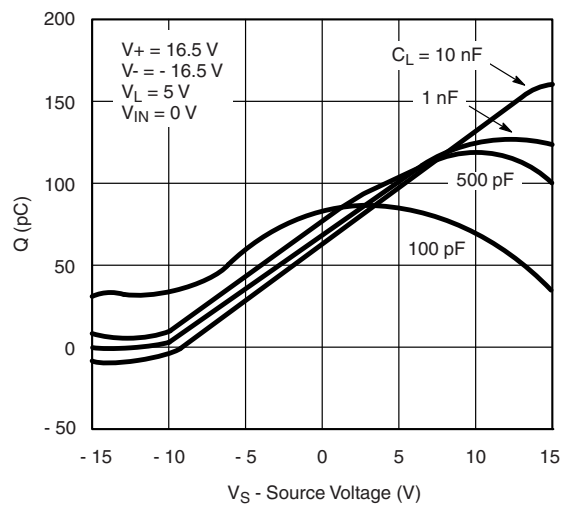

**Drain Charge Injection**

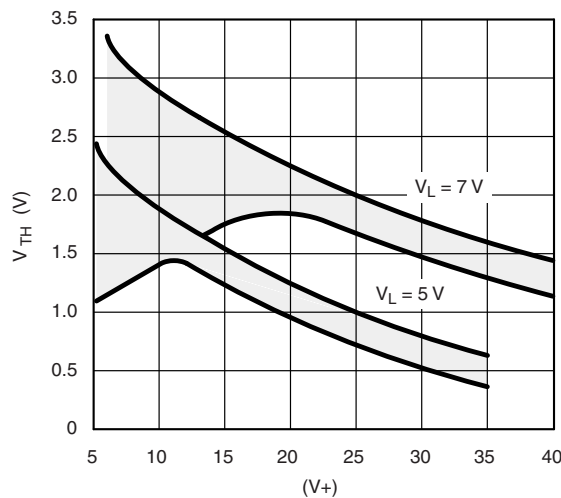

**Input Switching Threshold vs. Supply Voltages**

### TYPICAL CHARACTERISTICS 25 °C, unless otherwise noted

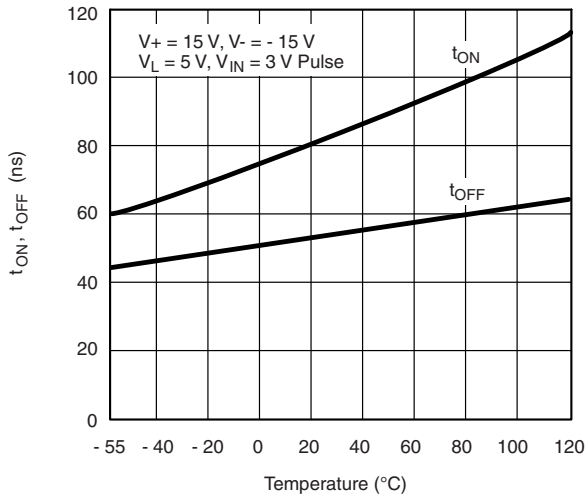

**Switching Time vs. Temperature**

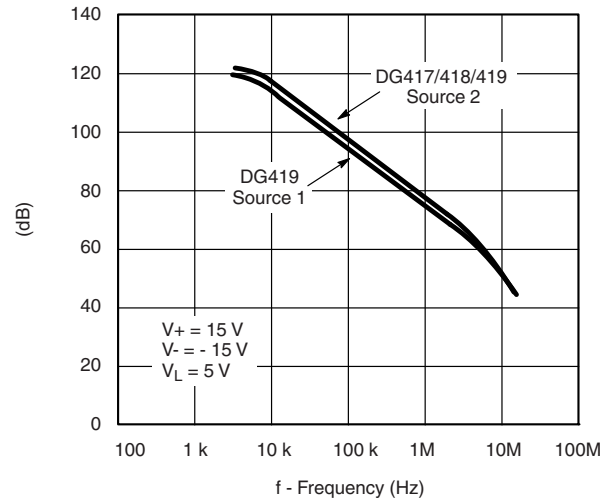

**Crosstalk and Off Isolation vs. Frequency**

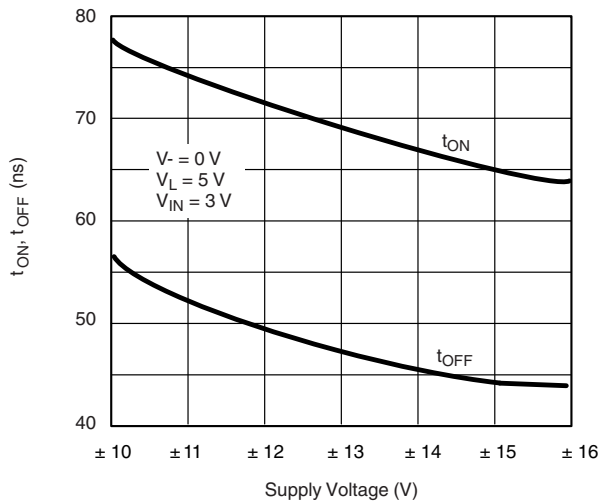

**Switching Time vs. Supply Voltages**

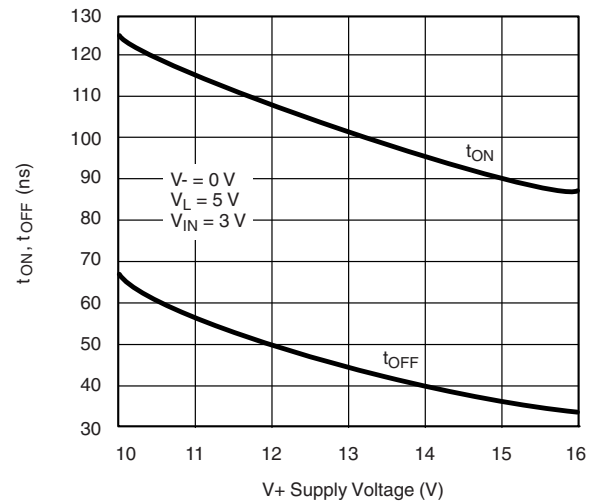

**Switching Time vs.  $V_+$**

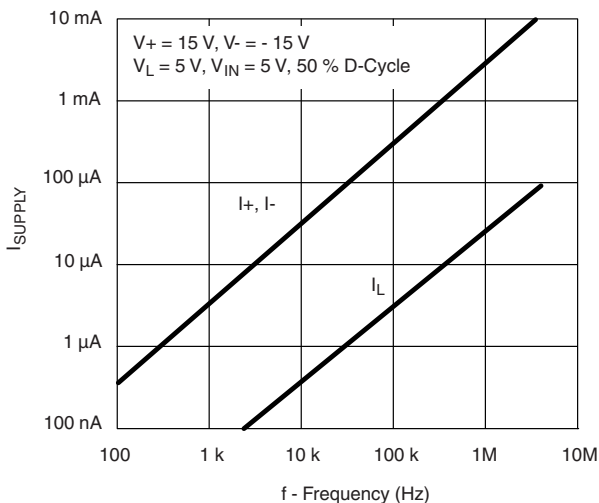

**Power Supply Currents vs. Switching Frequency**

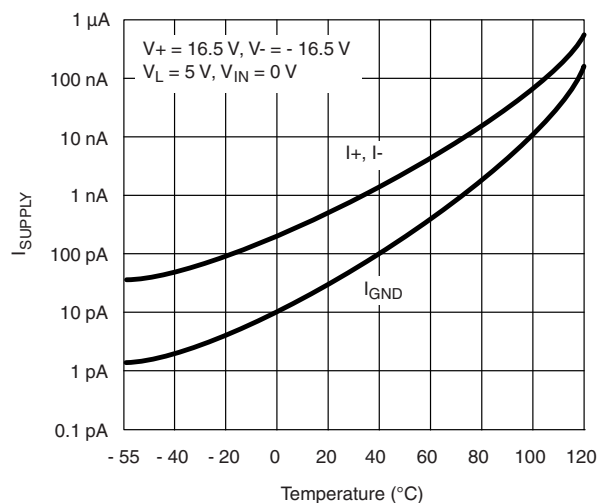

**Supply Current vs. Temperature**

## TEST CIRCUITS

$V_O$  is the steady state output with the switch on.

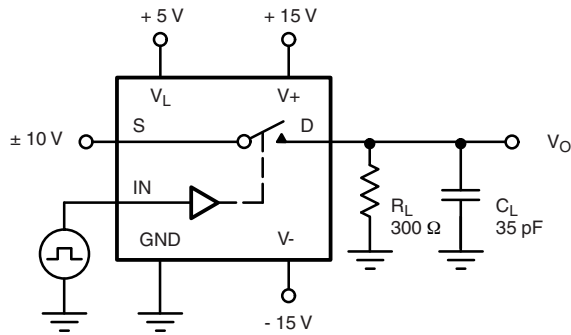

$C_L$  (includes fixture and stray capacitance)

$$V_O = V_S \frac{R_L}{R_L + r_{DS(on)}}$$

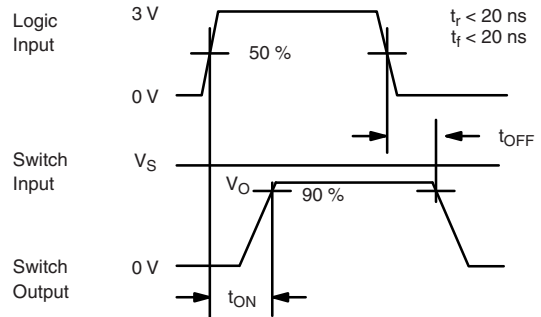

Note: Logic input waveform is inverted for switches that have the opposite logic sense.

Figure 2. Switching Time (DG417, DG418)

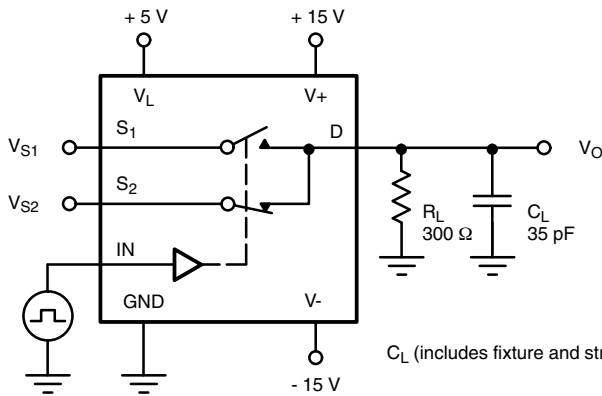

$C_L$  (includes fixture and stray capacitance)

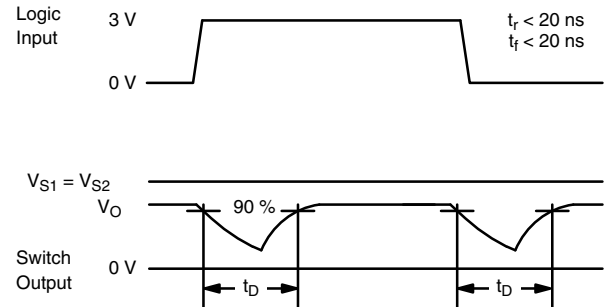
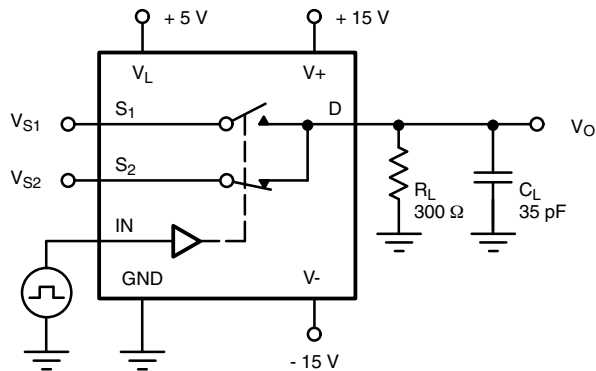

Figure 3. Break-Before-Make (DG419)



$C_L$  (includes fixture and stray capacitance)

$$V_O = V_S \frac{R_L}{R_L + r_{DS(on)}}$$

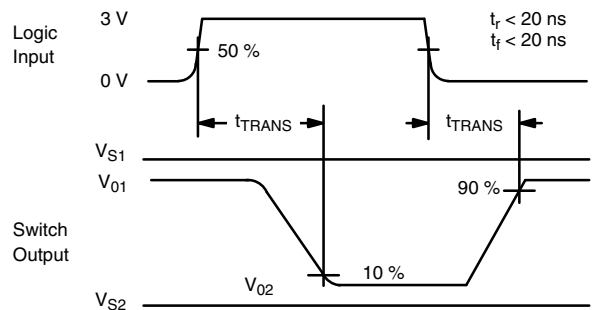

Figure 4. Transition Time (DG419)



## TEST CIRCUITS

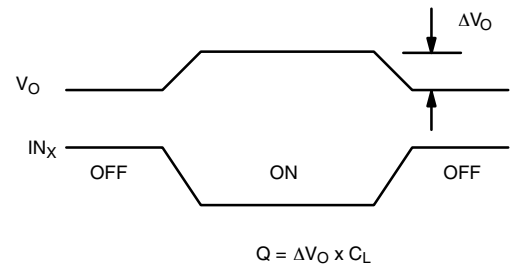
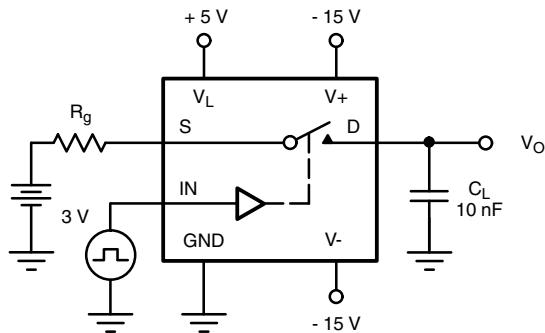

Figure 5. Charge Injection

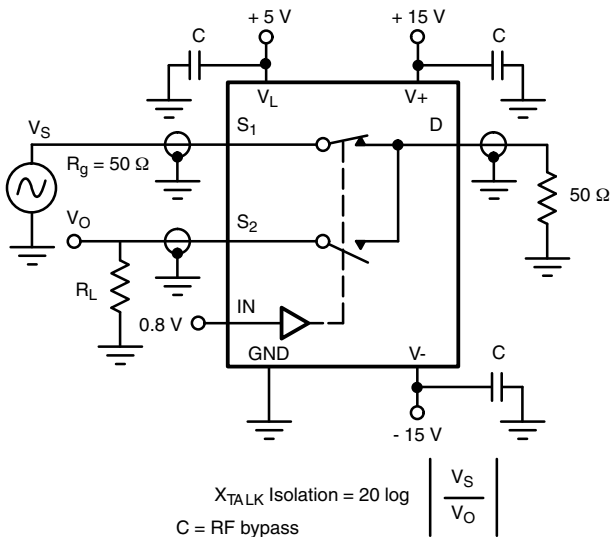

Figure 6. Crosstalk (DG419)

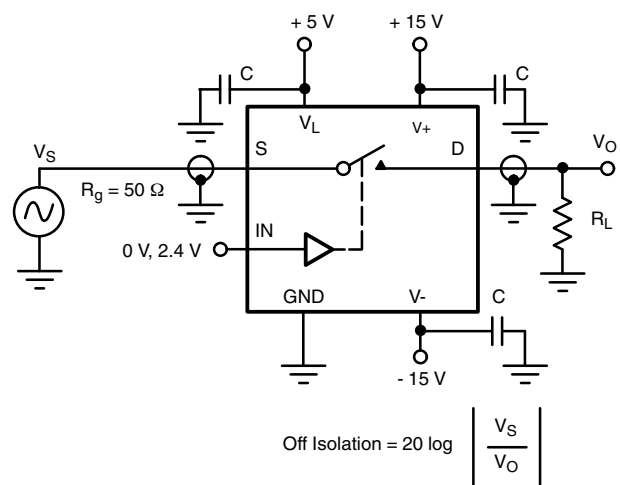

Figure 7. Off Isolation

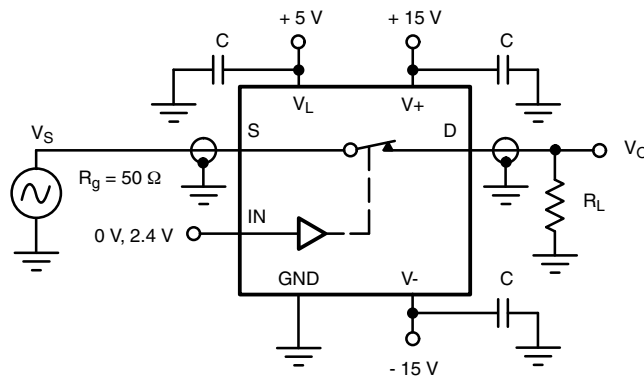
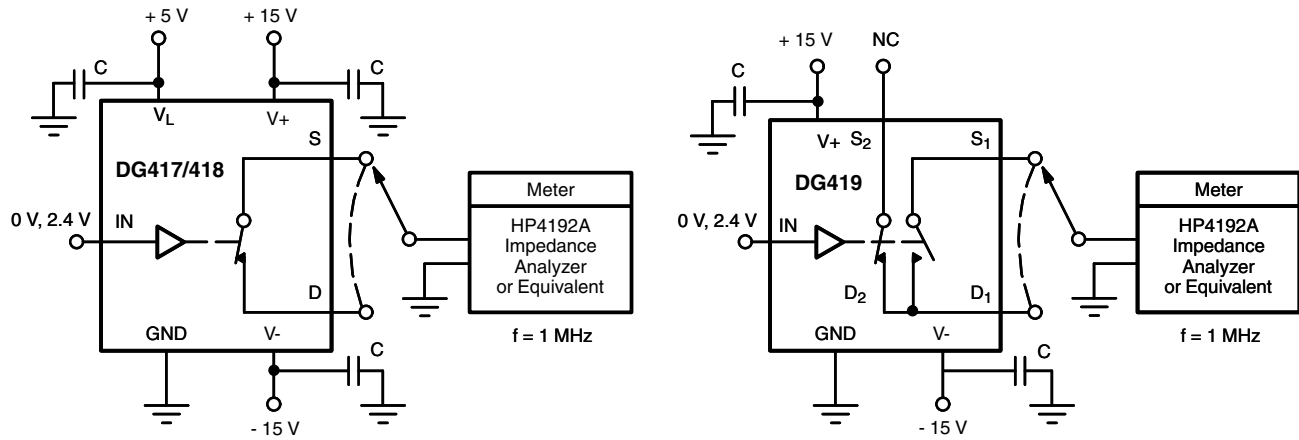

Figure 8. Insertion Loss

**TEST CIRCUITS**

**Figure 9. Source/Drain Capacitances**
**APPLICATIONS**
**Switched Signal Powers Analog Switch**

The analog switch in Figure 10 derives power from its input signal, provided the input signal amplitude exceeds 4 V and its frequency exceeds 1 kHz.

This circuit is useful when signals have to be routed to either of two remote loads. Only three conductors are required: one for the signal to be switched, one for the control signal and a common return.

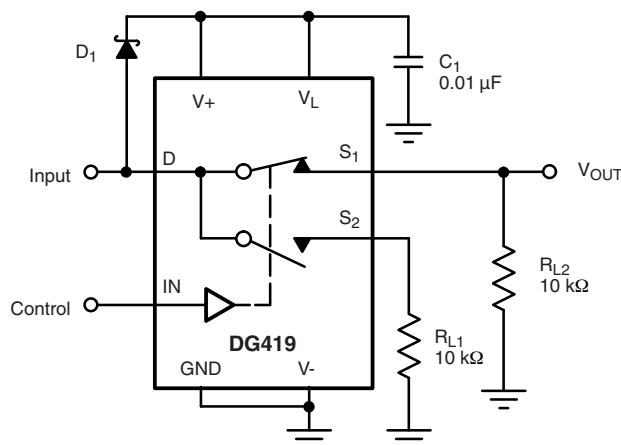
A positive input pulse turns on the clamping diode  $D_1$  and charges  $C_1$ . The charge stored on  $C_1$  is used to power the chip; operation is satisfactory because the switch requires less than  $1 \mu\text{A}$  of stand-by supply current. Loading of the signal source is imperceptible. The DG419's on-resistance is a low  $100 \Omega$  for a 5 V input signal.

**Figure 10. Switched Signal Powers Remote SPDT Analog Switch**

## APPLICATIONS

### Micropower UPS Transfer Switch

When  $V_{CC}$  drops to 3.3 V, the DG417 changes states, closing  $SW_1$  and connecting the backup cell, as shown in Figure 10.  $D_1$  prevents current from leaking back towards the rest of the circuit. Current consumption by the CMOS analog switch is around 100 pA; this ensures that most of the power available is applied to the memory, where it is really needed. In the stand-by mode, hundreds of A are sufficient to retain memory data.

When the 5 V supply comes back up, the resistor divider senses the presence of at least 3.5 V, and causes a new change of state in the analog switch, restoring normal operation.

### Programmable Gain Amplifier

The DG419, as shown in figure 11, allows accurate gain selection in a small package. Switching into virtual ground reduces distortion caused by  $R_{DS(on)}$  variation as a function of analog signal amplitude.

### GaAs FET Driver

The DG419, as shown in figure 12 may be used as a GaAs FET driver. It translates a TTL control signal into - 8 V, 0 V level outputs to drive the gate.

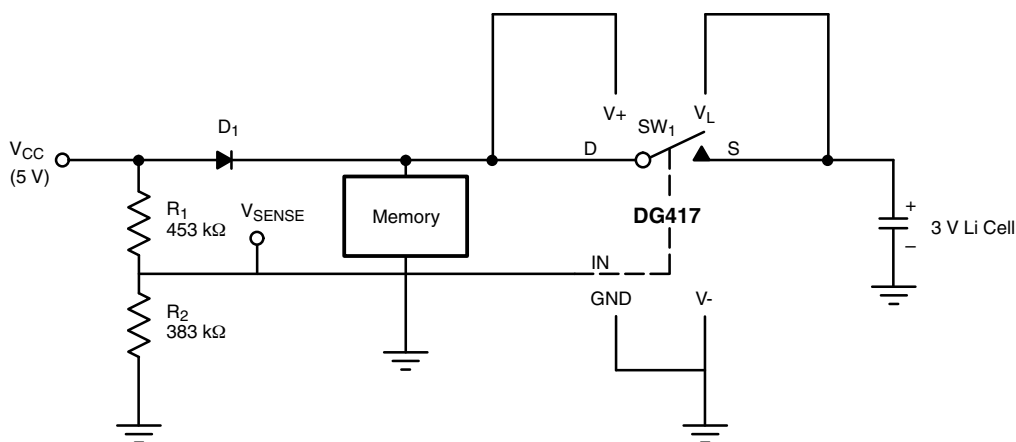

Figure 11. Micropower UPS Circuit

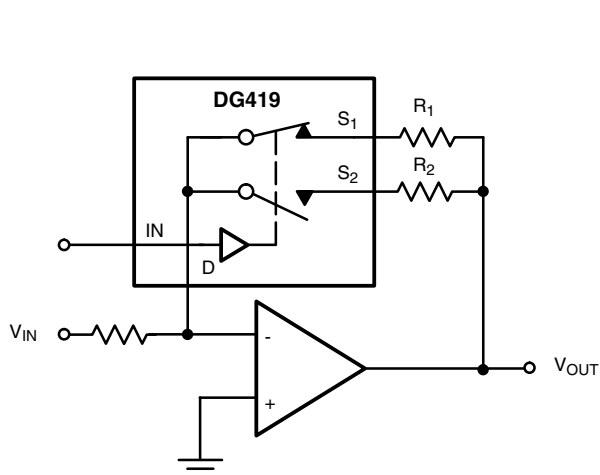

Figure 12. Programmable Gain Amplifier

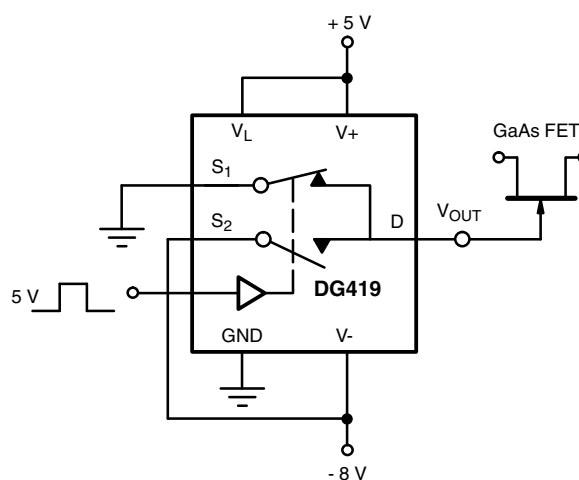
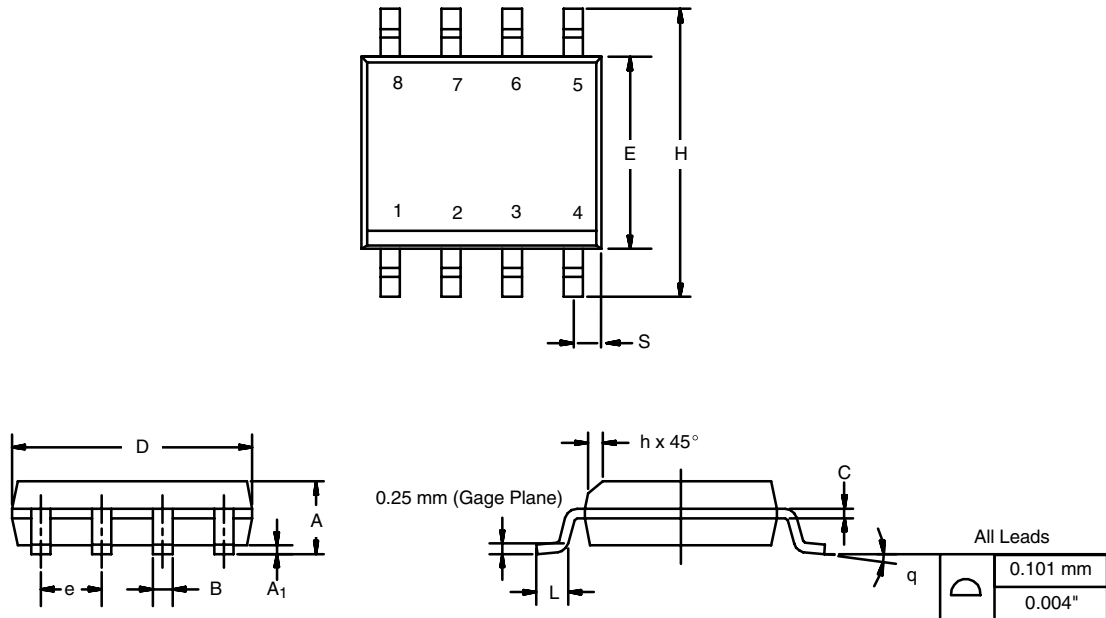

Figure 13. GaAs FET Driver

Vishay Siliconix maintains worldwide manufacturing capability. Products may be manufactured at one of several qualified locations. Reliability data for Silicon Technology and Package Reliability represent a composite of all qualified locations. For related documents such as package/tape drawings, part marking, and reliability data, see [www.vishay.com/ppq?70051](http://www.vishay.com/ppq?70051).

## SOIC (NARROW): 8-LEAD

JEDEC Part Number: MS-012



DIM	MILLIMETERS		INCHES	
	Min	Max	Min	Max
A	1.35	1.75	0.053	0.069
A <sub>1</sub>	0.10	0.20	0.004	0.008
B	0.35	0.51	0.014	0.020
C	0.19	0.25	0.0075	0.010
D	4.80	5.00	0.189	0.196
E	3.80	4.00	0.150	0.157
e	1.27 BSC		0.050 BSC	
H	5.80	6.20	0.228	0.244
h	0.25	0.50	0.010	0.020
L	0.50	0.93	0.020	0.037
q	0°	8°	0°	8°
S	0.44	0.64	0.018	0.026
ECN: C-06527-Rev. I, 11-Sep-06				
DWG: 5498				



**PDIP: 8-LEAD**

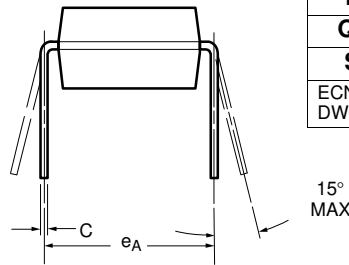
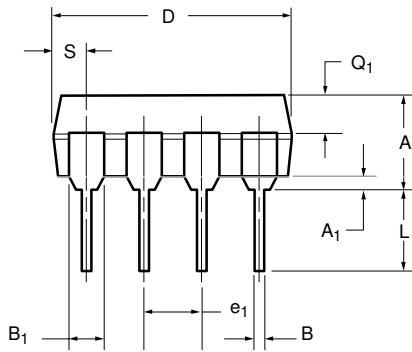
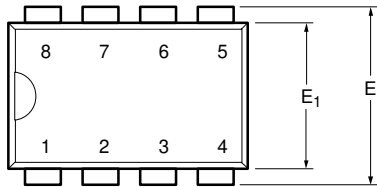

Dim	MILLIMETERS		INCHES	
	Min	Max	Min	Max
<b>A</b>	3.81	5.08	0.150	0.200
<b>A<sub>1</sub></b>	0.38	1.27	0.015	0.050
<b>B</b>	0.38	0.51	0.015	0.020
<b>B<sub>1</sub></b>	0.89	1.65	0.035	0.065
<b>C</b>	0.20	0.30	0.008	0.012
<b>D</b>	9.02	10.92	0.355	0.430
<b>E</b>	7.62	8.26	0.300	0.325
<b>E<sub>1</sub></b>	5.59	7.11	0.220	0.280
<b>e<sub>1</sub></b>	2.29	2.79	0.090	0.110
<b>e<sub>A</sub></b>	7.37	7.87	0.290	0.310
<b>L</b>	2.79	3.81	0.110	0.150
<b>Q<sub>1</sub></b>	1.27	2.03	0.050	0.080
<b>S</b>	0.76	1.65	0.030	0.065

ECN: S-03946—Rev. E, 09-Jul-01  
DWG: 5478

NOTE: End leads may be half leads.



**CERDIP: 8-LEAD**

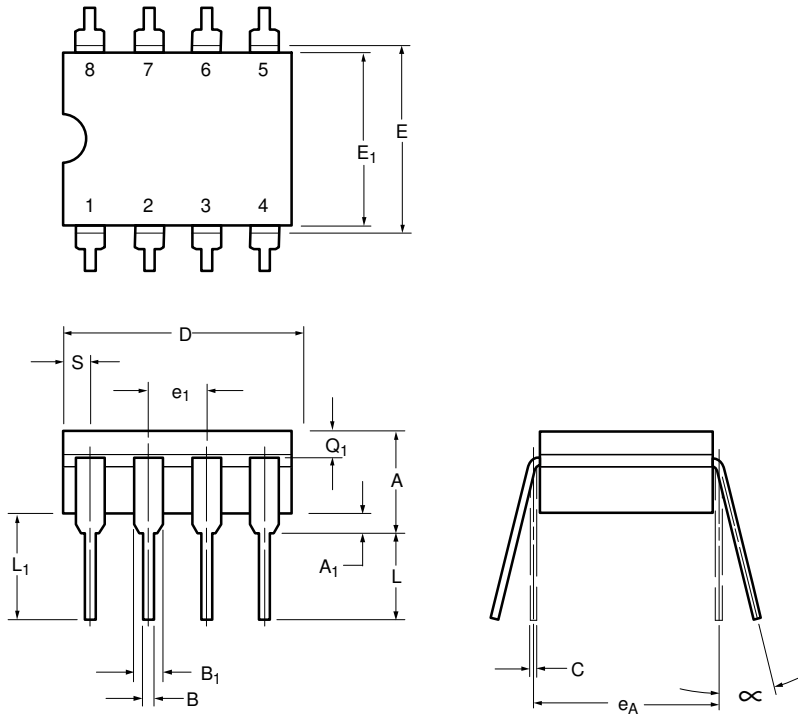

Dim	MILLIMETERS		INCHES	
	Min	Max	Min	Max
<b>A</b>	4.06	5.08	0.160	0.200
<b>A<sub>1</sub></b>	0.51	1.14	0.020	0.045
<b>B</b>	0.38	0.51	0.015	0.020
<b>B<sub>1</sub></b>	1.14	1.65	0.045	0.065
<b>C</b>	0.20	0.30	0.008	0.012
<b>D</b>	9.40	10.16	0.370	0.400
<b>E</b>	7.62	8.26	0.300	0.325
<b>E<sub>1</sub></b>	6.60	7.62	0.260	0.300
<b>e<sub>1</sub></b>	2.54 BSC		0.100 BSC	
<b>e<sub>A</sub></b>	7.62 BSC		0.300 BSC	
<b>L</b>	3.18	3.81	0.125	0.150
<b>L<sub>1</sub></b>	3.18	5.08	0.150	0.200
<b>Q<sub>1</sub></b>	1.27	2.16	0.050	0.085
<b>S</b>	0.64	1.52	0.025	0.060
$\infty$	0°	15°	0°	15°

ECN: S-03946—Rev. C, 09-Jul-01  
DWG: 5348



# Mounting LITTLE FOOT®, SO-8 Power MOSFETs

Wharton McDaniel

Surface-mounted LITTLE FOOT power MOSFETs use integrated circuit and small-signal packages which have been modified to provide the heat transfer capabilities required by power devices. Leadframe materials and design, molding compounds, and die attach materials have been changed, while the footprint of the packages remains the same.

See Application Note 826, *Recommended Minimum Pad Patterns With Outline Drawing Access for Vishay Siliconix MOSFETs*, (<http://www.vishay.com/ppg?72286>), for the basis of the pad design for a LITTLE FOOT SO-8 power MOSFET. In converting this recommended minimum pad to the pad set for a power MOSFET, designers must make two connections: an electrical connection and a thermal connection, to draw heat away from the package.

In the case of the SO-8 package, the thermal connections are very simple. Pins 5, 6, 7, and 8 are the drain of the MOSFET for a single MOSFET package and are connected together. In a dual package, pins 5 and 6 are one drain, and pins 7 and 8 are the other drain. For a small-signal device or integrated circuit, typical connections would be made with traces that are 0.020 inches wide. Since the drain pins serve the additional function of providing the thermal connection to the package, this level of connection is inadequate. The total cross section of the copper may be adequate to carry the current required for the application, but it presents a large thermal impedance. Also, heat spreads in a circular fashion from the heat source. In this case the drain pins are the heat sources when looking at heat spread on the PC board.

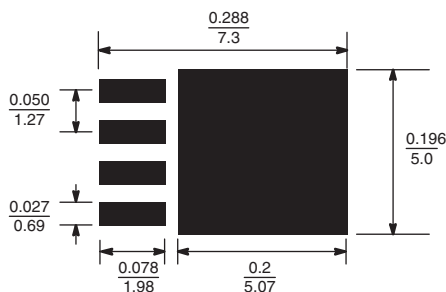

Figure 1. Single MOSFET SO-8 Pad Pattern With Copper Spreading

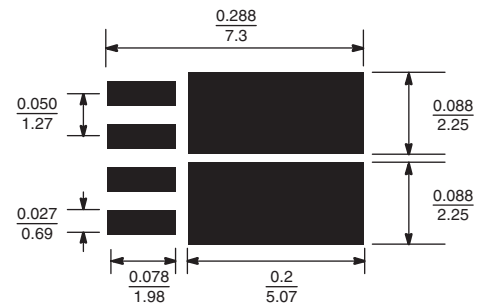

Figure 2. Dual MOSFET SO-8 Pad Pattern With Copper Spreading

The minimum recommended pad patterns for the single-MOSFET SO-8 with copper spreading (Figure 1) and dual-MOSFET SO-8 with copper spreading (Figure 2) show the starting point for utilizing the board area available for the heat-spreading copper. To create this pattern, a plane of copper overlies the drain pins. The copper plane connects the drain pins electrically, but more importantly provides planar copper to draw heat from the drain leads and start the process of spreading the heat so it can be dissipated into the ambient air. These patterns use all the available area underneath the body for this purpose.

Since surface-mounted packages are small, and reflow soldering is the most common way in which these are affixed to the PC board, “thermal” connections from the planar copper to the pads have not been used. Even if additional planar copper area is used, there should be no problems in the soldering process. The actual solder connections are defined by the solder mask openings. By combining the basic footprint with the copper plane on the drain pins, the solder mask generation occurs automatically.

A final item to keep in mind is the width of the power traces. The absolute minimum power trace width must be determined by the amount of current it has to carry. For thermal reasons, this minimum width should be at least 0.020 inches. The use of wide traces connected to the drain plane provides a low impedance path for heat to move away from the device.

## RECOMMENDED MINIMUM PADS FOR SO-8



Recommended Minimum Pads  
Dimensions in Inches/(mm)

[Return to Index](#)





## Disclaimer

ALL PRODUCT, PRODUCT SPECIFICATIONS AND DATA ARE SUBJECT TO CHANGE WITHOUT NOTICE TO IMPROVE RELIABILITY, FUNCTION OR DESIGN OR OTHERWISE.

Vishay Intertechnology, Inc., its affiliates, agents, and employees, and all persons acting on its or their behalf (collectively, "Vishay"), disclaim any and all liability for any errors, inaccuracies or incompleteness contained in any datasheet or in any other disclosure relating to any product.

Vishay makes no warranty, representation or guarantee regarding the suitability of the products for any particular purpose or the continuing production of any product. To the maximum extent permitted by applicable law, Vishay disclaims (i) any and all liability arising out of the application or use of any product, (ii) any and all liability, including without limitation special, consequential or incidental damages, and (iii) any and all implied warranties, including warranties of fitness for particular purpose, non-infringement and merchantability.

Statements regarding the suitability of products for certain types of applications are based on Vishay's knowledge of typical requirements that are often placed on Vishay products in generic applications. Such statements are not binding statements about the suitability of products for a particular application. It is the customer's responsibility to validate that a particular product with the properties described in the product specification is suitable for use in a particular application. Parameters provided in datasheets and/or specifications may vary in different applications and performance may vary over time. All operating parameters, including typical parameters, must be validated for each customer application by the customer's technical experts. Product specifications do not expand or otherwise modify Vishay's terms and conditions of purchase, including but not limited to the warranty expressed therein.

Except as expressly indicated in writing, Vishay products are not designed for use in medical, life-saving, or life-sustaining applications or for any other application in which the failure of the Vishay product could result in personal injury or death. Customers using or selling Vishay products not expressly indicated for use in such applications do so at their own risk. Please contact authorized Vishay personnel to obtain written terms and conditions regarding products designed for such applications.

No license, express or implied, by estoppel or otherwise, to any intellectual property rights is granted by this document or by any conduct of Vishay. Product names and markings noted herein may be trademarks of their respective owners.

## Material Category Policy

**Vishay Intertechnology, Inc. hereby certifies that all its products that are identified as RoHS-Compliant fulfill the definitions and restrictions defined under Directive 2011/65/EU of The European Parliament and of the Council of June 8, 2011 on the restriction of the use of certain hazardous substances in electrical and electronic equipment (EEE) - recast, unless otherwise specified as non-compliant.**

**Please note that some Vishay documentation may still make reference to RoHS Directive 2002/95/EC. We confirm that all the products identified as being compliant to Directive 2002/95/EC conform to Directive 2011/65/EU.**

**Vishay Intertechnology, Inc. hereby certifies that all its products that are identified as Halogen-Free follow Halogen-Free requirements as per JEDEC JS709A standards. Please note that some Vishay documentation may still make reference to the IEC 61249-2-21 definition. We confirm that all the products identified as being compliant to IEC 61249-2-21 conform to JEDEC JS709A standards.**