



Chipsmall Limited consists of a professional team with an average of over 10 year of expertise in the distribution of electronic components. Based in Hongkong, we have already established firm and mutual-benefit business relationships with customers from,Europe,America and south Asia,supplying obsolete and hard-to-find components to meet their specific needs.

With the principle of "Quality Parts,Customers Priority,Honest Operation,and Considerate Service",our business mainly focus on the distribution of electronic components. Line cards we deal with include Microchip,ALPS,ROHM,Xilinx,Pulse,ON,Everlight and Freescale. Main products comprise IC,Modules,Potentiometer,IC Socket,Relay,Connector.Our parts cover such applications as commercial,industrial, and automotives areas.

We are looking forward to setting up business relationship with you and hope to provide you with the best service and solution. Let us make a better world for our industry!



Contact us

Tel: +86-755-8981 8866 Fax: +86-755-8427 6832

Email & Skype: info@chipsmall.com Web: www.chipsmall.com

Address: A1208, Overseas Decoration Building, #122 Zhenhua RD., Futian, Shenzhen, China



**NOT RECOMMENDED FOR NEW DESIGNS
RECOMMENDED REPLACEMENT PART
DG408**

CMOS Analog Multiplexers

The DG508A is a CMOS Monolithic 8-Channel Analog Multiplexer, which can also be used as a demultiplexer. An enable input is provided. When the enable input is high, a channel is selected by the address inputs, and when low, all channels are off.

A channel in the ON state conducts current equally well in both directions. In the OFF state each channel blocks voltages up to the supply rails. The address inputs and the enable input are TTL and CMOS compatible over the full specified operating temperature range.

The DG508A is pinout compatible with the industry standard devices.

Ordering Information

PART NUMBER	TEMP. RANGE (°C)	PACKAGE	PKG. DWG. #
DG508AAK	-55 to +125	16 Ld CERDIP	F16.3
DG508ABK	-25 to +85	16 Ld CERDIP	F16.3
DG508ACJ	0 to +70	16 Ld PDIP	E16.3
DG508ACJZ (See Note)	0 to +70	16 Ld PDIP (Pb-free)	E16.3

NOTE: Intersil Pb-free products employ special Pb-free material sets; molding compounds/die attach materials and 100% matte tin plate termination finish, which is compatible with both SnPb and Pb-free soldering operations. Intersil Pb-free products are MSL classified at Pb-free peak reflow temperatures that meet or exceed the Pb-free requirements of IPC/JEDEC J STD-020C.

Pinout

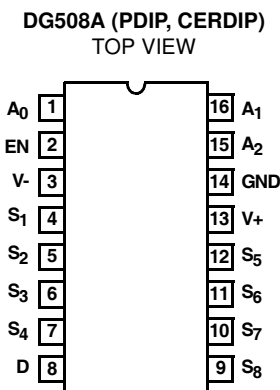

Features

- Low Power Consumption
- TTL and CMOS-Compatible Address and Enable Inputs
- 44V Maximum Power Supply Rating
- High Latch-Up Immunity
- Break-Before-Make Switching
- Alternate Source
- Pb-Free Available (RoHS Compliant)

Applications

- Data Acquisition Systems
- Communication Systems
- Signal Multiplexing/Demultiplexing
- Audio Signal Multiplexing

Truth Table

DG508A				
A ₂	A ₁	A ₀	EN	ON SWITCH
X	X	X	0	None
0	0	0	1	1
0	0	1	1	2
0	1	0	1	3
0	1	1	1	4
1	0	0	1	5
1	0	1	1	6
1	1	0	1	7
1	1	1	1	8

A₀, A₁, A₂, EN
Logic "1" = V_{AH} ≥ 2.4V, Logic "0" = V_{AL} ≤ 0.8V

Functional Diagram

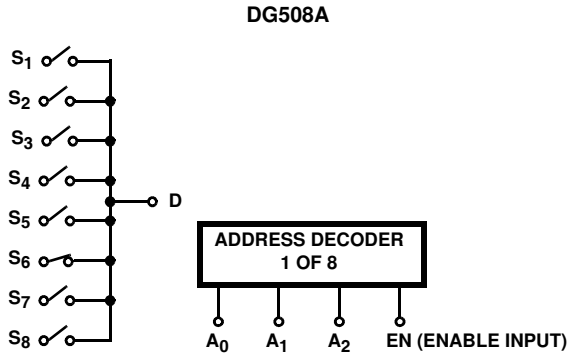

3 Line Binary Address Inputs
(1 0 1) and EN = 1
Above example shows channel 6 turned ON.

Schematic Diagram

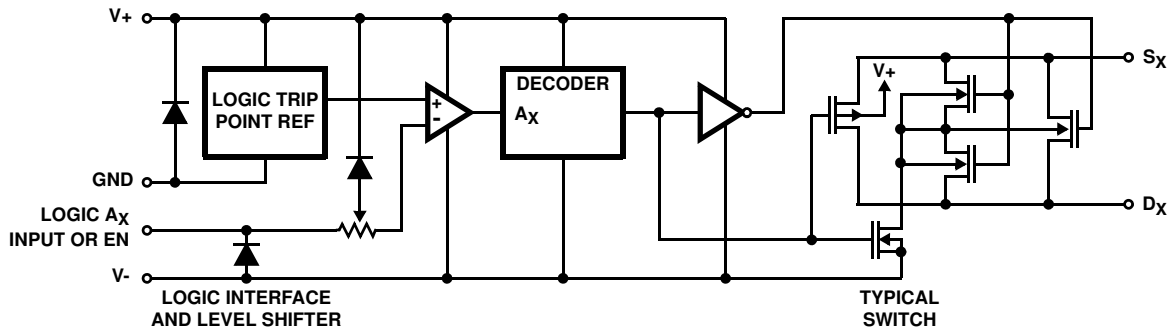

Absolute Maximum Ratings

V+ to V-	44V
V- to Ground	25V
Digital Inputs, V _S , V _D (Note 1)	(V- -2V) To (V+ +2V)
Continuous Current, (Any Terminal Except S or D)	30mA
Continuous Current, (S or D)	20mA
Peak Current, S or D (Pulsed 1ms, 10% Duty Cycle Max)	40mA

Operating Conditions

Temperature Range	
“A” Suffix	-55°C to 125°C
“B” Suffix	-25°C to 85°C
“C” Suffix	0°C to 70°C

Thermal Information

Thermal Resistance (Typical, Note 2)	θ_{JA} (°C/W)	θ_{JC} (°C/W)
16 Ld CERDIP Package	75	20
16 Ld PDIP Package	90	N/A
Maximum Junction Temperature		
CERDIP Package		175°C
PDIP Package		150°C
Maximum Storage Temperature		
“A” and “B” Suffix		-65°C to 150°C
“C” Suffix		-65°C to 125°C
Maximum Lead Temperature (Soldering 10s)		300°C

CAUTION: Stresses above those listed in “Absolute Maximum Ratings” may cause permanent damage to the device. This is a stress only rating and operation of the device at these or any other conditions above those indicated in the operational sections of this specification is not implied.

NOTES:

1. Signals on S_X, D, E_N, or A_X exceeding V+ or V- are clamped by internal diodes. Limit diode current to maximum current ratings.
2. θ_{JA} is measured with the component mounted on an evaluation PC board in free air.

Electrical Specifications T_A = 25°C, V+ = +15V, V- = -15V, GND = 0V, V_{EN} = 2.4V, Unless Otherwise Specified

PARAMETER	TEST CONDITIONS	“A” SUFFIX			“B” AND “C” SUFFIX			UNITS	
		(NOTE 4) MIN	(NOTE 3) TYP	(NOTE 4) MAX	(NOTE 4) MIN	(NOTE 3) TYP	(NOTE 4) MAX		
DYNAMIC CHARACTERISTICS									
Switching Time of Multiplexer, t _{TRANSITION}	See Figure 1	-	0.6	1	-	0.6	-	μs	
Break-Before-Make Interval, t _{OPEN}	See Figure 3	-	0.2	-	-	0.2	-	μs	
Enable Turn-ON Time, t _{ON(EN)}	See Figure 2	-	1	1.5	-	1	-	μs	
Enable Turn-OFF Time, t _{OFF(EN)}	See Figure 2	-	0.4	1.0	-	0.4	-	μs	
OFF Isolation, OIRR	V _{EN} = 0V, R _L = 1kΩ, C _L = 15pF, V _S = 7V _{RMS} , f = 500kHz (Note 5)	-	68	-	-	68	-	dB	
Source OFF Capacitance, C _{S(OFF)}	V _S = 0V, V _{EN} = 0V, f = 140kHz	-	5	-	-	5	-	pF	
Drain OFF Capacitance, C _{D(OFF)}	V _D = 0V, V _{EN} = 0V, f = 140kHz	-	25	-	-	25	-	pF	
Charge Injection, Q	See Figure 4	-	4	-	-	4	-	pC	
DIGITAL INPUT CHARACTERISTICS									
Address Input Current, Input Voltage High, I _{AH}	V _A = 2.4V	-10	-0.002	-	-10	-0.002	-	μA	
	V _A = 15V	-	0.006	10	-	0.006	10	μA	
Address Input Current Input Voltage Low, I _{AL}	V _{EN} = 2.4V	V _A = 0V	-10	-0.002	-	-10	-0.002	μA	
	V _{EN} = 0V		-10	-0.002	-	-10	-0.0002	μA	
ANALOG SWITCH CHARACTERISTICS									
Analog Signal Range, V _{ANALOG}	(Note 7)	-15	-	+15	-15	-	+15	V	
Drain-Source ON Resistance, r _{DS(ON)}	Sequence Each Switch ON V _{AL} = 0.8V, V _{AH} = 2.4V	I _S = -200μA, V _D = +10V	-	270	400	-	270	450	Ω
		I _S = -200μA, V _D = -10V	-	230	400	-	230	450	Ω
r _{DS(ON)} Matching Between Channels	-10V ≤ V _S ≤ +10V $\Delta r_{DS(ON)} = \frac{r_{DS(ON)MAX} - r_{DS(ON)MIN}}{r_{DS(ON)AVG}}$	-	6	-	-	6	-	%	

DG508A

Electrical Specifications $T_A = 25^\circ\text{C}$, $V_+ = +15\text{V}$, $V_- = -15\text{V}$, $\text{GND} = 0\text{V}$, $V_{\text{EN}} = 2.4\text{V}$, Unless Otherwise Specified (Continued)

PARAMETER	TEST CONDITIONS		"A" SUFFIX			"B" AND "C" SUFFIX			UNITS
			(NOTE 4) MIN	(NOTE 3) TYP	(NOTE 4) MAX	(NOTE 4) MIN	(NOTE 3) TYP	(NOTE 4) MAX	
Source OFF Leakage Current, $I_{\text{S(OFF)}}$	$V_{\text{EN}} = 0\text{V}$	$V_{\text{S}} = +10\text{V}$, $V_{\text{D}} = -10\text{V}$	-1	0.002	1	-5	0.002	5	nA
		$V_{\text{S}} = -10\text{V}$, $V_{\text{D}} = +10\text{V}$	-1	-0.005	1	-5	-0.005	5	nA
Drain OFF Leakage Current, $I_{\text{D(OFF)}}$	$V_{\text{EN}} = 0\text{V}$	$V_{\text{S}} = -10\text{V}$, $V_{\text{D}} = +10\text{V}$	-	0.01	10	-	0.01	20	nA
		$V_{\text{S}} = +10\text{V}$, $V_{\text{D}} = -10\text{V}$	-10	-0.015	-	-20	-0.015	-	nA
Drain ON Leakage Current, $I_{\text{D(ON)}}$	(Note 6) Sequence Each Switch ON $V_{\text{AL}} = 0.8\text{V}$, $V_{\text{AH}} = 2.4\text{V}$	$V_{\text{D}} = V_{\text{S(ALL)}} = +10\text{V}$	-	0.015	10	-	0.015	20	nA
		$V_{\text{D}} = V_{\text{S(ALL)}} = -10\text{V}$	-10	-0.03	-	-20	-0.03	-	nA
POWER SUPPLY CHARACTERISTICS									
Positive Supply Current, I_+	$V_{\text{EN}} = 5.0\text{V}$ (Enabled) or		-	1.3	2.4	-	1.3	2.4	mA
Negative Supply Current, I_-	$V_{\text{EN}} = 0\text{V}$ (Standby), $V_{\text{A}} = 0\text{V}$		-1.5	-0.7	-	-1.5	-0.7	-	mA

Electrical Specifications $T_A =$ Over Operating Temperature Range, $V_+ = +15\text{V}$, $V_- = -15\text{V}$, $\text{GND} = 0\text{V}$, $V_{\text{EN}} = 2.4\text{V}$, Unless Otherwise Specified

PARAMETER	TEST CONDITIONS		"A" SUFFIX			UNITS	
			MIN	(NOTE 3) TYP	MAX		
DIGITAL INPUT CHARACTERISTICS							
Address Input Current, Input Voltage High, I_{AH}	$V_{\text{A}} = 2.4\text{V}$		-30	-	-	μA	
	$V_{\text{A}} = 15\text{V}$		-	-	30	μA	
Address Input Current Input Voltage Low, I_{AL}	$V_{\text{EN}} = 2.4\text{V}$		$V_{\text{A}} = 0\text{V}$		-30	μA	
	$V_{\text{EN}} = 0\text{V}$				-30	μA	
ANALOG SWITCH CHARACTERISTICS							
Analog Signal Range, V_{ANALOG}	(Note 7)		-15	-	+15	V	
Drain-Source ON Resistance, $r_{\text{DS(ON)}}$	Sequence Each Switch ON $V_{\text{AL}} = 0.8\text{V}$, $V_{\text{AH}} = 2.4\text{V}$		$I_{\text{S}} = -200\mu\text{A}$, $V_{\text{D}} = +10\text{V}$	-	-	500	Ω
			$I_{\text{S}} = -200\mu\text{A}$, $V_{\text{D}} = -10\text{V}$	-	-	500	Ω
Source OFF Leakage Current, $I_{\text{S(OFF)}}$	$V_{\text{EN}} = 0\text{V}$		$V_{\text{S}} = +10\text{V}$, $V_{\text{D}} = -10\text{V}$	-	-	50	nA
			$V_{\text{S}} = -10\text{V}$, $V_{\text{D}} = +10\text{V}$	-50	-	-	nA
Drain OFF Leakage Current, $I_{\text{D(OFF)}}$	$V_{\text{EN}} = 0\text{V}$		$V_{\text{S}} = -10\text{V}$, $V_{\text{D}} = +10\text{V}$	-	-	200	nA
			$V_{\text{S}} = +10\text{V}$, $V_{\text{D}} = -10\text{V}$	-200	-	-	nA
Drain ON Leakage Current, $I_{\text{D(ON)}}$	(Note 6) Sequence Each Switch ON $V_{\text{AL}} = 0.8\text{V}$, $V_{\text{AH}} = 2.4\text{V}$		$V_{\text{D}} = V_{\text{S(ALL)}} = +10\text{V}$	-	-	200	nA
			$V_{\text{D}} = V_{\text{S(ALL)}} = -10\text{V}$	-200	-	-	nA
POWER SUPPLY CHARACTERISTICS							
Positive Supply Current, I_+	$V_{\text{EN}} = 5.0\text{V}$, $V_{\text{A}} = 0\text{V}$		-3.2	-	4.5	mA	
Negative Supply Current, I_-			-3.2	-	4.5	mA	
Positive Standby Supply Current, I_+	$V_{\text{EN}} = 0\text{V}$, $V_{\text{A}} = 0\text{V}$		-3.2	-	4.5	mA	
Negative Standby Supply Current, I_-			-3.2	-	4.5	mA	

NOTES:

3. Typical values are for design aid only, not guaranteed and not subject to production testing.
4. The algebraic convention whereby the most negative value is a minimum, and the most positive value is a maximum, is used in this data sheet.
5. Off isolation = $20\text{Log } |V_{\text{S}}|/|V_{\text{D}}|$, where V_{S} = input to Off switch, and V_{D} = output due to V_{S} .
6. $I_{\text{D(ON)}}$ is leakage from driver into "ON" switch.
7. Parameter not tested. Parameter guaranteed by design or characterization.

Test Circuits and Waveforms

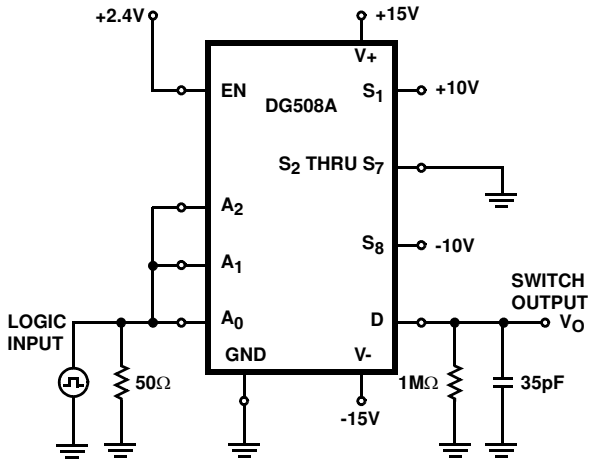

FIGURE 1A. TEST CIRCUIT

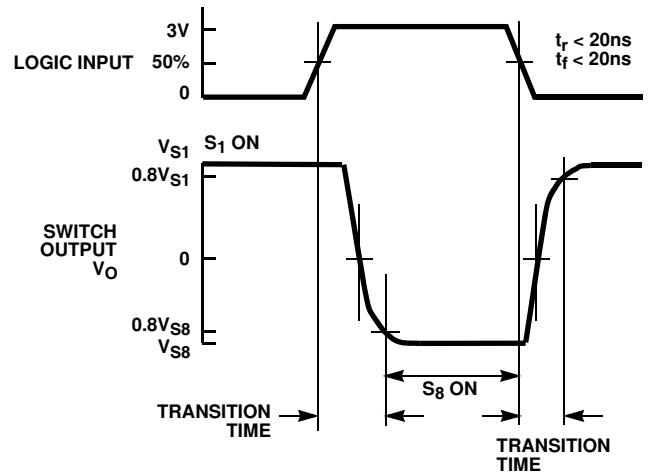

FIGURE 1B. MEASUREMENT POINTS

FIGURE 1. SWITCHING TIME

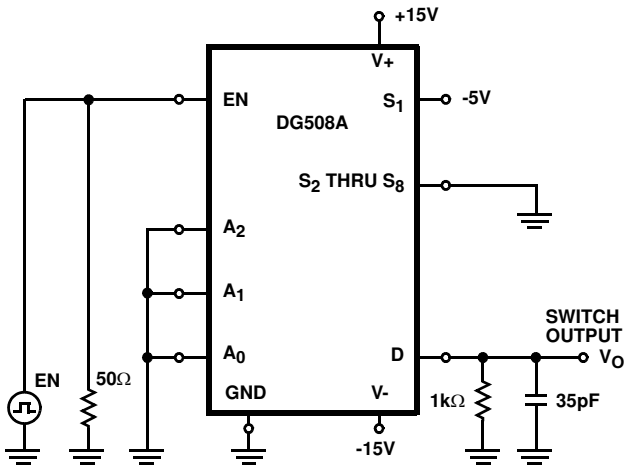

FIGURE 2A. TEST CIRCUIT

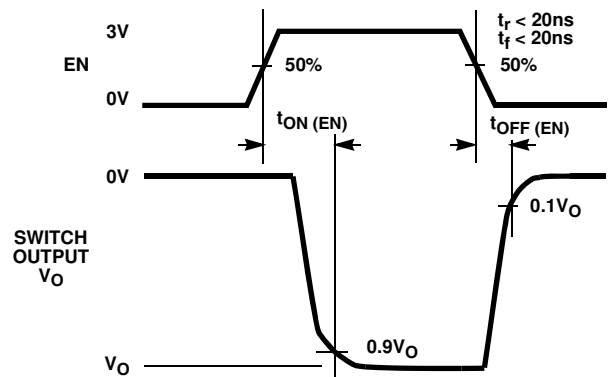

FIGURE 2B. MEASUREMENT POINTS

FIGURE 2. ENABLE TIMES

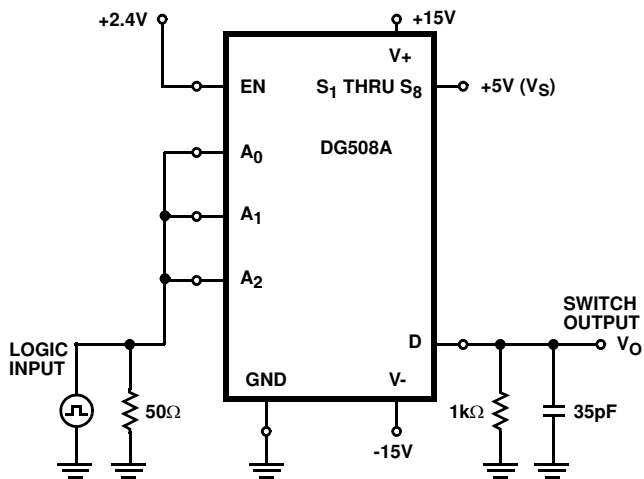

FIGURE 3A. TEST CIRCUIT

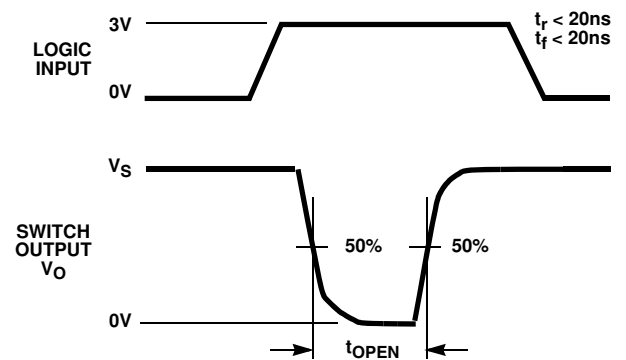

FIGURE 3B. MEASUREMENT POINTS

FIGURE 3. BREAK-BEFORE-MAKE INTERVAL

Test Circuits and Waveforms (Continued)

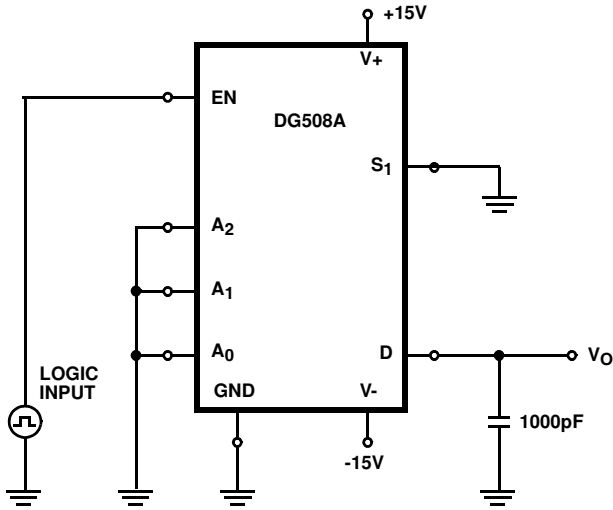
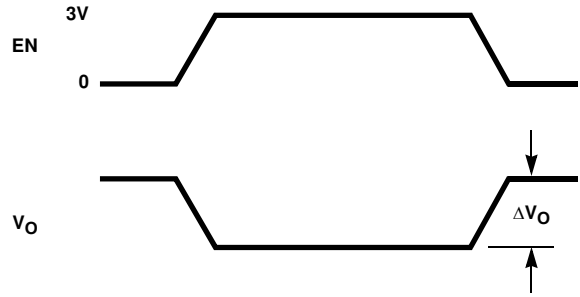

FIGURE 4A. TEST CIRCUIT



ΔV_O is the measured voltage error due to charge injection. The charge transfer error in Coulombs is $Q = C_L \times \Delta V_O$.

FIGURE 4B. CHARGE INJECTION WAVEFORMS

FIGURE 4. CHARGE INJECTION

Typical Performance Curves

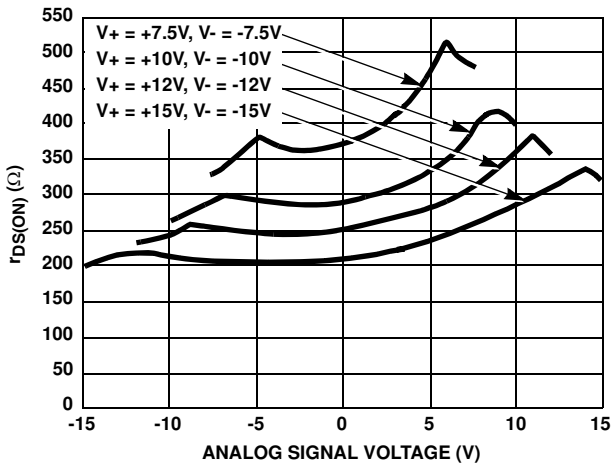

FIGURE 5. $r_{DS(ON)}$ vs ANALOG SIGNAL VOLTAGE vs SUPPLY VOLTAGE

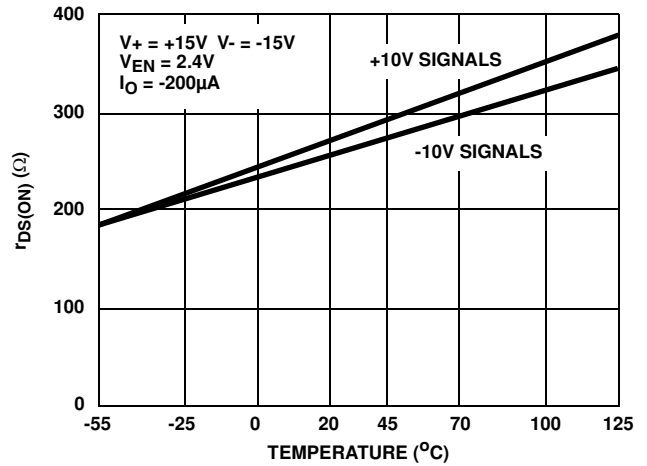

FIGURE 6. TYPICAL $r_{DS(ON)}$ VARIATION WITH TEMPERATURE

DG508A

Die Characteristics

DIE DIMENSIONS:

3100 μ m x 2083 μ m

METALLIZATION:

Type: Al

Thickness: 10k \AA \pm 1k \AA

PASSIVATION:

Type: PSG/Nitride

Thickness: PSG: 7k \AA \pm 1.4k \AA

Nitride: 8k \AA \pm 1.2k \AA

WORST CASE CURRENT DENSITY:

9.1 x 10⁴ A/cm²

Metallization Mask Layout

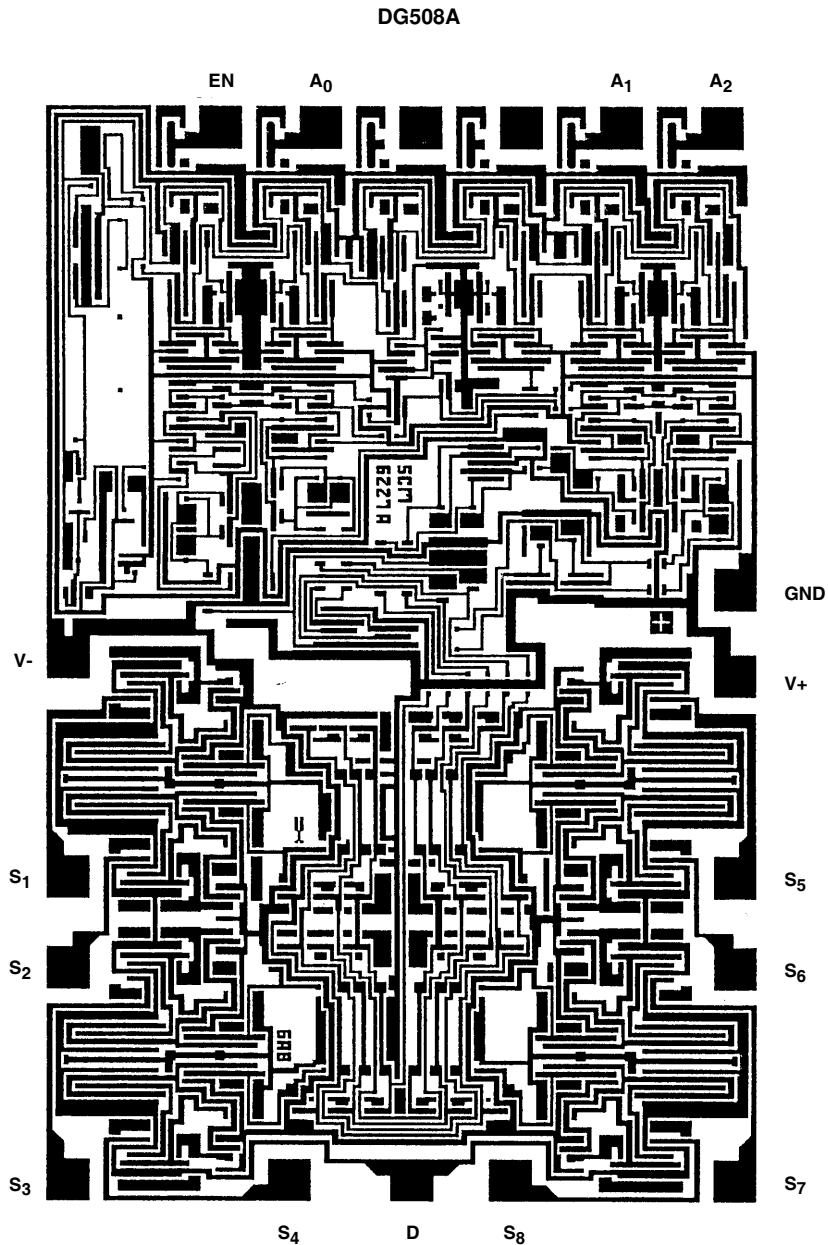

Dual-In-Line Plastic Packages (PDIP)

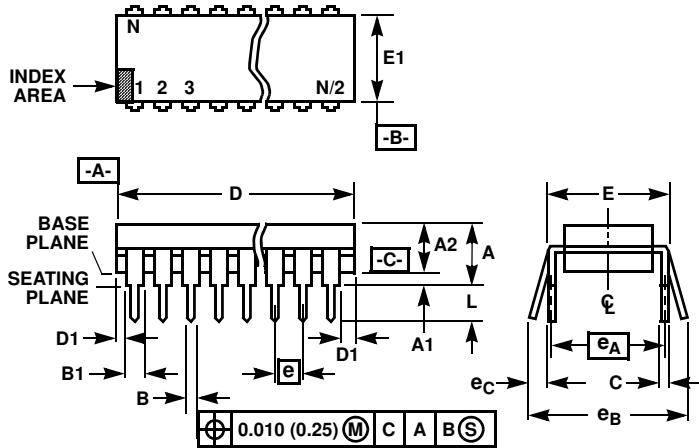

NOTES:

- Controlling Dimensions: INCH. In case of conflict between English and Metric dimensions, the inch dimensions control.
- Dimensioning and tolerancing per ANSI Y14.5M-1982.
- Symbols are defined in the "MO Series Symbol List" in Section 2.2 of Publication No. 95.
- Dimensions A, A1 and L are measured with the package seated in JEDEC seating plane gauge GS-3.
- D, D1, and E1 dimensions do not include mold flash or protrusions. Mold flash or protrusions shall not exceed 0.010 inch (0.25mm).
- E and e_A are measured with the leads constrained to be perpendicular to datum $-C-$.
- e_B and e_C are measured at the lead tips with the leads unconstrained. e_C must be zero or greater.
- B1 maximum dimensions do not include dambar protrusions. Dambar protrusions shall not exceed 0.010 inch (0.25mm).
- N is the maximum number of terminal positions.
- Corner leads (1, N, N/2 and N/2 + 1) for E8.3, E16.3, E18.3, E28.3, E42.6 will have a B1 dimension of 0.030 - 0.045 inch (0.76 - 1.14mm).

E16.3 (JEDEC MS-001-BB ISSUE D)
16 LEAD DUAL-IN-LINE PLASTIC PACKAGE

SYMBOL	INCHES		MILLIMETERS		NOTES
	MIN	MAX	MIN	MAX	
A	-	0.210	-	5.33	4
A1	0.015	-	0.39	-	4
A2	0.115	0.195	2.93	4.95	-
B	0.014	0.022	0.356	0.558	-
B1	0.045	0.070	1.15	1.77	8, 10
C	0.008	0.014	0.204	0.355	-
D	0.735	0.775	18.66	19.68	5
D1	0.005	-	0.13	-	5
E	0.300	0.325	7.62	8.25	6
E1	0.240	0.280	6.10	7.11	5
e	0.100 BSC		2.54 BSC		-
e_A	0.300 BSC		7.62 BSC		6
e_B	-	0.430	-	10.92	7
L	0.115	0.150	2.93	3.81	4
N	16		16		9

Rev. 0 12/93

Ceramic Dual-In-Line Frit Seal Packages (CERDIP)

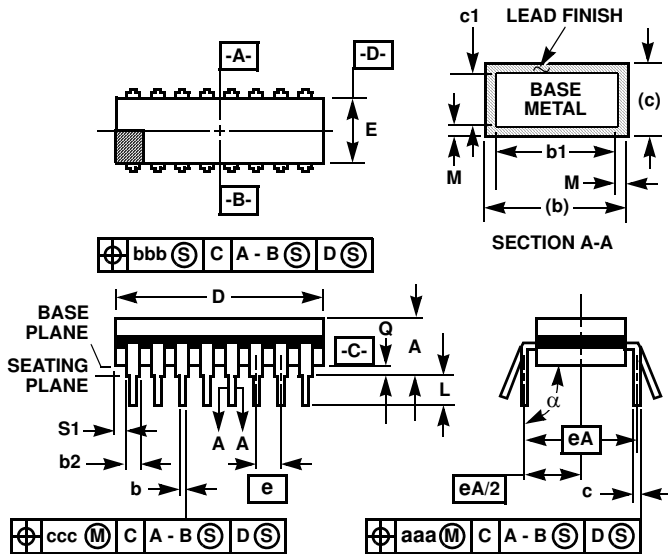

NOTES:

1. Index area: A notch or a pin one identification mark shall be located adjacent to pin one and shall be located within the shaded area shown. The manufacturer's identification shall not be used as a pin one identification mark.
2. The maximum limits of lead dimensions b and c or M shall be measured at the centroid of the finished lead surfaces, when solder dip or tin plate lead finish is applied.
3. Dimensions b1 and c1 apply to lead base metal only. Dimension M applies to lead plating and finish thickness.
4. Corner leads (1, N, N/2, and N/2+1) may be configured with a partial lead paddle. For this configuration dimension b3 replaces dimension b2.
5. This dimension allows for off-center lid, meniscus, and glass overrun.
6. Dimension Q shall be measured from the seating plane to the base plane.
7. Measure dimension S1 at all four corners.
8. N is the maximum number of terminal positions.
9. Dimensioning and tolerancing per ANSI Y14.5M - 1982.
10. Controlling dimension: INCH.

**F16.3 MIL-STD-1835 GDIP1-T16 (D-2, CONFIGURATION A)
16 LEAD CERAMIC DUAL-IN-LINE FRIT SEAL PACKAGE**

SYMBOL	INCHES		MILLIMETERS		NOTES
	MIN	MAX	MIN	MAX	
A	-	0.200	-	5.08	-
b	0.014	0.026	0.36	0.66	2
b1	0.014	0.023	0.36	0.58	3
b2	0.045	0.065	1.14	1.65	-
b3	0.023	0.045	0.58	1.14	4
c	0.008	0.018	0.20	0.46	2
c1	0.008	0.015	0.20	0.38	3
D	-	0.840	-	21.34	5
E	0.220	0.310	5.59	7.87	5
e	0.100 BSC		2.54 BSC		-
eA	0.300 BSC		7.62 BSC		-
eA/2	0.150 BSC		3.81 BSC		-
L	0.125	0.200	3.18	5.08	-
Q	0.015	0.060	0.38	1.52	6
S1	0.005	-	0.13	-	7
alpha	90°	105°	90°	105°	-
aaa	-	0.015	-	0.38	-
bbb	-	0.030	-	0.76	-
ccc	-	0.010	-	0.25	-
M	-	0.0015	-	0.038	2, 3
N	16		16		8

Rev. 0 4/94

All Intersil U.S. products are manufactured, assembled and tested utilizing ISO9000 quality systems. Intersil Corporation's quality certifications can be viewed at www.intersil.com/design/quality

Intersil products are sold by description only. Intersil Corporation reserves the right to make changes in circuit design, software and/or specifications at any time without notice. Accordingly, the reader is cautioned to verify that data sheets are current before placing orders. Information furnished by Intersil is believed to be accurate and reliable. However, no responsibility is assumed by Intersil or its subsidiaries for its use; nor for any infringements of patents or other rights of third parties which may result from its use. No license is granted by implication or otherwise under any patent or patent rights of Intersil or its subsidiaries.

For information regarding Intersil Corporation and its products, see www.intersil.com