



Chipsmall Limited consists of a professional team with an average of over 10 year of expertise in the distribution of electronic components. Based in Hongkong, we have already established firm and mutual-benefit business relationships with customers from,Europe,America and south Asia,supplying obsolete and hard-to-find components to meet their specific needs.

With the principle of “Quality Parts,Customers Priority,Honest Operation,and Considerate Service”,our business mainly focus on the distribution of electronic components. Line cards we deal with include Microchip,ALPS,ROHM,Xilinx,Pulse,ON,Everlight and Freescale. Main products comprise IC,Modules,Potentiometer,IC Socket,Relay,Connector.Our parts cover such applications as commercial,industrial, and automotives areas.

We are looking forward to setting up business relationship with you and hope to provide you with the best service and solution. Let us make a better world for our industry!



## Contact us

Tel: +86-755-8981 8866 Fax: +86-755-8427 6832

Email & Skype: info@chipsmall.com Web: www.chipsmall.com

Address: A1208, Overseas Decoration Building, #122 Zhenhua RD., Futian, Shenzhen, China







# Delta Electronics Corp.

REV.	Description	Drawn	Checked	Approved	Issue Date
00	ISSUE SPEC	Sheila Hu 7/13'12	Charles Chen 7/13'12	Charles Chen 7/13'12	
Description: SAMPLE REVISION CODE LIST					
Part No.					REV
DELTA MODEL : DHS-B9292-04A			TOTAL 10 PAGE		00



**Delta Electronics Corp.**

# CONTENTS

<b>Item</b>	<b>Element Description</b>	<b>Page</b>	<b>Note</b>
1	Specification	4	
2	Print	5	
3	Packing Plan	8	
4			



# Delta Electronics Corp.

## 1. SPECIFICATION

### 1.1 Characters

Item	Description
Scope	THIS SPECIFICATION DEFINES THE ELECTRICAL AND MECHANICAL CHARACTERISTICS OF THE HEATSINK
Application	INTEL LGA2011 CPU HEATSINK
Specification	
a: Thermal Resistance	0.24 (°C/W)(REF.)
b: total weight	430 g (REF.)
c: clip force	29.5 Kgf (REF.)

### 1.2 BOM

Item	Part Name	Material	Part NO.	Q'TY	Remark
1	FIN	AL 1050	3346397700	1PCE	
2	CU BASE	CU 1100	3346845100	1PCE	
3	CAP	SUS 304	3462395200	4PCE	
4	SCREW	SUS 304	3105359900	4PCE	
5	SPRING	ASTM A228	3462028800	4PCE	
6	E CLIP	SK7	3110264700	4PCE	
7	SPACER	POM	3244747000	4PCE	
8	GREASE	TC-1996	4021101500	0.308 g	
9	EPE	EPE	3501524000	1PCE	
10	BOX	PAPER	3518132100	1PCE	
11	TRAY	PET	3503125100	1PCE	
12	PAD PAPER	PAPER	3516261800	0.156PCE	
13	CARTON	PAPER	3513701700	0.031PCE	
14	DATECODE	POLYESTER	3265081000	1PCE	
15	LABEL	PAPER	3261447400	0.031PCE	



**Delta Electronics Corp.**

## **2. PRINT**

### **2.1 Assembly Drawing**



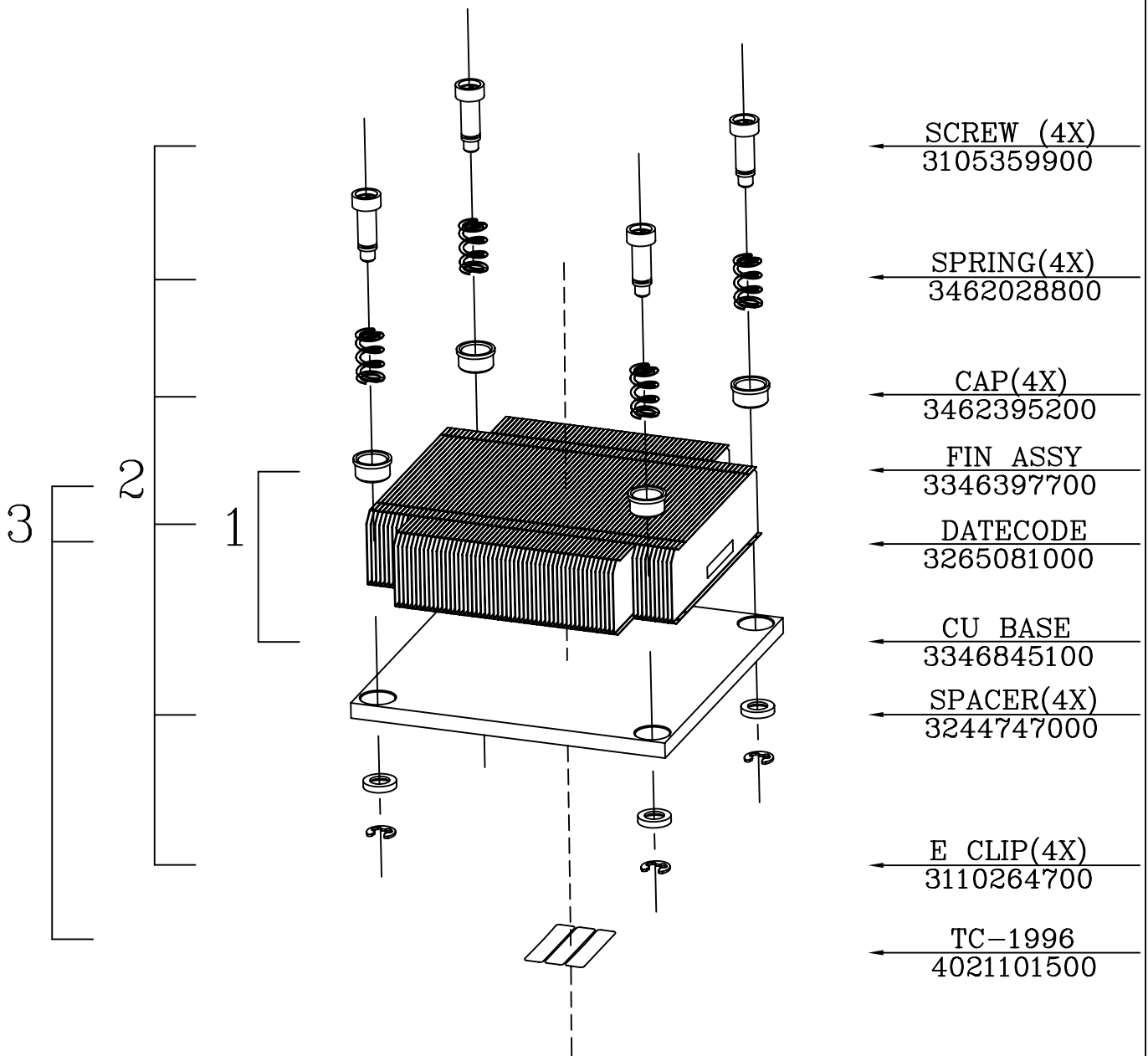

SCREW (4X)  
3105359900

SPRING(4X)  
3462028800

CAP(4X)  
3462395200

FIN ASSY  
3346397700

DATECODE  
3265081000

CU BASE  
3346845100

SPACER(4X)  
3244747000

E CLIP(4X)  
3110264700

TC-1996  
4021101500



台達電子工業股份有限公司  
DELTA ELECTRONICS, INC.

DELTA MODEL:  
DHS-B9292-04A

Drawn:  
SHEILA

THESE DRAWINGS AND SPECIFICATIONS ARE THE PROPERTY OF DELTA ELECTRONICS, INC. AND SHALL NOT BE REPRODUCED OR USED AS THE BASIS FOR THE MANUFACTURE OR SELL OF APPARATUSES OR DEVICES WITHOUT PERMISSION.

CUSTOMER NAME: STD

CUSTOMER P/N: ---

DIMENSIONAL TOLERANCES		HOLES : ±0.05		ANGLES : ±0.5°	
( )	( )	( )	( )	( )	( )
<30	±0.25	DECIMALS	UP~100 : ±0.2	250~300 : ±0.4	UP~600 : ±1.5
>30~100	±0.35	X : ±0.3	100~150 : ±0.25	300~350 : ±0.45	600~900 : ±2.4
>100~300	±0.5	XX : ±0.2	150~200 : ±0.3	350~400 : ±0.5	900~OVER : ±3.1
ABOVE 300	±0.6	XXX : ±0.1	200~250 : ±0.35		



Description: PRODUCTION SPEC.  
(ASSEMBLY ORDER)

A4  
SIZE

Part No. DHS-B9292-04A-AS

REV.

SHEET 1 OF 1 ISSUE DATE:

---

SCALE --- UNIT --- USED ON COOLER

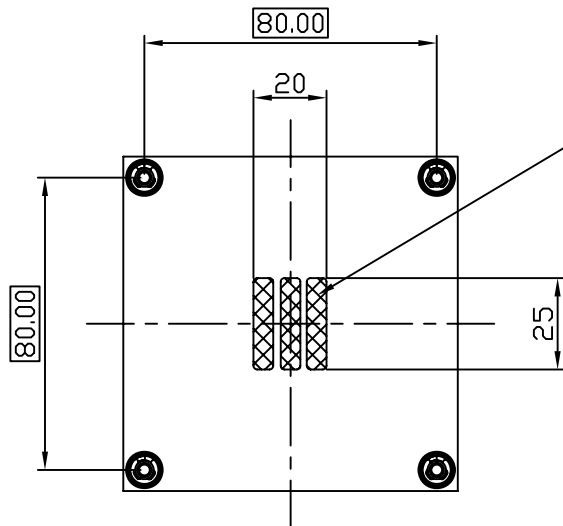
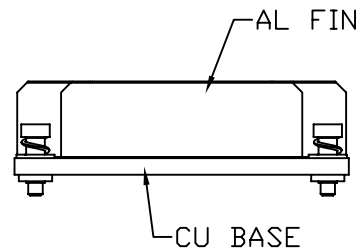
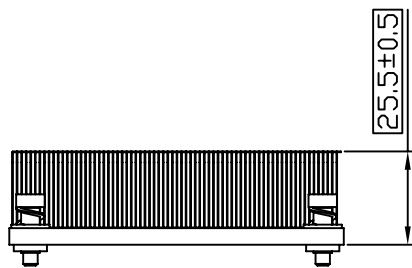
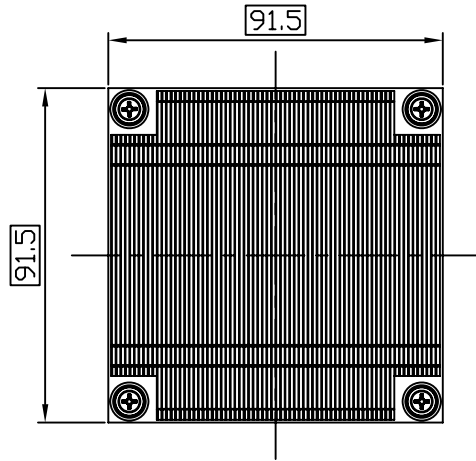

Dow Corning TC-1996 P/N:4021101500

\*STENCIL THICKNESS=0.20(TYP.) 0.22(MAX.)  
TIM WEIGHT ON HSK MUST BE 250mg±30mg



**台達電子工業股份有限公司**  
**DELTA ELECTRONICS, INC.**

DELTA MODEL:  
DHS-B9292-04A

Drawn:  
SHEILA

THESE DRAWINGS AND SPECIFICATIONS ARE THE PROPERTY OF DELTA ELECTRONICS, INC. AND SHALL NOT BE REPRODUCED OR USED AS THE BASIS FOR THE MANUFACTURE OR SELL OF APPARATUSES OR DEVICES WITHOUT PERMISSION.

CUSTOMER NAME: STD

CUSTOMER P/N: ---

DIMENSIONAL TOLERANCES		HOLES : ±0.05		ANGLES : ±0.5°	
( )	(✓)	( )	( )	( )	( )
<30	±0.25	DECIMALS	UP~100 :±0.2	250~300	UP~600
>30~100	±0.35	X :±1.0	100~150 :±0.25	300~350 :±0.1	600~900
>100~300	±0.5	X.X :±0.4	150~200 :±0.3	350~400 :±0.5	900~OVER
ABOVE 300	±0.6	X.XX:±0.2	200~250:±0.35		



Description: PRODUCTION SPEC.  
(PHYSICAL DIMENSION)

A4  
SIZE

Part No. DHS-B9292-04A-PD

REV.

---

SCALE --- UNIT mm USED ON COOLER

SHEET 1 OF 1 ISSUE DATE:





**Delta Electronics Corp.**

### **3. Packing Plan**

PART NO.	DHS-B9292-04A			
BASIC DATA	QUANTITY/CARTON	32 PCS		
	PRODUCTION NET WEIGHT	13.2 Kg (REF)		
	PRODUCTION GROSS WEIGHT	14.5 Kg (REF)		
20(ft)CONTAINER ILLUSTRATE	SIZE	5.889(L)*2.352(w)*2.386(H)m	PACKING QUANTITY	20 PALLETS/CONTAINER
	CONTAINER	STEEL		

CONTAINER FORM

CONTAINER LOADING METHOD

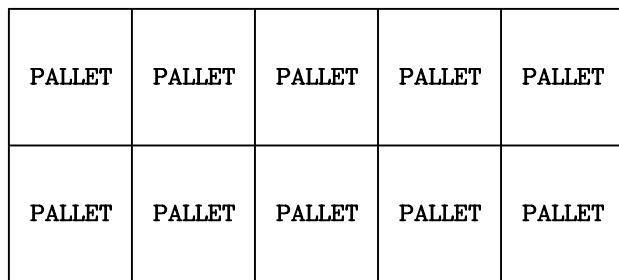

TOP VIEW

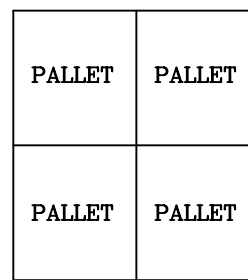

FRONT VIEW

PALLET LOADING ILLUSTRATE	SIZE	120(L)*100(w)*13.5(H)cm	PACKING QUANTITY	24 CARTONS/PALLET
	PALLET	WOOD		

PALLET ILLUSTRATE  
PALLET LOADING METHOD

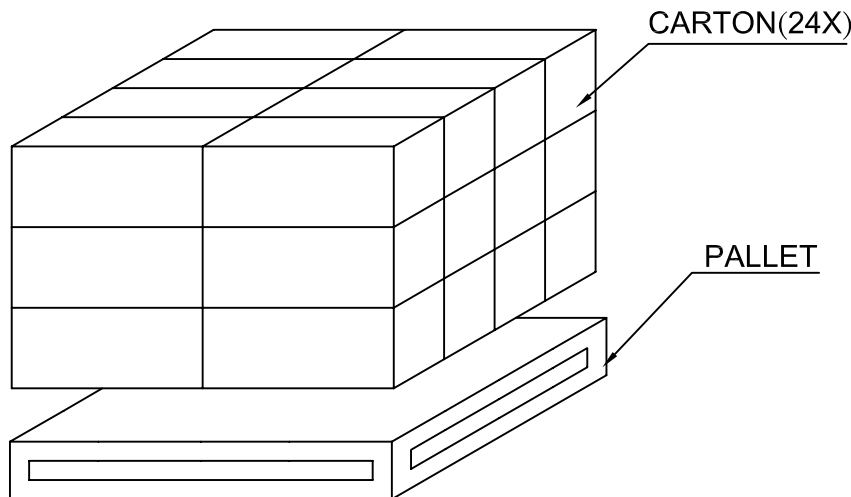

台達電子工業股份有限公司  
DELTA ELECTRONICS, INC.

DELTA MODEL: DHS-B9292-04A	Drawn: SHEILA
-------------------------------	------------------

THESE DRAWINGS AND SPECIFICATIONS ARE THE PROPERTY OF DELTA ELECTRONICS, INC. AND SHALL NOT BE REPRODUCED OR USED AS THE BASIS FOR THE MANUFACTURE OR SELL OF APPARATUSES OR DEVICES WITHOUT PERMISSION.

CUSTOMER NAME:	STD
CUSTOMER P/N:	---

DIMENSIONAL TOLERANCES		HOLES : ±0.05		ANGLES : ±0.5°	
( )	( )	( )	( )	( )	( )
<30	±0.25	DECIMALS	UP-100	±0.2	250-300
>30-100	±0.35	X	100-150	±0.25	300-350
>100-300	±0.5	XX	150-200	±0.3	350-400
ABOVE 300	±0.6	X.XX	200-250	±0.35	900-OVER
					±0.4
					±0.45
					±0.5
					±1.5
					±2.4
					±3.1

 THIRD ANGLE PROJECTION  <b>A4</b> SIZE	Description:	PRODUCTION SPEC. (PACKING ASSEMBLY)
	Part No.	DHS-B9292-04A-PA

SCALE	---	UNIT	---	USED ON	COOLER
SHEET 1 OF 2					ISSUE DATE:
					REV.
					--

CARTON ILLUSTRATE	SIZE	516(L)*236(w)*242(H)(mm)	PACKING QUANTITY	4 LAYERS/CARTON
	MATERIAL	5 LAYERS"AB" FLUTE	CARTON WEIGHT	0.9 kg (REF.)

CARTON OUTSIDE DEMONSTRATE

FRONT

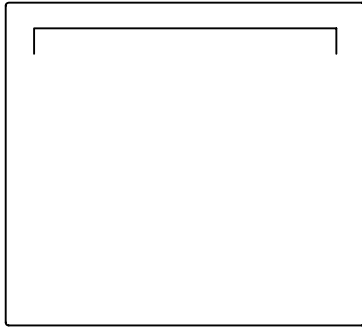

BACK

RoHS Compliant	CE
CUSTOMER PART NO.	
DELTA PART NO.	
QUANTITY	
P/O NO.	
DATE CODE	
GROSS WEIGHT	

BOX PACKING ILLUSTRATE	SIZE	126(L)*100(w)*50(H)(mm)	PACKING QUANTITY	1 PCS/BOX
	MATERIAL	PAPER	MATERIAL WEIGHT	40g (REF.)

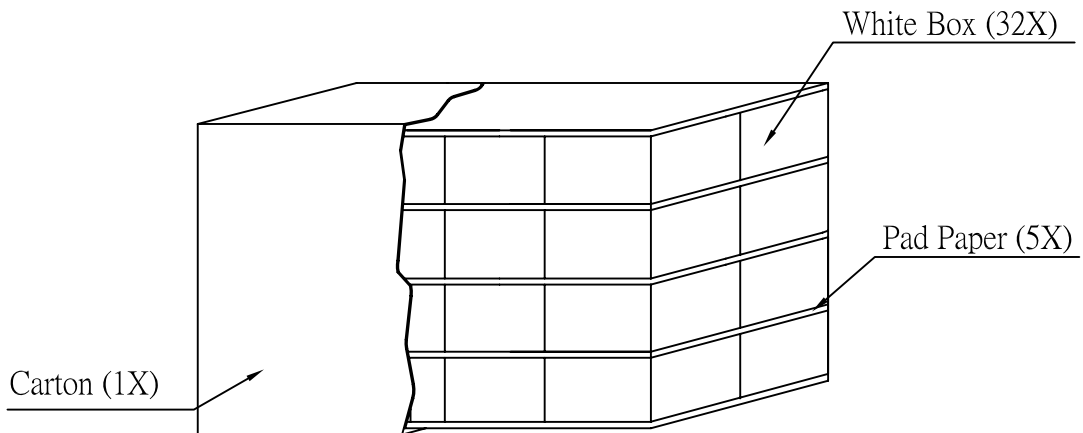

台達電子工業股份有限公司  
DELTA ELECTRONICS, INC.

DELTA MODEL:  
DHS-B9292-04A

Drawn:  
SHEILA

THESE DRAWINGS AND SPECIFICATIONS ARE THE PROPERTY OF DELTA ELECTRONICS, INC. AND SHALL NOT BE REPRODUCED OR USED AS THE BASIS FOR THE MANUFACTURE OR SELL OF APPARATUSES OR DEVICES WITHOUT PERMISSION.

CUSTOMER NAME: STD

CUSTOMER P/N: ---

DIMENSIONAL TOLERANCES		HOLES : ±0.05		ANGLES : ±0.5°				
( )	( )	( )	( )	( )	( )			
<30	±0.25	DECIMALS	UP~100	±0.2	250~300	±0.4	UP~600	±1.5
>30~100	±0.35	X	100~150	±0.25	300~350	±0.45	600~900	±2.4
>100~300	±0.5	XX	150~200	±0.3	350~400	±0.5	900-OVER	±3.1
ABOVE 300	±0.6	X.XX	200~250	±0.35				



Description: PRODUCTION SPEC.  
(PACKING ASSEMBLY)

A4

Part No. DHS-B9292-04A-PA

REV.

SIZE

SHEET 2 OF 2

ISSUE DATE:

--

SCALE --- UNIT --- USED ON COOLER