



Chipsmall Limited consists of a professional team with an average of over 10 year of expertise in the distribution of electronic components. Based in Hongkong, we have already established firm and mutual-benefit business relationships with customers from,Europe,America and south Asia,supplying obsolete and hard-to-find components to meet their specific needs.

With the principle of “Quality Parts,Customers Priority,Honest Operation,and Considerate Service”,our business mainly focus on the distribution of electronic components. Line cards we deal with include Microchip,ALPS,ROHM,Xilinx,Pulse,ON,Everlight and Freescale. Main products comprise IC,Modules,Potentiometer,IC Socket,Relay,Connector.Our parts cover such applications as commercial,industrial, and automotives areas.

We are looking forward to setting up business relationship with you and hope to provide you with the best service and solution. Let us make a better world for our industry!



## Contact us

Tel: +86-755-8981 8866 Fax: +86-755-8427 6832

Email & Skype: info@chipsmall.com Web: www.chipsmall.com

Address: A1208, Overseas Decoration Building, #122 Zhenhua RD., Futian, Shenzhen, China



# DHS50A

DH S 50 A 05 -□

① ② ③ ④ ⑤ ⑥

\*Providing heat sink as option

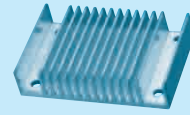

- ① Series name
- ② Single output
- ③ Output wattage
- ④ A : DC60-160V
- ⑤ Output voltage
- ⑥ Optional
- T : with Mounting hole (φ 3.4 thru)

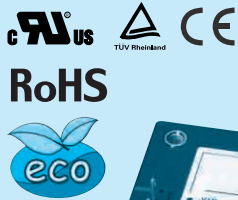

MODEL	DHS50A05	DHS50A12	DHS50A15	DHS50A24
MAX OUTPUT WATTAGE[W]	50.0	50.4	51.0	50.4
DC OUTPUT	5V 10A	12V 4.2A	15V 3.4A	24V 2.1A

## SPECIFICATIONS

	MODEL	DHS50A05	DHS50A12	DHS50A15	DHS50A24	
INPUT	VOLTAGE[V]	DC60 - 160				
	CURRENT[A]	0.55A	0.55A	0.55A	0.55A	
	EFFICIENCY[%]	84.0typ	86.0typ	86.0typ	86.0typ	
		*1				
OUTPUT	VOLTAGE[V]	5	12	15	24	
	CURRENT[A]	10	4.2	3.4	2.1	
	LINE REGULATION[mV]	10max	24max	30max	48max	
	LOAD REGULATION[mV]	10max	24max	30max	48max	
	RIPPLE[mVp-p]	0 to +100°C *2	80max	120max	120max	120max
		-40 to 0°C *2	120max	150max	150max	150max
		0 to 15% Load *2	160max	240max	240max	240max
	RIPPLE NOISE[mVp-p]	0 to +100°C *2	120max	150max	150max	150max
		-40 to 0°C *2	200max	200max	200max	250max
		0 to 15% Load *2	240max	300max	300max	300max
	TEMPERATURE REGULATION[mV]	0 to +65°C	50max	120max	150max	240max
		-40 to +100°C	100max	240max	300max	480max
	DRIFT[mV]	*3	20max	40max	60max	90max
	START-UP TIME[ms]	200max (DCIN 110V, Io=100%)				
OUTPUT VOLTAGE ADJUSTMENT RANGE[V]	*4	Fixed (TRM pin open), adjustable by external VR or external voltage				
		4.50 - 6.00	10.80 - 13.20	13.50 - 16.50	21.60 - 26.40	
OUTPUT VOLTAGE SETTING[V]		4.97 - 5.13	11.91 - 12.29	14.76 - 15.24	23.62 - 24.38	
PROTECTION CIRCUIT AND OTHERS	OVERCURRENT PROTECTION	Works over 105% of rating and recovers automatically				
	OVERVOLTAGE PROTECTION[V]	6.30 - 7.60	13.90 - 17.55	17.25 - 21.75	27.60 - 34.80	
	REMOTE SENSING	nothing				
	REMOTE ON/OFF	Provided (Negative Logic L : ON, H :OFF)				
ISOLATION	INPUT-OUTPUT	AC3,000V 1minute, Cutoff current = 10mA, DC500V 50MΩ min (20±15°C)				
	INPUT-FG	AC2,000V 1minute, Cutoff current = 10mA, DC500V 50MΩ min (20±15°C)				
	OUTPUT-FG	AC500V 1minute, Cutoff current = 100mA, DC500V 50MΩ min (20±15°C)				
ENVIRONMENT	OPERATING TEMP., HUMID. AND ALTITUDE	-40 to +100°C (On aluminum base plate), 20 - 95%RH (Non condensing) (Refer to DERATING CURVE), 3,000m (10,000 feet) max				
	STORAGE TEMP., HUMID. AND ALTITUDE	-40 to +100°C, 20 - 95%RH (Non condensing), 9,000m (30,000 feet) max				
	VIBRATION	10 - 55Hz, 49.0m/s <sup>2</sup> (5G), 3minutes period, 60minutes each along X, Y and Z axis Complies with IEC61373 Category 1 Class B				
	IMPACT	196.1m/s <sup>2</sup> (20G), 11ms, once each along X, Y and Z axis Complies with IEC61373 Category 1 Class B				
SAFETY	AGENCY APPROVALS	UL60950-1, C-UL (CSA60950-1), EN60950-1				
OTHERS	CASE SIZE/WEIGHT	58.4 × 12.7 × 37.3mm [2.3 × 0.5 × 1.47 inches] (W × H × D) / 60g max				
	COOLING METHOD	Conduction cooling (e.g. heat radiation from the aluminum base plate to the attached heat sink)				

\*1 At rated input(DC110V) and rated load.  
 \*2 Ripple and ripple noise is measured by using measuring board. Refer to the manual  
 \*3 Drift is the change in DC output for an eight hour period after a half-hour warm-up at 25°C, with the input voltage held constant at the rated input/output.  
 \*4 Refer to the manual for input range.

External view

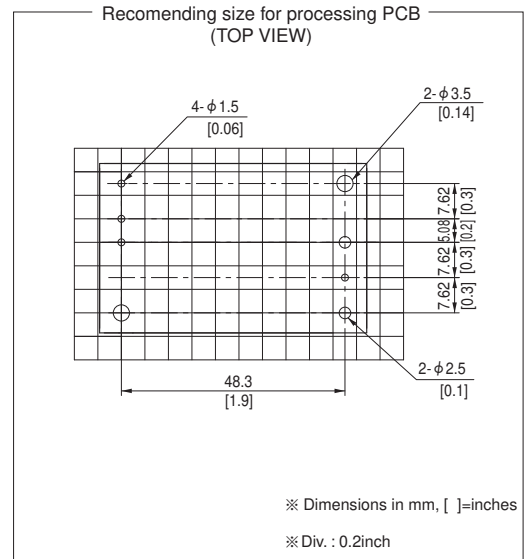
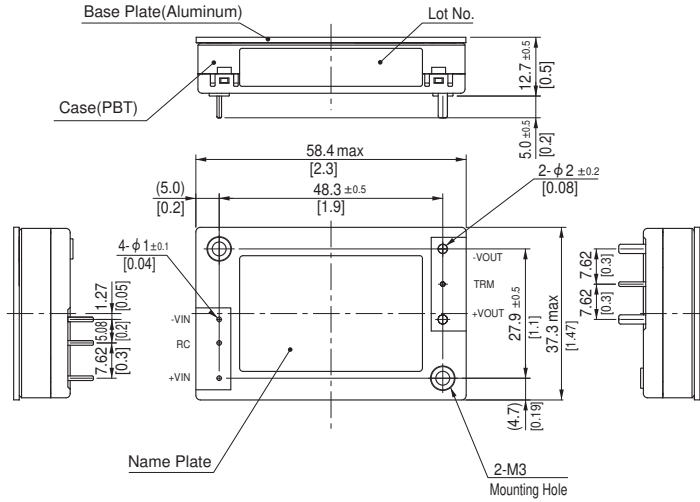

※ Dimensions in mm, [ ]=inches  
 ※ Div. : 0.2inch

- ※ Tolerance : ±0.3 [±0.012]
- ※ Weight : 60g max
- ※ Dimensions in mm, [ ]=inches
- ※ Mounting hole screwing torque : 0.49N · m (5.0kgf · cm) max



# DHS100A

DH S 100 A 05 -□

① ② ③ ④ ⑤ ⑥

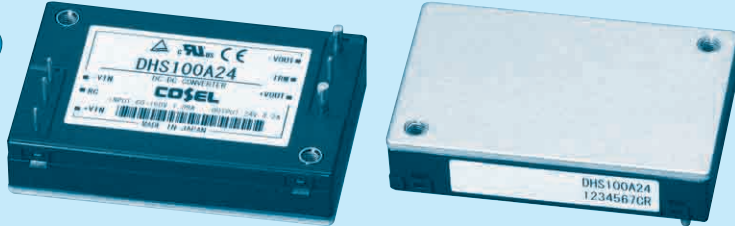

\*Providing heat sink as option

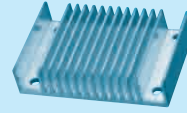

- ① Series name
- ② Single output
- ③ Output wattage
- ④ A : DC60-160V
- ⑤ Output voltage
- ⑥ Optional
- T : with Mounting hole (φ 3.4 thru)

MODEL	DHS100A05	DHS100A12	DHS100A15	DHS100A24
MAX OUTPUT WATTAGE[W]	100.0	100.8	100.5	100.8
DC OUTPUT	5V 20A	12V 8.4A	15V 6.7A	24V 4.2A

## SPECIFICATIONS

	MODEL	DHS100A05	DHS100A12	DHS100A15	DHS100A24	
INPUT	VOLTAGE[V]	DC60 - 160				
	CURRENT[A]	1.1A	1.1A	1.1A	1.1A	
	EFFICIENCY[%]	85.0typ	88.0typ	88.0typ	88.0typ	
OUTPUT	VOLTAGE[V]	5	12	15	24	
	CURRENT[A]	20	8.4	6.7	4.2	
	LINE REGULATION[mV]	10max	24max	30max	48max	
	LOAD REGULATION[mV]	10max	24max	30max	48max	
	RIPPLE[mVp-p]	0 to +100°C *2	80max	120max	120max	120max
		-40 to 0°C *2	120max	150max	150max	150max
		0 to 15% Load *2	160max	240max	240max	240max
	RIPPLE NOISE[mVp-p]	0 to +100°C *2	120max	150max	150max	150max
		-40 to 0°C *2	200max	200max	200max	250max
		0 to 15% Load *2	240max	300max	300max	300max
	TEMPERATURE REGULATION[mV]	0 to +65°C	50max	120max	150max	240max
		-40 to +100°C	100max	240max	300max	480max
	DRIFT[mV]	*3	20max	40max	60max	90max
START-UP TIME[ms]	200max (DCIN 110V, Io=100%)					
OUTPUT VOLTAGE ADJUSTMENT RANGE[V]	*4	Fixed (TRM pin open), adjustable by external VR or external voltage				
		4.50 - 6.00	10.80 - 13.20	13.50 - 16.50	21.60 - 26.40	
		4.97 - 5.13	11.91 - 12.29	14.76 - 15.24	23.62 - 24.38	
PROTECTION CIRCUIT AND OTHERS	OVERCURRENT PROTECTION	Works over 105% of rating and recovers automatically				
	OVERVOLTAGE PROTECTION[V]	6.30 - 7.60	13.90 - 17.55	17.25 - 21.75	27.60 - 34.80	
	REMOTE SENSING	nothing				
	REMOTE ON/OFF	Provided (Neqative Logic L : ON, H :OFF)				
ISOLATION	INPUT-OUTPUT	AC3,000V 1minute, Cutoff current = 10mA, DC500V 50MΩ min (20±15°C)				
	INPUT-FG	AC2,000V 1minute, Cutoff current = 10mA, DC500V 50MΩ min (20±15°C)				
	OUTPUT-FG	AC500V 1minute, Cutoff current = 100mA, DC500V 50MΩ min (20±15°C)				
ENVIRONMENT	OPERATING TEMP.,HUMID.AND ALTIUDE	-40 to +100°C (On aluminum base plate), 20 - 95%RH (Non condensing) (Refer to DERATING CURVE), 3,000m (10,000 feet) max				
	STORAGE TEMP.,HUMID.AND ALTIUDE	-40 to +100°C, 20 - 95%RH (Non condensing), 9,000m (30,000 feet) max				
	VIBRATION	10 - 55Hz, 49.0m/s <sup>2</sup> (5G), 3minutes period, 60minutes each along X, Y and Z axis Complies with IEC61373 Category 1 Class B				
	IMPACT	196.1m/s <sup>2</sup> (20G), 11ms, once each along X, Y and Z axis Complies with IEC61373 Category 1 Class B				
SAFETY	AGENCY APPROVALS	UL60950-1, C-UL (CSA60950-1), EN60950-1				
OTHERS	CASE SIZE/WEIGHT	58.4 × 12.7 × 37.3mm [2.3 × 0.5 × 1.47 inches] (W × H × D) / 60g max				
	COOLING METHOD	Conduction cooling (e.g. heat radiation from the aluminum base plate to the attached heat sink)				

\*1 At rated input(DC110V) and rated load.  
 \*2 Ripple and ripple noise is measured by using measuring board. Refer to the manual.  
 \*3 Drift is the change in DC output for an eight hour period after a half-hour warm-up at 25°C, with the input voltage held constant at the rated input/output.  
 \*4 Refer to the manual for input range.

External view

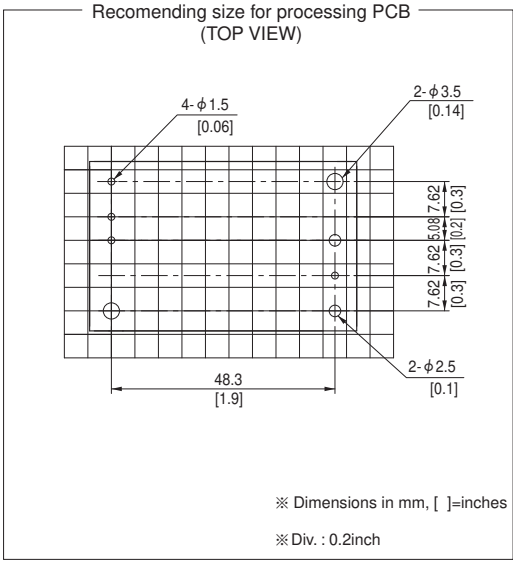
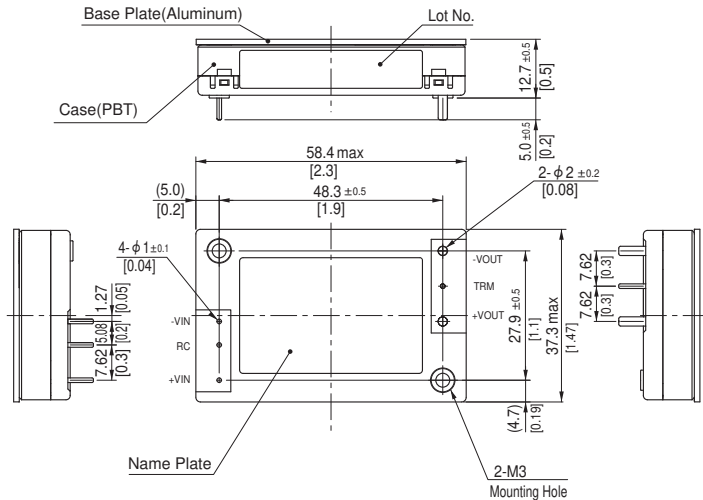

※ Dimensions in mm, [ ]=inches  
 ※ Div. : 0.2inch

- ※ Tolerance : ±0.3 [±0.012]
- ※ Weight : 60g max
- ※ Dimensions in mm, [ ]=inches
- ※ Mounting hole screwing torque : 0.49N · m (5.0kgf · cm) max

# DHS200A

DH S 200 A 05 -□

① ② ③ ④ ⑤ ⑥

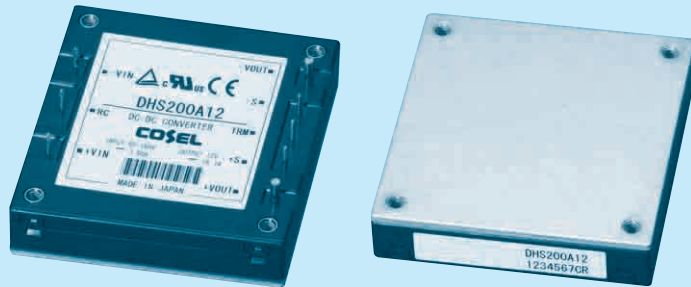

\*Providing heat sink as option

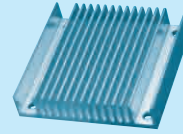

- ① Series name
- ② Single output
- ③ Output wattage
- ④ A : DC60-160V
- ⑤ Output voltage
- ⑥ Optional  
T : with Mounting hole (φ 3.4 thru)

MODEL	DHS200A05	DHS200A12	DHS200A15	DHS200A24
MAX OUTPUT WATTAGE[W]	200.0	200.4	201.0	201.6
DC OUTPUT	5V 40A	12V 16.7A	15V 13.4A	24V 8.4A

## SPECIFICATIONS

	MODEL	DHS200A05	DHS200A12	DHS200A15	DHS200A24	
INPUT	VOLTAGE[V]	DC60 - 160				
	CURRENT[A]	2.1A	2.1A	2.1A	2.1A	
	EFFICIENCY[%]	87.0typ	88.0typ	88.0typ	88.0typ	
OUTPUT	VOLTAGE[V]	5	12	15	24	
	CURRENT[A]	40	16.7	13.4	8.4	
	LINE REGULATION[mV]	10max	24max	30max	48max	
	LOAD REGULATION[mV]	10max	24max	30max	48max	
	RIPPLE[mVp-p]	0 to +100°C *2	80max	120max	120max	120max
		-40 to 0°C *2	120max	150max	150max	150max
		0 to 15% Load *2	160max	240max	240max	240max
	RIPPLE NOISE[mVp-p]	0 to +100°C *2	120max	150max	150max	150max
		-40 to 0°C *2	200max	200max	200max	250max
		0 to 15% Load *2	240max	300max	300max	300max
	TEMPERATURE REGULATION[mV]	0 to +65°C	50max	120max	150max	240max
		-40 to +100°C	100max	240max	300max	480max
	DRIFT[mV]	*3	20max	40max	60max	90max
START-UP TIME[ms]	200max (DCIN 110V, Io=100%)					
OUTPUT VOLTAGE ADJUSTMENT RANGE[V]	*4	Fixed (TRM pin open), adjustable by external VR or external voltage				
		3.00 - 6.00	7.20 - 13.20	9.00 - 16.50	14.40 - 26.40	
OUTPUT VOLTAGE SETTING[V]		4.97 - 5.13	11.91 - 12.29	14.76 - 15.24	23.62 - 24.38	
PROTECTION CIRCUIT AND OTHERS	OVERCURRENT PROTECTION	Works over 105% of rating and recovers automatically				
	OVERVOLTAGE PROTECTION[V]	6.30 - 7.30	13.90 - 16.35	17.25 - 20.25	27.60 - 32.40	
	REMOTE SENSING	Provided				
REMOTE ON/OFF	Provided (Negative Logic L : ON, H :OFF)					
ISOLATION	INPUT-OUTPUT	AC3,000V 1minute, Cutoff current = 10mA, DC500V 50MΩ min (20±15°C)				
	INPUT-FG	AC2,000V 1minute, Cutoff current = 10mA, DC500V 50MΩ min (20±15°C)				
	OUTPUT-FG	AC500V 1minute, Cutoff current = 100mA, DC500V 50MΩ min (20±15°C)				
ENVIRONMENT	OPERATING TEMP., HUMID. AND ALTITUDE	-40 to +100°C (On aluminum base plate), 20 - 95%RH (Non condensing) (Refer to DERATING CURVE), 3,000m (10,000 feet) max				
	STORAGE TEMP., HUMID. AND ALTITUDE	-40 to +100°C, 20 - 95%RH (Non condensing), 9,000m (30,000 feet) max				
	VIBRATION	10 - 55Hz, 49.0m/s <sup>2</sup> (5G), 3minutes period, 60minutes each along X, Y and Z axis Complies with IEC61373 Category 1 Class B				
	IMPACT	196.1m/s <sup>2</sup> (20G), 11ms, once each along X, Y and Z axis Complies with IEC61373 Category 1 Class B				
SAFETY	AGENCY APPROVALS	UL60950-1, C-UL (CSA60950-1), EN60950-1				
OTHERS	CASE SIZE/WEIGHT	58.4 × 12.7 × 61mm [2.3 × 0.5 × 2.4 inches] (W × H × D) / 100g max				
	COOLING METHOD	Conduction cooling (e.g. heat radiation from the aluminum base plate to the attached heat sink)				

\*1 At rated input(DC110V) and rated load.  
 \*2 Ripple and ripple noise is measured by using measuring board. Refer to the manual.  
 \*3 Drift is the change in DC output for an eight hour period after a half-hour warm-up at 25°C, with the input voltage held constant at the rated input/output.  
 \*4 Refer to the manual for input range.

External view

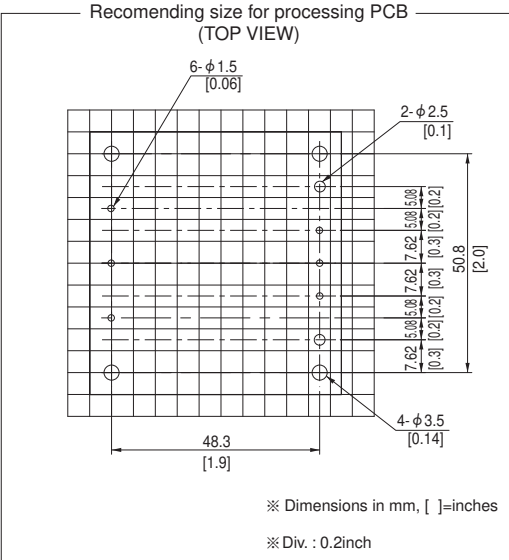
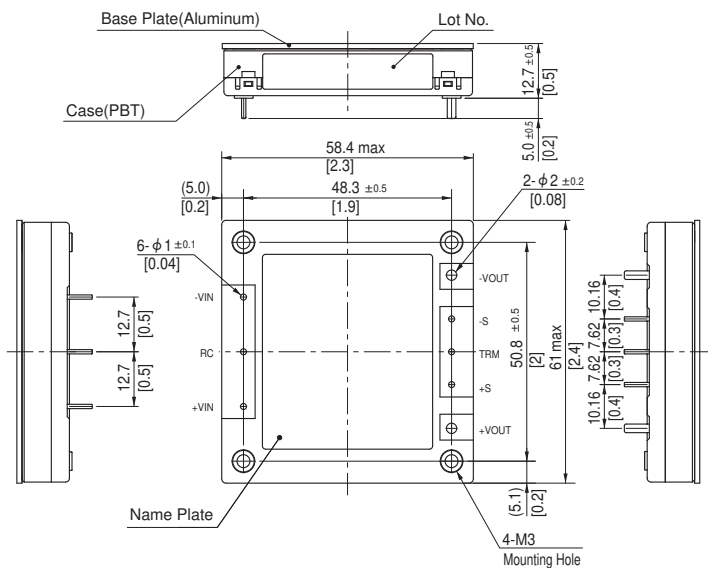

※ Dimensions in mm, [ ]=inches  
 ※ Div. : 0.2inch

- ※ Tolerance : ±0.3 [±0.012]
- ※ Weight : 100g max
- ※ Dimensions in mm, [ ]=inches
- ※ Mounting hole screwing torque : 0.49N · m (5.0kgf · cm) max

# DHS50B

DH S 50 B 05 -□

① ② ③ ④ ⑤ ⑥

\*Providing heat sink as option

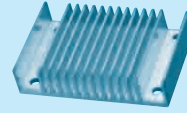

- ① Series name
- ② Single output
- ③ Output wattage
- ④ B : DC200-400V
- ⑤ Output voltage
- ⑥ Optional  
T : with Mounting hole (φ 3.4 thru)



RoHS



MODEL	DHS50B03	DHS50B05	DHS50B12	DHS50B15	DHS50B24	DHS50B28
MAX OUTPUT WATTAGE[W]	33.0	50.0	50.4	51.0	50.4	50.4
DC OUTPUT	3.3V 10A	5V 10A	12V 4.2A	15V 3.4A	24V 2.1A	28V 1.8A

## SPECIFICATIONS

	MODEL	DHS50B03	DHS50B05	DHS50B12	DHS50B15	DHS50B24	DHS50B28	
INPUT	VOLTAGE[V]	DC200 - 400						
	CURRENT[A]	0.15A	0.22A	0.22A	0.22A	0.22A	0.22A	
	EFFICIENCY[%]	77.0typ	80.0typ	83.0typ	83.0typ	83.0typ	82.0typ	
OUTPUT	VOLTAGE[V]	3.3	5	12	15	24	28	
	CURRENT[A]	10	10	4.2	3.4	2.1	1.8	
	LINE REGULATION[mV]	10max	10max	24max	30max	48max	56max	
	LOAD REGULATION[mV]	10max	10max	24max	30max	48max	56max	
	RIPPLE[mVp-p]	0 to +100°C	80max	80max	120max	120max	120max	120max
		-40 to 0°C	120max	120max	150max	150max	150max	150max
		0 to 15% Load	160max	160max	240max	240max	240max	240max
	RIPPLE NOISE[mVp-p]	0 to +100°C	120max	120max	150max	150max	150max	150max
		-40 to 0°C	200max	200max	200max	200max	250max	250max
		0 to 15% Load	240max	240max	300max	300max	300max	300max
	TEMPERATURE REGULATION[mV]	0 to +65°C	35max	50max	120max	150max	240max	280max
		-40 to +100°C	66max	100max	240max	300max	480max	560max
	DRIFT[mV]	16max	20max	40max	60max	90max	90max	
START-UP TIME[ms]	200max (DCIN 280V, Io=100%)							
OUTPUT VOLTAGE ADJUSTMENT RANGE[V]	Fixed (TRM pin open), adjustable by external VR or external voltage							
	2.97 - 3.96	4.50 - 6.00	10.80 - 13.20	13.50 - 16.50	21.60 - 26.40	25.20 - 30.80		
OUTPUT VOLTAGE SETTING[V]	3.30 - 3.40	4.97 - 5.13	11.91 - 12.29	14.76 - 15.24	23.62 - 24.38	27.56 - 28.44		
PROTECTION CIRCUIT AND OTHERS	OVERCURRENT PROTECTION	Works over 105% of rating and recovers automatically						
	OVERVOLTAGE PROTECTION[V]	4.20 - 5.70	6.30 - 7.60	13.90 - 17.55	17.25 - 21.75	27.60 - 34.80	32.20 - 40.60	
	REMOTE SENSING	None						
REMOTE ON/OFF	Provided (Negative Logic L : ON, H :OFF)							
ISOLATION	INPUT-OUTPUT	AC3,000V 1minute, Cutoff current = 10mA, DC500V 50MΩ min (20±15°C)						
	INPUT-FG	AC2,000V 1minute, Cutoff current = 10mA, DC500V 50MΩ min (20±15°C)						
	OUTPUT-FG	AC500V 1minute, Cutoff current = 100mA, DC500V 50MΩ min (20±15°C)						
ENVIRONMENT	OPERATING TEMP., HUMID. AND ALTITUDE	-40 to +100°C (On aluminum base plate), 20 - 95%RH (Non condensing) (Refer to DERATING CURVE), 3,000m (10,000 feet) max						
	STORAGE TEMP., HUMID. AND ALTITUDE	-40 to +100°C, 20 - 95%RH (Non condensing), 9,000m (30,000 feet) max						
	VIBRATION	10 - 55Hz, 49.0m/s <sup>2</sup> (5G), 3minutes period, 60minutes each along X, Y and Z axis						
	IMPACT	196.1m/s <sup>2</sup> (20G), 11ms, once each along X, Y and Z axis						
SAFETY	AGENCY APPROVALS	UL60950-1, C-UL, EN60950-1						
OTHERS	CASE SIZE/WEIGHT	58.4 × 12.7 × 37.3mm [2.3 × 0.5 × 1.47 inches] (W × H × D) / 60g max						
	COOLING METHOD	Conduction cooling (e.g. heat radiation from the aluminum base plate to the attached heat sink)						

- \*1 At rated input(DC280V) and rated load.
- \*2 Ripple and ripple noise is measured by using measuring board. Refer to the manual
- \*3 Drift is the change in DC output for an eight hour period after a half-hour warm-up at 25°C, with the input voltage held constant at the rated input/output.
- \*4 Refer to the manual for input range.



External view

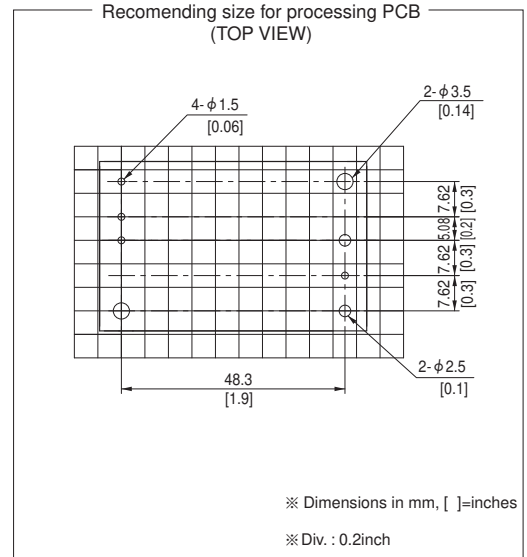
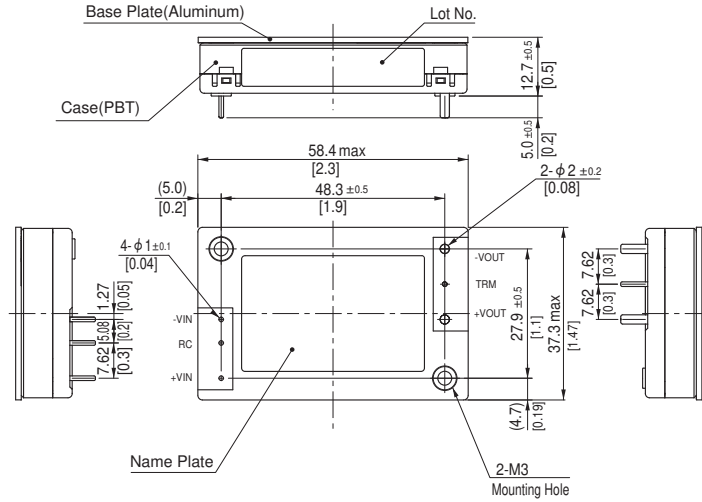

※ Dimensions in mm, [ ]=inches  
 ※ Div. : 0.2inch

- ※ Tolerance : ±0.3 [±0.012]
- ※ Weight : 60g max
- ※ Dimensions in mm, [ ]=inches
- ※ Mounting hole screwing torque : 0.49N · m (5.0kgf · cm) max

# DHS100B

DH S 100 B 05 -□

① ② ③ ④ ⑤ ⑥



RoHS



\*Providing heat sink as option

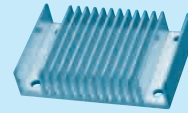

- ① Series name
- ② Single output
- ③ Output wattage
- ④ B : DC200-400V
- ⑤ Output voltage
- ⑥ Optional  
T : with Mounting hole (φ 3.4 thru)

MODEL	DHS100B03	DHS100B05	DHS100B12	DHS100B15	DHS100B24	DHS100B28
MAX OUTPUT WATTAGE[W]	66.0	100.0	100.8	100.5	100.8	100.8
DC OUTPUT	3.3V 20A	5V 20A	12V 8.4A	15V 6.7A	24V 4.2A	28V 3.6A

## SPECIFICATIONS

	MODEL	DHS100B03	DHS100B05	DHS100B12	DHS100B15	DHS100B24	DHS100B28	
INPUT	VOLTAGE[V]	DC200 - 400						
	CURRENT[A]	0.30A	0.44A	0.42A	0.42A	0.42A	0.42A	
	EFFICIENCY[%]	*1 79.0typ	82.0typ	85.0typ	86.0typ	86.0typ	86.0typ	
OUTPUT	VOLTAGE[V]	3.3	5	12	15	24	28	
	CURRENT[A]	20	20	8.4	6.7	4.2	3.6	
	LINE REGULATION[mV]	10max	10max	24max	30max	48max	56max	
	LOAD REGULATION[mV]	10max	10max	24max	30max	48max	56max	
	RIPPLE[mVp-p]	0 to +100°C *2	80max	80max	120max	120max	120max	120max
		-40 to 0°C *2	120max	120max	150max	150max	150max	150max
		0 to 15% Load *2	160max	160max	240max	240max	240max	240max
	RIPPLE NOISE[mVp-p]	0 to +100°C *2	120max	120max	150max	150max	150max	150max
		-40 to 0°C *2	200max	200max	200max	200max	250max	250max
		0 to 15% Load *2	240max	240max	300max	300max	300max	300max
	TEMPERATURE REGULATION[mV]	0 to +65°C	35max	50max	120max	150max	240max	280max
		-40 to +100°C	66max	100max	240max	300max	480max	560max
	DRIFT[mV]	*3	16max	20max	40max	60max	90max	90max
	START-UP TIME[ms]	200max (DCIN 280V, Io=100%)						
OUTPUT VOLTAGE ADJUSTMENT RANGE[V]	*4	Fixed (TRM pin open), adjustable by external VR or external voltage						
		2.97 - 3.96	4.50 - 6.00	10.80 - 13.20	13.50 - 16.50	21.60 - 26.40	25.20 - 30.80	
OUTPUT VOLTAGE SETTING[V]		3.30 - 3.40	4.97 - 5.13	11.91 - 12.29	14.76 - 15.24	23.62 - 24.38	27.56 - 28.44	
PROTECTION CIRCUIT AND OTHERS	OVERCURRENT PROTECTION	Works over 105% of rating and recovers automatically						
	OVERVOLTAGE PROTECTION[V]	4.20 - 5.70	6.30 - 7.60	13.90 - 17.55	17.25 - 21.75	27.60 - 34.80	32.20 - 40.60	
	REMOTE SENSING	None						
	REMOTE ON/OFF	Provided (Negative Logic L : ON, H :OFF)						
ISOLATION	INPUT-OUTPUT	AC3,000V 1minute, Cutoff current = 10mA, DC500V 50MΩ min (20±15°C)						
	INPUT-FG	AC2,000V 1minute, Cutoff current = 10mA, DC500V 50MΩ min (20±15°C)						
	OUTPUT-FG	AC500V 1minute, Cutoff current = 100mA, DC500V 50MΩ min (20±15°C)						
ENVIRONMENT	OPERATING TEMP., HUMID. AND ALTITUDE	-40 to +100°C (On aluminum base plate), 20 - 95%RH (Non condensing) (Refer to DERATING CURVE), 3,000m (10,000 feet) max						
	STORAGE TEMP., HUMID. AND ALTITUDE	-40 to +100°C, 20 - 95%RH (Non condensing), 9,000m (30,000 feet) max						
	VIBRATION	10 - 55Hz, 49.0m/s <sup>2</sup> (5G), 3minutes period, 60minutes each along X, Y and Z axis						
	IMPACT	196.1m/s <sup>2</sup> (20G), 11ms, once each along X, Y and Z axis						
SAFETY	AGENCY APPROVALS	UL60950-1, C-UL, EN60950-1						
OTHERS	CASE SIZE/WEIGHT	58.4 × 12.7 × 37.3mm [2.3 × 0.5 × 1.47 inches] (W × H × D) / 60g max						
	COOLING METHOD	Conduction cooling (e.g. heat radiation from the aluminum base plate to the attached heat sink)						

\*1 At rated input(DC280V) and rated load.  
 \*2 Ripple and ripple noise is measured by using measuring board. Refer to the manual.  
 \*3 Drift is the change in DC output for an eight hour period after a half-hour warm-up at 25°C, with the input voltage held constant at the rated input/output.  
 \*4 Refer to the manual for input range.

## External view

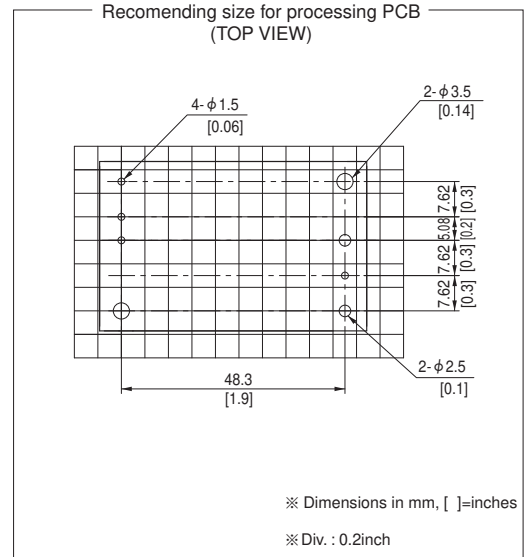
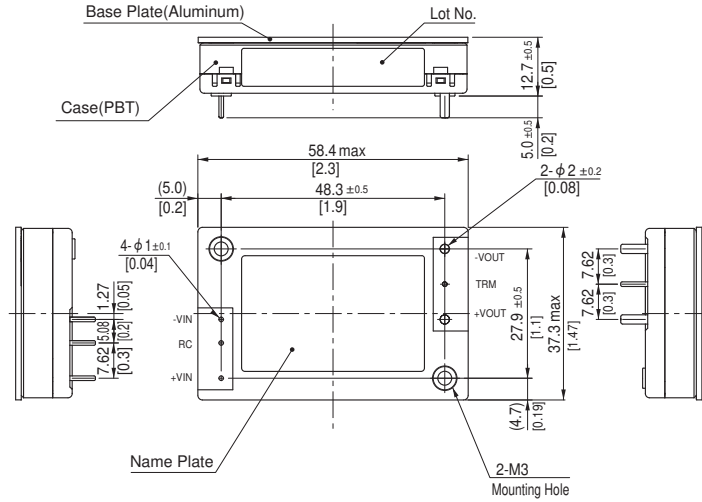

※ Dimensions in mm, [ ]=inches  
 ※ Div. : 0.2inch

- ※ Tolerance :  $\pm 0.3$  [ $\pm 0.012$ ]
- ※ Weight : 60g max
- ※ Dimensions in mm, [ ]=inches
- ※ Mounting hole screwing torque :  $0.49\text{N} \cdot \text{m}$  (5.0kgf · cm) max

# DHS250B

DH S 250 B 05 -□

① ② ③ ④ ⑤ ⑥



\*Providing heat sink as option

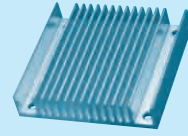

- ① Series name
- ② Single output
- ③ Output wattage
- ④ B : DC200-400V
- ⑤ Output voltage
- ⑥ Optional
- T : with Mounting hole (φ 3.4 thru)

MODEL	DHS250B03	DHS250B05	DHS250B07	DHS250B12	DHS250B15	DHS250B24	DHS250B28	DHS250B48
MAX OUTPUT WATTAGE[W]	165.0	250.0	247.5	252.0	247.5	252.0	252.0	249.6
DC OUTPUT	3.3V 50A	5V 50A	7.5V 33A	12V 21A	15V 16.5A	24V 10.5A	28V 9.0A	48V 5.2A

## SPECIFICATIONS

	MODEL	DHS250B03	DHS250B05	DHS250B07	DHS250B12	DHS250B15	DHS250B24	DHS250B28	DHS250B48	
INPUT	VOLTAGE[V]	DC200 - 400								
	CURRENT[A]	0.67A	1.0A	1.0A	1.0A	1.0A	1.0A	1.0A	1.0A	
	EFFICIENCY[%]	88.0typ	90.0typ	88.0typ	88.0typ	88.0typ	88.0typ	88.0typ	89.0typ	
OUTPUT	VOLTAGE[V]	3.3	5	7.5	12	15	24	28	48	
	CURRENT[A]	50	50	33	21	16.5	10.5	9.0	5.2	
	LINE REGULATION[mV]	10max	10max	20max	24max	30max	48max	56max	96max	
	LOAD REGULATION[mV]	10max	10max	20max	24max	30max	48max	56max	96max	
	RIPPLE[mVp-p]	0 to +100°C *2	80max	80max	100max	120max	120max	120max	120max	200max
		-40 to 0°C *2	120max	120max	130max	150max	150max	150max	150max	250max
		0 to 15% Load *2	160max	160max	200max	240max	240max	240max	240max	400max
	RIPPLE NOISE[mVp-p]	0 to +100°C *2	120max	120max	130max	150max	150max	150max	150max	250max
		-40 to 0°C *2	200max	200max	200max	200max	200max	250max	250max	400max
		0 to 15% Load *2	240max	240max	260max	300max	300max	300max	300max	500max
	TEMPERATURE REGULATION[mV]	0 to +65°C	35max	50max	70max	120max	150max	240max	280max	480max
		-40 to +100°C	66max	100max	140max	240max	300max	480max	560max	960max
	DRIFT[mV]	16max	20max	30max	40max	60max	90max	90max	180max	
	START-UP TIME[ms]	200max (DCIN 280V, Io=100%)								
OUTPUT VOLTAGE ADJUSTMENT RANGE[V]	Fixed (TRM pin open), adjustable by external VR or external voltage									
	1.98 - 3.96	3.00 - 6.00	4.50 - 8.25	7.20 - 13.20	9.00 - 16.50	14.40 - 26.40	16.80 - 30.80	28.80 - 52.80		
OUTPUT VOLTAGE SETTING[V]	3.30 - 3.40	4.97 - 5.13	7.43 - 7.67	11.91 - 12.29	14.76 - 15.24	23.62 - 24.38	27.56 - 28.44	47.24 - 48.76		
PROTECTION CIRCUIT AND OTHERS	OVERCURRENT PROTECTION	Works over 105% of rating and recovers automatically								
	OVERVOLTAGE PROTECTION[V]	4.20 - 4.85	6.30 - 7.30	8.70 - 10.20	13.90 - 16.35	17.25 - 20.25	27.60 - 32.40	32.20 - 37.80	55.20 - 64.80	
	REMOTE SENSING	Provided								
	REMOTE ON/OFF	Provided (Neqative Logic L : ON, H :OFF)								
ISOLATION	INPUT-OUTPUT	AC3,000V 1minute, Cutoff current = 10mA, DC500V 50MΩ min (20±15°C)								
	INPUT-FG	AC2,000V 1minute, Cutoff current = 10mA, DC500V 50MΩ min (20±15°C)								
	OUTPUT-FG	AC500V 1minute, Cutoff current = 100mA, DC500V 50MΩ min (20±15°C)								
ENVIRONMENT	OPERATING TEMP.,HUMID.AND ALTIUDE	-40 to +100°C (On aluminum base plate), 20 - 95%RH (Non condensing) (Refer to DERATING CURVE), 3,000m (10,000 feet) max								
	STORAGE TEMP.,HUMID.AND ALTIUDE	-40 to +100°C, 20 - 95%RH (Non condensing), 9,000m (30,000 feet) max								
	VIBRATION	10 - 55Hz, 49.0m/s <sup>2</sup> (5G), 3minutes period, 60minutes each along X, Y and Z axis								
	IMPACT	196.1m/s <sup>2</sup> (20G), 11ms, once each along X, Y and Z axis								
SAFETY	AGENCY APPROVALS	UL60950-1, C-UL, EN60950-1								
OTHERS	CASE SIZE/WEIGHT	58.4 × 12.7 × 61mm [2.3 × 0.5 × 2.4 inches](W × H × D) / 100g max								
	COOLING METHOD	Conduction cooling (e.g. heat radiation from the aluminum base plate to the attached heat sink)								

\*1 At rated input(DC280V) and rated load.  
 \*2 Ripple and ripple noise is measured by using measuring board. Refer to the manual.  
 \*3 Drift is the change in DC output for an eight hour period after a half-hour warm-up at 25°C, with the input voltage held constant at the rated input/output.  
 \*4 Refer to the manual for input range.

External view

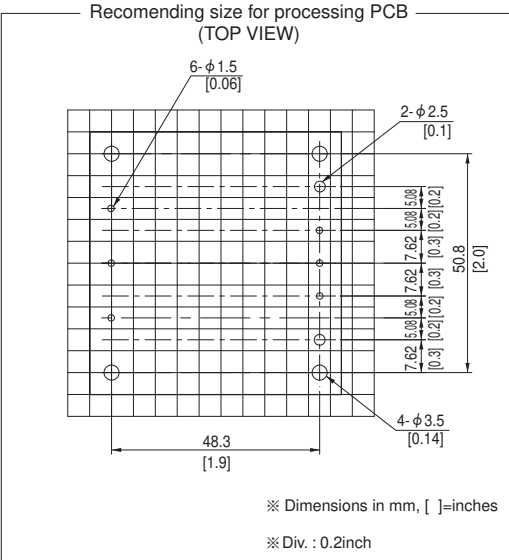
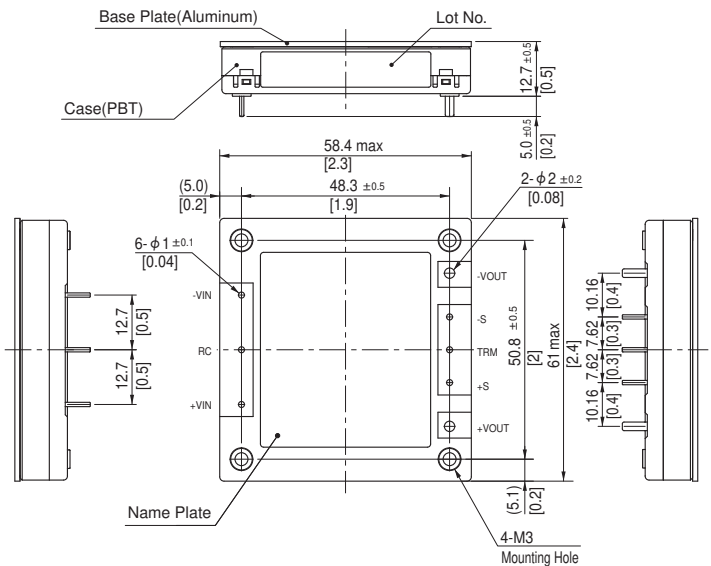

- ※ Dimensions in mm, [ ]=inches
- ※ Div. : 0.2inch
- ※ Tolerance : ±0.3 [±0.012]
- ※ Weight : 100g max
- ※ Dimensions in mm, [ ]=inches
- ※ Mounting hole screwing torque : 0.49N · m (5.0kgf · cm) max