



Chipsmall Limited consists of a professional team with an average of over 10 year of expertise in the distribution of electronic components. Based in Hongkong, we have already established firm and mutual-benefit business relationships with customers from,Europe,America and south Asia,supplying obsolete and hard-to-find components to meet their specific needs.

With the principle of "Quality Parts,Customers Priority,Honest Operation,and Considerate Service",our business mainly focus on the distribution of electronic components. Line cards we deal with include Microchip,ALPS,ROHM,Xilinx,Pulse,ON,Everlight and Freescale. Main products comprise IC,Modules,Potentiometer,IC Socket,Relay,Connector.Our parts cover such applications as commercial,industrial, and automotives areas.

We are looking forward to setting up business relationship with you and hope to provide you with the best service and solution. Let us make a better world for our industry!



Contact us

Tel: +86-755-8981 8866 Fax: +86-755-8427 6832

Email & Skype: info@chipsmall.com Web: www.chipsmall.com

Address: A1208, Overseas Decoration Building, #122 Zhenhua RD., Futian, Shenzhen, China





Cyclone III FPGA Starter Board

Reference Manual



101 Innovation Drive
San Jose, CA 95134
www.altera.com

Document Version: 1.4
Document Date: April 2012

© 2012 Altera Corporation. All rights reserved. ALTERA, ARRIA, CYCLONE, HARDCOPY, MAX, MEGACORE, NIOS, QUARTUS and STRATIX are Reg. U.S. Pat. & Tm. Off. and/or trademarks of Altera Corporation in the U.S. and other countries. All other trademarks and service marks are the property of their respective holders as described at www.altera.com/common/legal.html. Altera warrants performance of its semiconductor products to current specifications in accordance with Altera's standard warranty, but reserves the right to make changes to any products and services at any time without notice. Altera assumes no responsibility or liability arising out of the application or use of any information, product, or service described herein except as expressly agreed to in writing by Altera. Altera customers are advised to obtain the latest version of device specifications before relying on any published information and before placing orders for products or services.



Part Number MNL-01016-1.4

Chapter 1. Introduction

General Description	1-1
Board Component Blocks	1-2
Block Diagram	1-3
Handling the Board	1-3

Chapter 2. Board Components and Interfaces

Board Overview	2-1
Featured Device	2-5
Clocking Circuitry	2-6
Jumpers	2-7
Interfaces	2-8
USB Interface	2-8
HSMC Expansion Connector	2-9
General User Interfaces	2-10
Push-Buttons	2-11
LEDs	2-12
Memory	2-13
Parallel Flash	2-13
DDR SDRAM	2-15
SSRAM	2-17
Power Supply	2-19
Statement of China-RoHS Compliance	2-20

Additional Information

Revision History	Info-i
How to Contact Altera	Info-i
Typographic Conventions	Info-ii

General Description

The Cyclone® III starter board provides a hardware platform that offers a unique opportunity to customize your development environment via expansion connectors and daughtercards, as well as evaluate the feature-rich, low-power Altera® Cyclone III device.

For more functionality, you can expand the starter board through daughtercards connected to the Altera® High Speed Mezzanine Card (HSMC) connector.



For the latest information about available HSMC daughtercards, go to www.altera.com/products/devkits/kit-index.html.

The main features of the Cyclone III starter board are:

- Low-power consumption Altera Cyclone III EP3C25 chip in a 324-pin FineLine BGA (FBGA) package
- Expandable through HSMC connector
- 32-megabyte (MB) DDR SDRAM
- 16-MB parallel flash device for configuration and storage
- 1-MB high-speed SSRAM memory
- Four user push-button switches
- Four user LEDs

The main advantages of the Cyclone III starter board are:

- Facilitates a fast and successful FPGA design experience with example designs and demonstrations.
- Directly configure and communicate with the Cyclone III device via the on-board USB-Blaster™ circuitry and JTAG header
- Active parallel flash configuration
- Low power consumption
- Cost-effective modular design

Board Component Blocks

- Altera Cyclone III EP3C25F324 FPGA
 - 25K logic elements (LEs)
 - 66 M9K memory blocks (0.6 Mb)
 - 16 18x18 multiplier blocks
 - Four PLLs
 - 214 I/Os
- Clock management system
 - One 50-MHz clock oscillator to support a variety of protocols
 - The Cyclone III device distributes the following clocks from its on-board PLLs:
 - DDR clock
 - SSRAM clock
 - Flash clock
- HSMC connector
 - Provides 12 V and 3.3 V interface for installed daughtercards
 - Provides up to 84 I/O pins for communicating with HSMC daughtercards
- General user-interface
 - Four user LEDs
 - Two board-specific LEDs
 - Push-buttons:
 - System reset
 - User reset
 - Four general user push-buttons
- Memory subsystem
 - Synchronous SRAM device
 - 1-MB standard synchronous SRAM
 - 167-MHz
 - Shares bus with parallel flash device
 - Parallel flash device
 - 16-MB device for active parallel configuration and storage
 - Shares bus with SRAM device
 - DDR SDRAM device
 - 56-pin, 32-MB DDR SDRAM
 - 167-MHz
 - Connected to FPGA via dedicated 16-bit bus
- Built-in USB-Blaster interface
 - With the Altera EPM3128A CPLD
 - For external configuration of Cyclone III device
 - For system debugging with the SignalTap[®] and Nios[®] debugging console
 - Communications port for Board Diagnostic graphical user interface (GUI)

Block Diagram

Figure 1–1 shows a functional block diagram of the Cyclone III FPGA starter board.

Figure 1–1. Cyclone III FPGA Starter Board

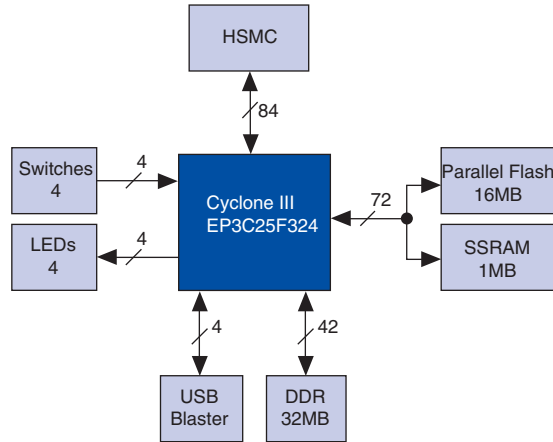

Handling the Board

When handling the board, it is important to observe the following precaution:



Static Discharge Precaution—Without proper anti-static handling, the board can be damaged. Therefore, use anti-static handling precautions when touching the board.

Board Overview

This chapter provides operational and connectivity detail for the board's major components and interfaces and is divided into the following major blocks:

- Featured device
- Clocking circuitry
- Jumpers
- Interfaces
 - USB interface
 - Altera® HSMC expansion connector
 - General user interfaces
- Memory
- Power supply
- Statement of China-RoHS compliance



The board schematics, physical layout database, and manufacturing files for the Cyclone® III FPGA starter board are included in the Cyclone III FPGA Starter Kit in the following directory:

```
<install path>\cycloneIII_3c25_start\board_design_files
```



For information on powering-up the Cyclone III FPGA starter board and installing the demonstration software, refer to the *Cyclone III FPGA Starter Kit User Guide*.

Figure 2-1 shows the top view of the Cyclone III FPGA starter board.

Figure 2-1. Top View of the Cyclone III FPGA Starter Board

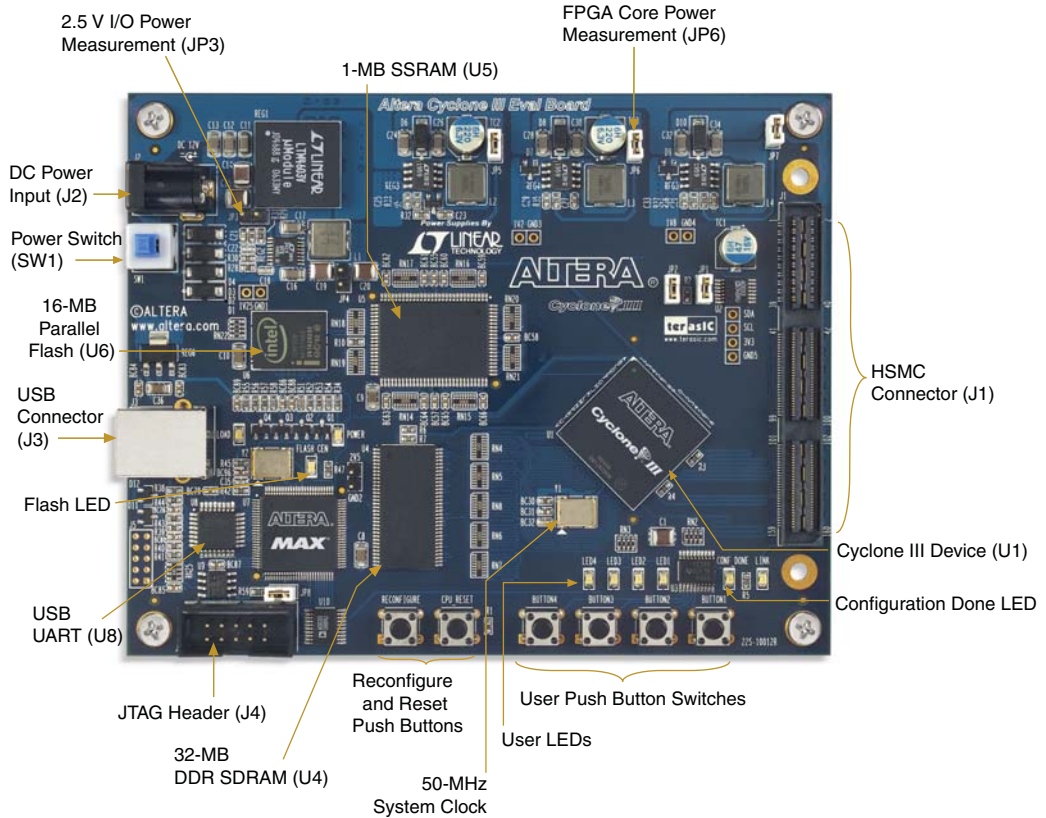

Figure 2–2 shows the diagonal view of the Cyclone III FPGA starter board.

Figure 2–2. Diagonal View of the Cyclone III FPGA Starter Board



Table 2–1 describes the components and lists their corresponding board references.

Table 2–1. Cyclone III FPGA Starter Board (Part 1 of 2)				
Type	Component/Interface	Board Reference	Description	Page
Featured Device				
FPGA	Cyclone III device	U1	EP3C25F324-C8, 324-pin FBGA package	2–5
User Interfaces				
I/O	Push-button switches	Button1–Button4, CPU Reset, Reconfigure	Four push-button switches for user-defined, logic inputs.	2–11
I/O	LEDs	LED1–LED4, Conf_Done, Link, Power, Flash_CEN, Load	Four user-defined LEDs	2–12
Connections & Interfaces				
I/O	USB UART	U8	USB interface to the Cyclone III device for external FPGA configuration and communication with applications running on the FPGA.	2–8
Input	HSMC Connector	J1	Header for connecting the HSMC interface.	2–9
Configuration & Reset				
Input	JTAG header	J4	Jumper header to select which JTAG source the board uses, for example, the JTAG header configuration or the USB JTAG configuration.	2–8
Input	USB connector	J3	Type B USB Connector that allows for connecting a Type A-B USB cable between a PC and the board.	2–8
Display	Configuration done LED	Conf_Done	LED that illuminates when FPGA is successfully configured.	2–12
Memory				
Flash	16-MB parallel flash memory	U6	16 MB of non-volatile memory.	2–13
Display	Flash LED		LED that illuminates when the flash is being accessed.	N/A
SSRAM	1-MB high-speed SSRAM	U5	256K x 32 synchronous SRAM	2–17
DDR SDRAM	32-MB DDR SDRAM	U4	4M x16 x 4 DDR SDRAM	2–15

Table 2–1. Cyclone III FPGA Starter Board (Part 2 of 2)

Type	Component/ Interface	Board Reference	Description	Page
Clock Circuitry				
Oscillator	Clock	Y1	50-MHz clock oscillator used for the system clock.	2–6
Power Supply				
Input	DC power jack	J2	12-V DC unregulated power source.	2–19
Input	Power switch	SW1	Switches the board's power on and off.	2–19
Probe point	Current sense resistor	JP6	Measure FPGA core power with current sense resistor.	N/A
Probe point	Current sense resistor	JP3	Measure 2.5-V I/O power (shared between devices) with current sense resistor.	N/A

Featured Device

The Cyclone III FPGA Starter Kit features the EP3C25F324 device (U1) in a 324-pin FineLine BGA (FBGA) package. [Table 2–2](#) lists Cyclone III device features.

Table 2–2. Cyclone III Device Features

Architectural Feature	Results
Altera's third-generation of low-cost FPGAs	<ul style="list-style-type: none"> • Lowest overall FPGA system cost available • Staggered I/O ring to decrease die area • Wide range of low-cost packages • Support for low-cost serial and parallel flash for configuration options
Lowest power consumption FPGA available	<ul style="list-style-type: none"> • Based on the TSMC's low-power 65nm process • Supports hot-socketing • Unused I/O banks can be powered down • Extends battery life for portable or hand-held applications • Eliminates or reduces cooling system costs
Increased system integration	<ul style="list-style-type: none"> • Densities up to 119,088 logic elements • High memory-to-logic ratio • Highest multiplier-to-logic ratio in the industry • Up to four dynamically reconfigurable, cascadable phase-locked-loops (PLLs), each with up to five outputs • Multi-value on-chip termination (OCT) support with calibration feature.

Table 2–3 lists the Cyclone III EP3C25F324 device pin count.

Table 2–3. Cyclone III Device Pin Count	
Board Component	Pins
SRAM/flash (shared bus)	72
SDRAM (DDR)	42 (1) (2)
Push-buttons	4
LEDs	4 (1)
USB-Blaster/configuration	4
HSMC	84 (1)
Total Pins Used	210
Total EP3C25F324 pins	214
Unused pins	4

Notes to Table 2–3:

- (1) The Cyclone III EP3C25F324 only supports one I/O standard in an I/O bank. I/O banks 3 and 4 are shared among the DDR, HSMC and LEDs.
- (2) In several DDR designs, some of the I/O pins that share the same banks with the DDR are unavailable for use due to different I/O standards. Therefore, if you have added DDR to your system, I/O banks 3 and 4 is to be configured as SSTL-2 only while the HSMC and LEDs pins which are not using SSTL-2, should be removed.

You can configure the Cyclone III device via the on-board USB-Blaster™ or through the JTAG interface using an external programming cable (sold separately).



For additional information about Altera devices, go to www.altera.com/products/devices.

Clocking Circuitry

The Cyclone III FPGA starter board’s clocking circuitry is designed to be simple and easy to use. A single 50-MHz clock input is used and all other clocks are generated using the Cyclone III device’s phase-locked loops (PLLs). The dedicated PLLs are used to distribute the flash, SSRAM, and HSMC clocks.

Table 2–4 shows the clock pinout.

Table 2–4. Clock Pinout			
Signal Name	FPGA Pin	Direction	Type
50 MHz	B9, V9	Input	2.5 V

Figure 2–3 shows the simplest clocking scheme with a single clock input; however, much more complex clocking schemes can be implemented with Cyclone III FPGAs.

Figure 2–3. Cyclone III FPGA Starter Board's Clocking Scheme

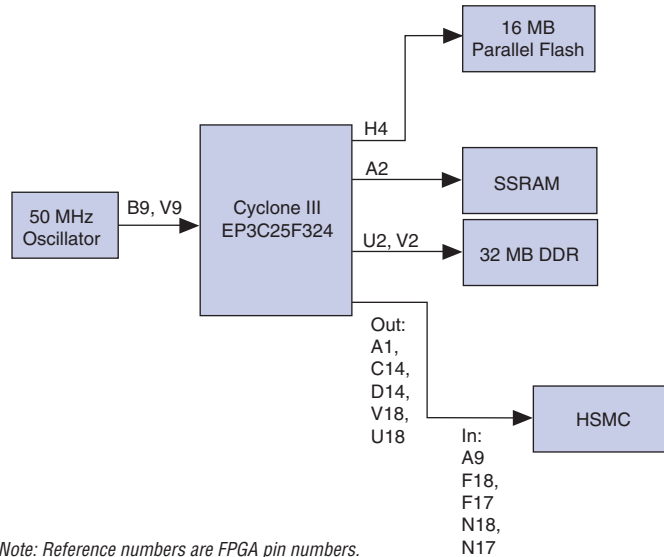

Jumpers

Table 2–5 lists board jumpers and jumper operational descriptions.

Table 2–5. Board Jumpers (Part 1 of 2)	
Jumper Board Reference	Jumper Operational Descriptions
JP1 and JP2	Removing both shunts adds the HSMC connector to the JTAG chain. If the shunts are in place on both jumpers, then the HSMC connector is removed from the JTAG chain.
JP3	Sense resistor for measuring the power consumed by the 2.5 V supply to V_{CCIO} , the DDR, the flash I/O, and the SSRAM.
JP4	1.25 V termination supply for DDR2. To supply an external voltage, remove the jumper and connect the external supply to pin 2. (Pin 2 has a rounded shape on the bottom of the board.)

Table 2–5. Board Jumpers (Part 2 of 2)

Jumper Board Reference	Jumper Operational Descriptions
JP5	3.3 V supply for the MAX device and HSMC. To supply an external voltage, remove the jumper and connect the external supply to pin 2. (Pin 2 has a rounded shape on the bottom of the board.)
JP6	Sense resistor for measuring the power consumed by the 1.2 V V_{CCINT} supply to the Cyclone III device.
JP7	1.8 V power supply to flash device. To supply an external voltage, remove the jumper and connect the external supply to pin 2. (Pin 2 has a rounded shape on the bottom of the board.)
JP8	Removing the shunt enables the embedded USB-Blaster circuitry. When the shunt is in place, use any external cable such as the ByteBlaster II, EthernetBlaster, or USB-Blaster cable to configure the Cyclone III device. (The board ships without the JTAG header populated.)

Interfaces

This section describes the following Cyclone III FPGA starter board’s interface blocks:

- USB interface
- HSMC expansion connector
- General user interfaces

USB Interface

The USB-Blaster circuitry is built onto the board. Plug the USB cable (provided with the kit) into USB connector J3 on the board and the other end to a USB port on your computer to program and communicate with the Cyclone III device via the JTAG port.

A USB physical connection is used to enable computers to communicate with the starter board. To simplify the USB interface, the board contains a FTDI FT245 FIFO circuit. The data from the FTDI chip is translated into a JTAG stream using the Altera EMP3128A CPLD connected to the Cyclone III device’s dedicated JTAG port.

The 5 V supply for the FTDI device is drawn from the USB connection. The rest of the circuit operates on 3.3 V supply with a maximum of 100 mA and 1.8 V supply with a maximum of 900 mA voltage.

HSMC Expansion Connector

The board provides one HSMC connector. The HSMC connector is a modified version of standard high-speed Samtec connectors. To provide better signal integrity between the host boards and daughtercards when using high-speed transceivers, the standard high-speed Samtec connector is modified by removing every third pin in bank -1.



CMOS utilization of the HSMC pins is assumed and no options for supporting other differential signaling is provided with the board. The eight clock-data-recovery high-speed transceiver channels are not connected.

Table 2-6 lists the ordering codes and shows the relationship between the standard Samtec Q-series connectors and the modified parts' ordering codes.

<i>Table 2-6. Altera-Specific & Standard Samtec Part Numbers</i>		
	Altera-Specific Samtec Part Number	Standard Samtec Part Number
Daughtercards	ASP-122952-01	QTH-090-01-L-D-A
Host boards	ASP-122953-01	QTH-090-01-L-D-A

The board provides both 12 V unregulated and 3.3 V regulated power supply to the HSMC connector for any installed daughtercards.



For more information about the HSMC, refer to the *High Speed Mezzanine Card (HSMC) Specification*.

Table 2-7 lists the guaranteed minimum on-board power supply levels. Designated pins on the HSMC connector deliver the power rails.

<i>Table 2-7. HSMC Power Requirements</i>		
Voltage	Current Rating	Maximum Power
12 V	1.0 A	12.0 W
3.3 V	2.0 A	6.6 W

Table 2-8 lists the HSMC A connector board reference and manufacturing information.

Board Reference	Description	Manufacturer	Manufacturer Part Number
J1	High speed Mezzanine card connector	Samtec	ASP-12953-01

The HSMC uses the Samtec connector’s header provided on the board. Figure 2-4 shows the outline of the Samtec header.

Figure 2-4. Samtec Connector’s Header

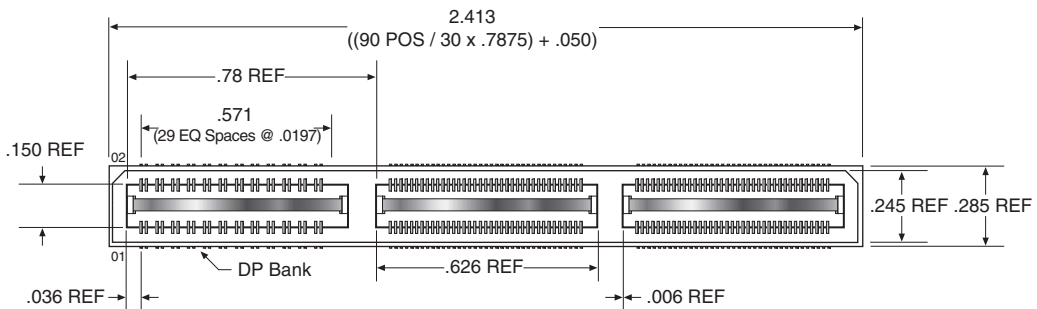

General User Interfaces

To allow you to fully use the I/O capabilities of the Cyclone III device, the following user interfaces are available on the board (remaining I/Os are connected to additional board resources):

- Push-buttons: System and user reset, and user-defined push-buttons
- LEDs: Board-specific and user-defined LEDs

Some of the board’s buttons and LEDs have a specific board function while others are user-defined and are provided to control FPGA designs.

Push-Buttons

The board has system reset, user reset, and user push-buttons. Table 2-9 lists the pinout for all push-buttons. The push-buttons are in logic “1” until depressed.

Signal Name	FPGA Pin	Direction	Type
KEY0	F1	Input	2.5 V
KEY1	F2	Input	2.5 V
KEY2	A10	Input	2.5 V
KEY3	B10	Input	2.5 V
CPU_RESET_N	N2	Input	2.5 V
RECONFIGURE	H5 (nConfig)	Input	2.5 V

Figure 2-5 shows the push-buttons.

Figure 2-5. Push-Buttons



System Reset Push-Buttons

The system reset push-button starts a reconfiguration of the FPGA from flash memory.

User Reset Push-Buttons

The user reset push-button is an input to the Cyclone III device. This push-button is intended to be the master reset signal for the FPGA designs loaded into the Cyclone III device. The user reset push-button is connected to the DEV_CLRn pin on the FPGA. The DEV_CLRn setting is a pin option in the Quartus II software that you must enable to function as DEV_CLRn instead of a standard I/O.

User Push-Buttons

The four user push-buttons are intended for use in controlling FPGA designs loaded into the Cyclone III device. There is no board-specific function for these four push-buttons.

LEDs

The board has user LEDs and board-specific LEDs. Table 2–10 lists both user and board-specific LED pinout. A logic “0” illuminate the LEDs.

<i>Table 2–10. Board LED Pinout</i>			
Signal Name	FPGA Pin Name	Direction	Type
LED0	P13	Output	2.5 V
LED1	P12	Output	2.5 V
LED2	N12	Output	2.5 V
LED3	N9	Output	2.5 V
Power LED	—	—	—
MAX Load LED	—	—	—
conf done LED	—	—	—
Flash LED	—	—	—
HSMC Present LED	—	—	—

Figure 2–6 shows the LEDs.

Figure 2–6. LEDs



User LEDs

Status and debugging signals are driven to the user LEDs from FPGA designs loaded into the Cyclone III device. There is no board-specific function for the user LEDs.

Board Specific LEDs

The power LED illuminates when the board's power is on and working. The configuration done LED illuminates when the FPGA is configured.



Because of the Quartus II software pin placement rules in various memory banks, you may only be able to use one or two of the LEDs with DDR designs.

- Configuration done LED: The `Conf_Done` LED illuminates when the FPGA is configured with any design.
- Flash signal LED: The `flash_CE_n` LED illuminates when the `CE_n` signal to the flash is asserted indicating the flash is being accessed.
- Power LED: The power LED illuminates when power is applied to the board.

Memory

The Cyclone III FPGA starter board includes the following memories:

- Parallel flash
- DDR SDRAM
- SSRAM

Parallel Flash

The Cyclone III starter board has a 8M x 16 low voltage parallel flash. [Table 2–11](#) lists the parallel flash board reference and manufacturing information.

Table 2–11. Parallel Flash Manufacturing Information

Board Reference	Description	Manufacturer	Manufacturer Part Number
U6	8M x16 low voltage parallel flash	Intel	PC28F128P30BF65

[Table 2–12](#) shows the parallel flash signal name, corresponding FPGA pin, signal direction, type, and board reference U6 flash pin.

Table 2–12. Parallel Flash Memory Pinout (Part 1 of 3)

Signal Name	FPGA Pin	Direction	Type	U6 (Flash) Pin
<code>flash_sram_a1</code>	E12	Output	2.5 V	A1
<code>flash_sram_a2</code>	A16	Output	2.5 V	B1
<code>flash_sram_a3</code>	B16	Output	2.5 V	C1
<code>flash_sram_a4</code>	A15	Output	2.5 V	D1

Table 2–12. Parallel Flash Memory Pinout (Part 2 of 3)

Signal Name	FPGA Pin	Direction	Type	U6 (Flash) Pin
flash_sram_a5	B15	Output	2.5 V	D2
flash_sram_a6	A14	Output	2.5 V	A2
flash_sram_a7	B14	Output	2.5 V	C2
flash_sram_a8	A13	Output	2.5 V	A3
flash_sram_a9	B13	Output	2.5 V	B3
flash_sram_a10	A12	Output	2.5 V	C3
flash_sram_a11	B12	Output	2.5 V	D3
flash_sram_a12	A11	Output	2.5 V	C4
flash_sram_a13	B11	Output	2.5 V	A5
flash_sram_a14	C10	Output	2.5 V	B5
flash_sram_a15	D10	Output	2.5 V	C5
flash_sram_a16	E10	Output	2.5 V	D7
flash_sram_a17	C9	Output	2.5 V	D8
flash_sram_a18	D9	Output	2.5 V	A7
flash_sram_a19	A7	Output	2.5 V	B7
flash_sram_a20	A6	Output	2.5 V	C7
flash_sram_a21	B18	Output	2.5 V	C8
flash_sram_a22	C17	Output	2.5 V	A8
flash_sram_a23	C18	Output	2.5 V	G1
flash_sram_a24	G14	Output	2.5 V	H8
flash_sram_a25	B17	Output	2.5 V	B6
flash_sram_dq0	H3	Bidirectional	2.5 V	F2
flash_sram_dq1	D1	Bidirectional	2.5 V	E2
flash_sram_dq2	A8	Bidirectional	2.5 V	G3
flash_sram_dq3	B8	Bidirectional	2.5 V	E4
flash_sram_dq4	B7	Bidirectional	2.5 V	E5
flash_sram_dq5	C5	Bidirectional	2.5 V	G5
flash_sram_dq6	E8	Bidirectional	2.5 V	G6
flash_sram_dq7	A4	Bidirectional	2.5 V	H7
flash_sram_dq8	B4	Bidirectional	2.5 V	E1
flash_sram_dq9	E7	Bidirectional	2.5 V	E3
flash_sram_dq10	A3	Bidirectional	2.5 V	F3
flash_sram_dq11	B3	Bidirectional	2.5 V	F4
flash_sram_dq12	D5	Bidirectional	2.5 V	F5

Table 2–12. Parallel Flash Memory Pinout (Part 3 of 3)

Signal Name	FPGA Pin	Direction	Type	U6 (Flash) Pin
flash_sram_dq13	B5	Bidirectional	2.5 V	H5
flash_sram_dq14	A5	Bidirectional	2.5 V	G7
flash_sram_dq15	B6	Bidirectional	2.5 V	E7
flash_we_n	D18	Output	2.5 V	G8
flash_ce_n	E2	Output	2.5 V	B4
flash_oe_n	D17	Output	2.5 V	F8
flash_reset_n	C3	Output	2.5 V	D4
flash_adv_n	H14	Output	2.5 V	F6
flash_clk (dclk)	H4	Output	2.5 V	E6
flash_wait	H13	Output	2.5 V	F7

DDR SDRAM

The Cyclone III FPGA starter board has a 4M x 16 x 4 DDR SDRAM. [Table 2–13](#) lists DDR SDRAM board reference and manufacturing information.

Table 2–13. DDR SDRAM Manufacturing Information

Board Reference	Description	Manufacturer	Manufacturer Part Number
U4	4M x16 x 4 DDR SDRAM	PowerChip Semiconductor	A2S56D40CTP-G5PP

[Table 2–14](#) shows the DDR SDRAM signal name, corresponding FPGA pin, signal direction, type, and board reference U4 DDR pin.

Table 2–14. DDR SDRAM Pinout (Part 1 of 3) Note (1)

Signal Name	FPGA Pin	Direction	Type	U4 (DDR) Pin
ddr_dqs0	U3	Bidirectional	SSTL-2	16
ddr_dqs1	T8	Bidirectional	SSTL-2	51
ddr_dm0	V3	Output	SSTL-2	47
ddr_dm1	V8	Output	SSTL-2	20
ddr_ba0	V11	Output	SSTL-2	26
ddr_ba1	V12	Output	SSTL-2	27
ddr_cas_n	T4	Output	SSTL-2	22

Table 2–14. DDR SDRAM Pinout (Part 2 of 3) Note (1)

Signal Name	FPGA Pin	Direction	Type	U4 (DDR) Pin
ddr_cke	R13	Output	SSTL-2	44
ddr_cs_n	V1	Output	SSTL-2	24
ddr_ras_n	V16	Output	SSTL-2	23
ddr_we_n	U15	Output	SSTL-2	21
ddr_clk	U2	Bidirectional	SSTL-2	45
ddr_clk_n	V2	Bidirectional	SSTL-2	46
ddr_a0	U1	Output	SSTL-2	29
ddr_a1	U5	Output	SSTL-2	30
ddr_a2	U7	Output	SSTL-2	31
ddr_a3	U8	Output	SSTL-2	32
ddr_a4	P8	Output	SSTL-2	35
ddr_a5	P7	Output	SSTL-2	36
ddr_a6	P6	Output	SSTL-2	37
ddr_a7	T14	Output	SSTL-2	38
ddr_a8	T13	Output	SSTL-2	39
ddr_a9	V13	Output	SSTL-2	40
ddr_a10	U17	Output	SSTL-2	28
ddr_a11	V17	Output	SSTL-2	41
ddr_a12	U16	Output	SSTL-2	42
ddr_dq0	U4	Bidirectional	SSTL-2	2
ddr_dq1	V4	Bidirectional	SSTL-2	4
ddr_dq2	R8	Bidirectional	SSTL-2	5
ddr_dq3	V5	Bidirectional	SSTL-2	7
ddr_dq4	P9	Bidirectional	SSTL-2	8
ddr_dq5	U6	Bidirectional	SSTL-2	10
ddr_dq6	V6	Bidirectional	SSTL-2	11
ddr_dq7	V7	Bidirectional	SSTL-2	13
ddr_dq8	U13	Bidirectional	SSTL-2	54
ddr_dq9	U12	Bidirectional	SSTL-2	56
ddr_dq10	U11	Bidirectional	SSTL-2	57
ddr_dq11	V15	Bidirectional	SSTL-2	59
ddr_dq12	U14	Bidirectional	SSTL-2	60
ddr_dq13	R11	Bidirectional	SSTL-2	62
ddr_dq14	P10	Bidirectional	SSTL-2	63

Table 2–14. DDR SDRAM Pinout (Part 3 of 3) Note (1)

Signal Name	FPGA Pin	Direction	Type	U4 (DDR) Pin
ddr_dq15	V14	Bidirectional	SSTL-2	65

Note to **Table 2–14**:

- (1) The Cyclone III EP3C25F324 only supports one I/O standard in an I/O bank. I/O banks 3 and 4 are shared among the DDR, HSMC and LEDs. In several DDR designs, some of the I/O pins that share the same banks with the DDR are unavailable for use due to different I/O standards. Therefore, if you have added DDR to your system, I/O banks 3 and 4 is to be configured as SSTL-2 only while the HSMC and LEDs pins which are not using SSTL-2, should be removed.

SSRAM

The Cyclone III FPGA starter board has a 256K x 32 synchronous SRAM. **Table 2–15** lists SSRAM board reference and manufacturing information.

Table 2–15. SSRAM Manufacturing Information

Board Reference	Description	Manufacturer	Manufacturer Part Number
U5	256K x 32 synchronous SRAM	Integrated Silicon Solutions, Inc.	IS61LPS25636A-200TQL1

Table 2–16 shows the SSRAM signal name, corresponding FPGA pin, signal direction, type, and board reference U5 SSRAM pin.

Table 2–16. SSRAM Pinout (Part 1 of 3)

Signal Name	FPGA Pin	Direction	Type	U5 (SSRAM) Pin
flash_sram_a2	A16	Output	2.5 V	37
flash_sram_a3	B16	Output	2.5 V	36
flash_sram_a4	A15	Output	2.5 V	35
flash_sram_a5	B15	Output	2.5 V	34
flash_sram_a6	A14	Output	2.5 V	33
flash_sram_a7	B14	Output	2.5 V	32
flash_sram_a8	A13	Output	2.5 V	44
flash_sram_a9	B13	Output	2.5 V	45
flash_sram_a10	A12	Output	2.5 V	46
flash_sram_a11	B12	Output	2.5 V	47
flash_sram_a12	A11	Output	2.5 V	48
flash_sram_a13	B11	Output	2.5 V	49