



Chipsmall Limited consists of a professional team with an average of over 10 year of expertise in the distribution of electronic components. Based in Hongkong, we have already established firm and mutual-benefit business relationships with customers from,Europe,America and south Asia,supplying obsolete and hard-to-find components to meet their specific needs.

With the principle of "Quality Parts,Customers Priority,Honest Operation,and Considerate Service",our business mainly focus on the distribution of electronic components. Line cards we deal with include Microchip,ALPS,ROHM,Xilinx,Pulse,ON,Everlight and Freescale. Main products comprise IC,Modules,Potentiometer,IC Socket,Relay,Connector.Our parts cover such applications as commercial,industrial, and automotives areas.

We are looking forward to setting up business relationship with you and hope to provide you with the best service and solution. Let us make a better world for our industry!



Contact us

Tel: +86-755-8981 8866 Fax: +86-755-8427 6832

Email & Skype: info@chipsmall.com Web: www.chipsmall.com

Address: A1208, Overseas Decoration Building, #122 Zhenhua RD., Futian, Shenzhen, China





PIC32™ Industrial Host StackableUSB™ Microcontroller USB1032



Features

- ✓ 80MHz system clock
- ✓ 1.56 DMIPS/MHz performance
- ✓ 512KB Flash, 32KB SRAM memory
- ✓ Single-cycle multiply and high-performance divide unit
- ✓ On-board RS232 transceiver
- ✓ Easy development with Microchip's MPLAB IDE
- ✓ Small 1.85" x 1.74" board
- ✓ -40° to +85°C operation



The USB1032 is the ideal module for applications requiring more performance than typical micro-controllers have offered but not needing the full blast offered by an SBC. Well-suited for applications confined to small, tight spaces, the 125 DMIPS performance requires only 100mA power, considerably less than an SBC.

The USB1032 is powered by the PIC32 microcontroller whose USB 2.0 On-The-Go (OTG) functionality allows the microcontroller to be used as a Host. Operating as a Host device, design engineers can easily and cost-effectively stack StackableUSB client I/O devices onto the controller making a small, embedded controller ideally suited to harsh environments.

Available onboard is a host of control features including 10-bit ADC, RS232, four (4) programmable LEDs, and digital I/O. Developers will appreciate the PIC32's easy-to-use and solidly-supported software tools as they program and debug.

The 1.85" x 1.74" module is USB 2.0 compliant providing users the advantages of plug-and-play interfacing. The module stacks onto the top or bottom of any StackableUSB client single board computer or microcontroller forming a small, rugged, embeddable system, ideal for harsh environments. The USB1032 can be connected to desktop PCs and laptops via ICSP for development.

Software/Driver Support

Windows XP, Vista
MPLAB IDE
MPLAB C32 C Compiler
USB Host stack
Graphics & audio library
16- and 32-bit File System
TCP/IP Stack
Sample software

Compatible Hardware

StackableUSB Client devices
ICE
ICD3

Mounting/Packaging

1/4-Size 104™ Form Factor
Standoffs, STDOFFUSB

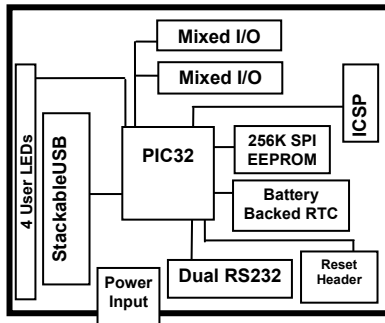

Specifications:

Mechanical:

- ❑ 1.85" x 1.74" StackableUSB
- ❑ ¼-Size 104™ Form Factor

Power Requirements:

- ❑ +5v ±5% at 100mA typical

Environmental:

- ❑ -40 to +85°C operating
- ❑ -40° to +85°C storage
- ❑ 5%-95% relative humidity, non-condensing

Processor:

- ❑ MIPS32® M4K™ 32-bit core
- ❑ 80MHz, 1.56DMIPS/MHz
- ❑ 5-stage pipeline, 32-bit ALU
- ❑ Single-cycle multiply and high-performance divide unit
- ❑ User and kernel modes to enable robust embedded system
- ❑ Prefetch cache module to speed execution from flash
- ❑ 512KB Flash, 32KB SRAM

Serial Ports:

- ❑ Two (2) RS232 available from 20-pin header

LEDs/Switches:

- ❑ Four (4) programmable user LEDs
- ❑ One (1) reset header

Peripheral Features:

- ❑ 4-channel hardware DMA controller with automatic data size detection
- ❑ USB 2.0 compliant full speed controller
- ❑ USB has a dedicated DMA channel
- ❑ Two (2) I2C modules
- ❑ Two (2) UART modules with:
 - RS232, RS485 and LIN 1.2 support
 - IrDA® with on-chip hardware encoder and decoder
- ❑ Parallel master and slave port
- ❑ Hardware real-time clock/calendar
- ❑ Five (5) 16-bit timers/counters (two 16-bit pairs combine to create two 32-bit timers)
- ❑ Five (5) capture inputs
- ❑ Five (5) compare/PWM outputs
- ❑ Five (5) external interrupt pins
- ❑ High-speed I/O pins capable of toggling at up to 80MHz
- ❑ High-current sink/source (18 mA/18 mA) on all I/O pins
- ❑ Configurable open-drain output on digital I/O pins

Analog Features:

- ❑ 16-channel 10-bit analog-to-digital converter
- ❑ 500 KSPS conversion rate
- ❑ Conversion available during sleep, idle
- ❑ Two (2) analog comparators
- ❑ 5.5V tolerant input pins (digital pins only)

Debug Features:

- 2-wire ICSP interface with unobtrusive access and real-time data exchange with application

External Connections:

- 2-pin power terminal
- StackableUSB
- 20-pin header for COM1 and COM2
- 6-pin ICSP debug port
- 2x40-pin headers for I/O and peripherals

Internal Electrical Interface:

- StackableUSB
- USB 1.1 & 2.0 compatible, full-speed

Development Kit:

- Module
- Complete cable set
- Documentation, sample software

Ordering Information:**OEM Single Board Computers:**

USB1032	PIC32 Industrial Host Microcontroller
CS1032	Complete cable set
1032OPT1	Battery Backed RTC
1032OPT2	256K SPI EEPROM

Related Products:

STDOFFUSB	StackableUSB standoff kit
BA4040	40-pin mixed I/O header breakout cable
BA2018	20-pin RS232 header to dual DB9 breakout cable
CA4142	ICSP programming/ debugging cable

Development Board Kits*

DK1032	PIC32 Industrial Host Microcontroller; Windows- ready development kit
--------	---

**See Development Kit Specifications*