



Chipsmall Limited consists of a professional team with an average of over 10 year of expertise in the distribution of electronic components. Based in Hongkong, we have already established firm and mutual-benefit business relationships with customers from,Europe,America and south Asia,supplying obsolete and hard-to-find components to meet their specific needs.

With the principle of “Quality Parts,Customers Priority,Honest Operation,and Considerate Service”,our business mainly focus on the distribution of electronic components. Line cards we deal with include Microchip,ALPS,ROHM,Xilinx,Pulse,ON,Everlight and Freescale. Main products comprise IC,Modules,Potentiometer,IC Socket,Relay,Connector.Our parts cover such applications as commercial,industrial, and automotives areas.

We are looking forward to setting up business relationship with you and hope to provide you with the best service and solution. Let us make a better world for our industry!



## Contact us

Tel: +86-755-8981 8866 Fax: +86-755-8427 6832

Email & Skype: info@chipsmall.com Web: www.chipsmall.com

Address: A1208, Overseas Decoration Building, #122 Zhenhua RD., Futian, Shenzhen, China



# TE Connectivity DEUTSCH DL Series MIL-DTL-83723 Series III Connectors



## INTERMATEABLE WITH SOURIAU CONNECTORS AND ALL MIL-DTL-83723 SERIES III

TE DEUTSCH DL series MIL-DTL-83723 series III connectors have a quick-mating, three-point bayonet coupling system. TE DEUTSCH DL series connectors are designed for the harsh environments found in communications equipment, industrial equipment, and armored tanks, and are excellent aerospace connectors. These TE DEUTSCH connectors are mil spec to MIL-83723 and have a high-quality contact retention system. The DL series is intermateable with Souriau connectors, all MIL-DTL-83723 series III connectors, and all MIL-DTL-26500 bayonet connectors. For full product details on the TE DEUTSCH DL series MIL-DTL-83723 series III connectors, please see the specifications below.

## APPLICATIONS

- High-performance military aircraft
- Commercial aircraft
- Communications equipment
- Armored personnel carriers & tanks
- High temperature industrial equipment

## FEATURES

- High-reliability
- Outstanding EMI-shielding protection
- Operates at extreme temperatures
- High-density connectors
- Broad range of military and commercial accessories
- MIL-DTL-83723 qualified

TECHNICAL  
SPECIFICATIONS**MATERIALS AND FINISHES**

Shell	Aluminium Alloy or Stainless Steel
Shell Plating	Electroless Nickel, Olive Drab Chromate over nickel, Anodized, and Passivated
Bayonet Pin	Passivated Stainless Steel
Contacts	Copper Alloy
Contact Platings	50u" Gold Plated
Insulator	Rigid Plastic dielectric
Seals	Silicone based elastomer

**ELECTRICAL DATA**

## Test Voltage

SERVICE RATING	SEA LEVEL VAC RMS	50000 FEET ALTITUDE VAC RMS	70000 FEET ALTITUDE VAC RMS	110000 FEET ALTITUDE VAC RMS
I	1500	500	375	200
II	2300	750	500	200

## Current Rating

CONTACT SIZE	DC TEST CURRENT IN AMPS	POTENTIAL DROP MILLIVOLT AT 77°F (25°C)
20	7.5	<15
16	13	<21
12	23	<22

**MECHANICAL DATA**

Wire Range Sizes	12-24AWG
Insulation Resistance	5000 Megaohms minimum at 77°F (25°C)
Mating Life	500 cycle minimum
Salt Spray	48 hours unmated; 452 hours mated
Heat	Class A,R, & G +392°F (200°C), Class W +347°F (175°C) for 1000 hours
Vibration	10 to 2000Hz (20g's) 1 microseconds maximum discontinuity.
Shock	300g's for 3 microseconds duration, 1 microsecond maximum discontinuity
Contact Type	Crimp, coax, shielded, printed circuit board, thermocouple, and fiber optic
Number of Circuits	3 to 61
Polarization	Five keyway, three point bayonet with optional keyed polarization shells or rotation of insert
Approvals/Agency Listing	MIL-DTL-83723

Contact Retention

CONTACT SIZE	RETENTION AXIAL LOAD +/-10 PERCENT		SEPARATION FORCE MINIMUM (INITIAL)	
	NEWTONS	LBS.	NEWTONS	OUNCES
20	88.9	20	0.194	0.7
16	111.2	25	0.556	2
12	133.4	30	0.834	3

Wire Sealing Range

CONTACT SIZE	WIRE SEALING RANGE MIN.		WIRE SEALING RANGE MAX.	
	IN	MM	IN	MM
20	0.040	1.02	0.083	2.11
16	0.053	1.35	0.103	2.62
12	0.097	2.46	0.158	4.01
8	0.164	4.17	0.255	6.48
4	0.288	7.32	0.370	9.40
0	0.415	10.54	0.550	13.97

HOW TO ORDER 83723/DL SERIES CONNECTORS - MILITARY



(Military part number example)

**STEP 1: SELECT SHELL STYLE, PLUG OR RECEPTACLE**

RECEPTACLES ← Mates with → PLUGS

↓	↓	↓	↓
			
<b>M83723/71</b> with Socket contacts	<b>M83723/73</b> with Socket contacts	<b>M83723/75</b> with Socket contacts	<b>M83723/77</b> with Socket contacts
<b>M83723/72</b> with Pin contacts Square Flange Receptacle	<b>M83723/74</b> with Pin contacts Jam Nut Receptacle	<b>M83723/76</b> with Pin contacts Standard Plug	<b>M83723/78</b> with Pin contacts Shielded Plug

MATING GUIDE

	/71	/72	/73	/74	/75	/76	/77	/78
/71						*		*
/72					*		*	
/73						*		*
/74					*		*	
/75		*		*				
/76	*		*					
/77		*		*				
/78	*		*					

Mating connectors will mate a plug to a receptacle, so long as the layout and keying are the same and the contact types are opposite.

**STEP 2: SELECT FINISH**



- A\*** = Aluminium Shell, black non-conductive anodized plated
- R** = Aluminium Shell, electroless nickel plated
- W** = Aluminium Shell, olive drab cadmium plated

\*not available for styles /77 and /78

**STEP 3: SELECT LAYOUT**

⇒ See page 96-97 for listing by # of contacts

LAYOUT NUMBER	SERVICE RATING	CONTACTS			
		TOTAL NUMBER	20	16	12
0803	I	3	3		
0898	I	3	3		
1002	I	2	2		
1005	I	5	5		
1006	I	6	6		
1020	I	2		2	
1203	I	3		3	
1212	I	12	12		
1404	I	4			4
1407	I	7		7	
1412	I	12	9	3	
1415	I	15	15		
1610	I	10		10	
1624	I	24	24		
1808	I	8			8
1814	I	14		14	
1831	I	31	31		
2016	I	16		16	
2025	I	25	19		6
2028	I	28	24		4
2039	I	39	37	2	
2041	I	41	41		
2212	I	12			12
2219	I	19		19	
2232	I	32	26		6
2255	I	55	55		
2419	I	19			19
2443	I	43	23	20	
2457	I	57	55		2
2461	I	61	61		

**STEP 4: SELECT POLARIZATION**

- N = Normal
- 6 = Keyed Shell
- 7 = Keyed Shell
- 8 = Keyed Shell
- 9 = Keyed Shell
- Y\*\* = Keyed Shell

- N = Normal Rotation
- 1 = Insert Rotation \*\*\*
- 2 = Insert Rotation \*\*\*
- 3 = Insert Rotation \*\*\*
- 4 = Insert Rotation \*\*\*
- 5 = Insert Rotation \*\*\*

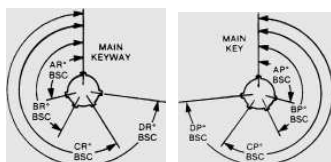

Receptacles

Plug

ALTERNATE KEYING POSITIONS OF SHELL					
SHELL SIZE	POLARIZING POSITION	KEYWAY ANGLE (DEGREES)			
		A	B	C	D
8 thru 24	N	105	140	215	265
	6	102	132	248	320
	7	80	118	230	312
8 & 10	8	35	140	205	275
	9	64	155	234	304
10 only	Y**	25	115	220	270
12 thru 28	6	18	149	192	259
	7	92	152	222	342
	8	84	152	204	334
	9	24	135	199	240
	Y**	98	152	268	338

\*\* Position Y supersedes inactive positions 10 & Z designations. Ref MIL-STD-1554

ALTERNATE ROTATIONS OF LAYOUTS ***		
SHELL SIZE	POLARIZING POSITION	INSERT ANGLE (DEGREE)
8 & 10	N	0
	1	10
	2	20
	3	30
	4	40
12 thru 28	5	50
	N	0
	1	10
	2	20
	3	30
	4	40
	5	50

\*\*\* Positions 1-5 are inactive for new designs per MIL-STD-1554.

**STEP 5: SELECT MODIFIER**

-LC = for use with standard contacts, but supplied without contacts, seal plugs or tools (PO must state Less Contacts)

**Note:** -LC is not marked on part

HOW TO ORDER 83723/DL SERIES CONNECTORS - COMMERCIAL

<b>1</b>	<b>2</b>	<b>3</b>	<b>4</b>	<b>5</b>	<b>6</b>
<b>DL66R</b>	<b>12-10</b>	<b>P</b>	<b>N</b>	<b>-6117</b>	<b>-LC</b>
<b>SHELL STYLE</b>	<b>LAYOUT</b>	<b>CONTACT</b>	<b>POLARIZATION</b>	<b>FINISH</b>	<b>MODIFIER</b>

(Commercial part number example)

**STEP 1: SELECT SHELL STYLE, PLUG OR RECEPTACLE**

**RECEPTACLES** ← Mates with → **PLUGS**



**STEP 2: SELECT LAYOUT**

⇒ See page 96-97 for listing by # of contacts

LAYOUT NUMBER	SERVICE RATING	CONTACTS			
		TOTAL NUMBER	20	16	12
8-3	I	3	3		
8-98	I	3	3		
10-2	I	2	2		
10-5	I	5	5		
10-6	I	6	6		
10-20	I	2		2	
12-3	I	3		3	
12-12	I	12	12		
14-4	I	4			4
14-7	I	7		7	
14-12	I	12	9	3	
14-15	I	15	15		
16-10	I	10		10	
16-24	I	24	24		
18-08	I	8			8
18-14	I	14		14	
18-31	I	31	31		
20-16	I	16		16	
20-25	I	25	19		6
20-28	I	28	24		4
20-39	I	39	37	2	
20-41	I	41	41		
22-12	I	12			12
22-19	I	19		19	
22-21	I	21		21	
22-32	I	32	26		6
22-55	I	55	55		
24-19	I	19			19
24-43	I	43	23	20	
24-57	I	57	55		2
24-61	I	61	61		

**STEP 3: SELECT CONTACT**

**P** = Pin      **S** = Socket

**STEP 4: SELECT POLARIZATION**

- N** = Normal
- 6** = Keyed Shell
- 7** = Keyed Shell
- 8** = Keyed Shell
- 9** = Keyed Shell
- Y\*\*** = Keyed Shell

ALTERNATE KEYING POSITIONS OF SHELL					
SHELL SIZE	POLARIZING POSITION	KEYWAY ANGLE (DEGREES)			
		A	B	C	D
8 thru 24	N	105	140	215	265
8 & 10	6	102	132	248	320
	7	80	118	230	312
	8	35	140	205	275
	9	64	155	234	304
10 only	Y**	25	115	220	270
12 thru 28	6	18	149	192	259
	7	92	152	222	342
	8	84	152	204	334
	9	24	135	199	240
	Y**	98	152	268	338

\*\* Position Y supersedes inactive positions 10 & Z designations. Ref MIL-STD-1554

**STEP 5: SELECT FINISH**

- 6116\*** = Aluminium Shell, black non-conductive anodized plated
- 6117** = Aluminium Shell, olive drab cadmium plated
- 6106** = Aluminium Shell, electroless nickel plated

\*Not available for shell type DL68G

**STEP 6: SELECT MODIFIER**

**-LC** = for use with standard contacts, but supplied without contacts, seal plugs or tools (PO must state Less Contacts)

**Note:** -LC is not marked on part



LAYOUTS BY SHELL SIZE

○=20 ●=16 ◐=12

LAYOUT	8-3	8-98	10-2	10-5	10-6
# OF CONTACTS	3-#20	3-#20	2-#20	5-#20	6-#20
SERVICE RATING	I	I	I	I	I
LAYOUT	10-20	12-3	12-12	14-4	14-7
# OF CONTACTS	2-#16	3-#16	12-#20	4-#12	7-#16
SERVICE RATING	I	I	I	I	I
LAYOUT	14-12	14-15	16-10	16-24	18-08
# OF CONTACTS	9-#20, 3-#16	15-#20	10-#16	24-#20	8-#12
SERVICE RATING	I	I	I	I	I
LAYOUT	18-14	18-31	20-16	20-25	20-28
# OF CONTACTS	14-#16	31-#20	16-#16	19-#20, 6-#12	24-#20, 4-#12
SERVICE RATING	I	I	I	I	I

# LAYOUTS BY SHELL SIZE

○=20   ●=16   ◐=12

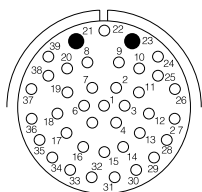

20-39

37-#20, 2-#16

LAYOUT  
# OF CONTACTS  
SERVICE RATING

I

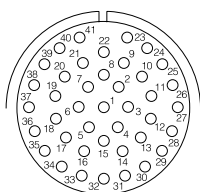

20-41

41-#20

I

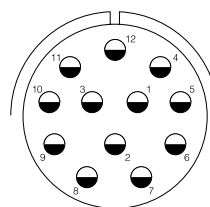

22-12

12-#12

I

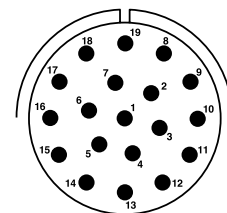

22-19

19-#16

I

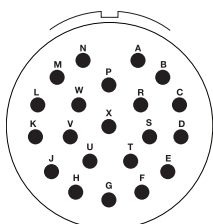

22-21

21-#16

LAYOUT  
# OF CONTACTS  
SERVICE RATING

I

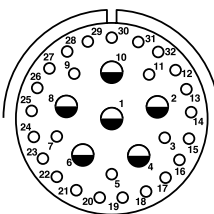

22-32

26-#20, 6-#12W

I

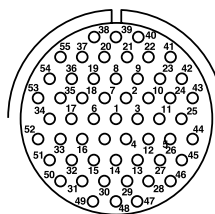

22-55

55-#20

I

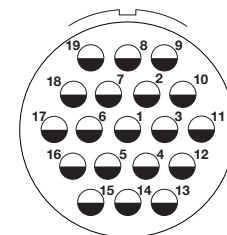

24-19

19-#12

I

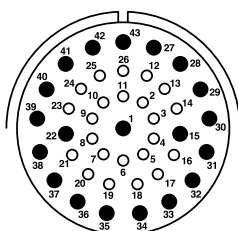

24-43

23-#20, 20-#16

LAYOUT  
# OF CONTACTS  
SERVICE RATING

I

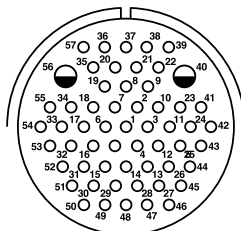

24-57

55-#20, 2-#12

I

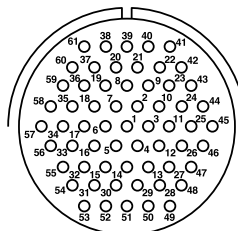

24-61

61-#20

I

## CONTACTS

### PINS

CONTACT SIZE	WIRE CRIMP SIZE RANGE	PIN PART NUMBER	COLOR BANDS			WIRE STRIP LENGTHS		WIRE INSULATION SEALING RANGE		WIRE HOLE FILLER	WIRE HOLE FILLER COLOR
			1	2	3	IN	MM	IN	MM		
20	20,22,24	M39029/5-115	Brown	Brown	Green	0.1875	4.77	.040/.083	1.02/2.11	MS27488-20-2	Red
16	16,18,20	M39029/5-116	Brown	Brown	Blue	0.2812	7.14	.053/.103	1.35/2.62	MS27488-16-2	Blue
12	12 & 14	M39029/5-118	Brown	Brown	Grey	0.2812	7.14	.097/.158	2.46/4.01	MS27488-12-2	Yellow

Insert head first, trim excess



### SOCKETS

CONTACT SIZE	WIRE CRIMP SIZE RANGE	SOCKET PART NUMBER	COLOR BANDS			WIRE STRIP LENGTHS		WIRE INSULATION SEALING RANGE		WIRE HOLE FILLER	WIRE HOLE FILLER COLOR
			1	2	3	IN	MM	IN	MM		
20	20,22,24	M39029/5-115	Brown	Brown	Green	0.1875	4.77	.040/.083	1.02/2.11	MS27488-20-2	Red
16	16,18,20	M39029/5-116	Brown	Brown	Blue	0.2812	7.14	.053/.103	1.35/2.62	MS27488-16-2	Blue
12	12 & 14	M39029/5-118	Brown	Brown	Grey	0.2812	7.14	.097/.158	2.46/4.01	MS27488-12-2	Yellow

Insert head first, trim excess



PINS

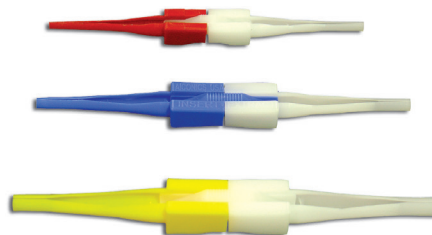

CONTACT SIZE	HAND-CRIMP TOOL	POWER-CRIMP TOOL	TURRET HEADS	USE LOCATOR COLOR	METAL		PLASTIC		
					INSERTION TOOL	EXTRACTION TOOL	INSERTION/EXTRACTION TOOL	INSERTION TIP COLOR	EXTRACTION TIP COLOR
20	M22520/1-01	WA27FH	M22520/1-02	Red	DAK83-20B	DRK83-20B	M81969/14-11	Red	White
16	M22520/1-01	WA27FH	M22520/1-02	Blue	DAK83-16B	DRK83-16B	M81969/14-03	Blue	White
12	M22520/1-01	WA27FH	M22520/1-02	Yellow	DAK83-12B	DRK83-12B	M81969/14-04	Yellow	White

SOCKETS

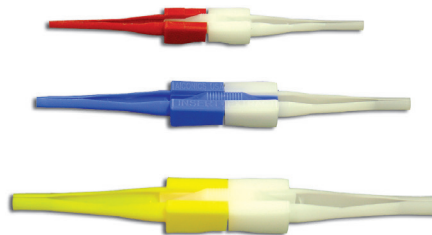

CONTACT SIZE	HAND-CRIMP TOOL	POWER-CRIMP TOOL	TURRET HEADS	USE LOCATOR COLOR	METAL		PLASTIC		
					INSERTION TOOL	EXTRACTION TOOL	INSERTION/EXTRACTION TOOL	INSERTION TIP COLOR	EXTRACTION TIP COLOR
20	M22520/1-01	WA27FH	M22520/1-02	Red	DAK83-20B	DRK83-20B	M81969/14-11	Red	White
16	M22520/1-01	WA27FH	M22520/1-02	Blue	DAK83-16B	DRK83-16B	M81969/14-03	Blue	White
12	M22520/1-01	WA27FH	M22520/1-02	Yellow	DAK83-12B	DRK83-12B	M81969/14-04	Yellow	White

## DIMENSIONS

### PLUG

**M83723/75, /76, /77, /78**  
**DL66R**

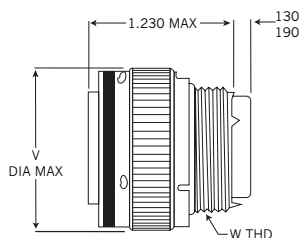

SHELL SIZE	V DIA. MAX.	W THREAD CLASS 2A
8	0.782 (19.86)	.5000-20 UNF
10	0.926 (23.52)	.6250-24 UNEF
12	1.043 (26.49)	.7500-20 UNEF
14	1.183 (30.04)	.8750-20 UNEF
16	1.305 (33.14)	1.000-20 UNEF
18	1.391 (35.33)	1.0625-18 UNEF
20	1.531 (38.88)	1.1875-18 UNEF
22	1.656 (42.06)	1.3125-18 UNEF
24	1.777 (45.13)	1.4375-18 UNEF

### FLANGE MOUNT

**M83723/71 & M83723/72**  
**DL60R**

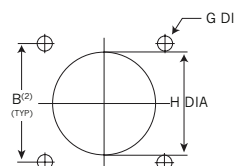
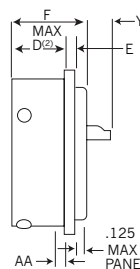
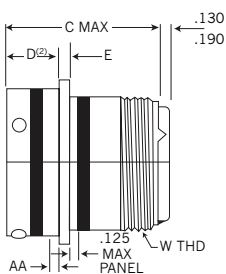
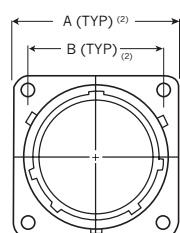

SHELL SIZE	AA MAX. PANEL THICKNESS		A MAX.	B +/- .005 (+/- 1.27)	C MAX.	D +/- .010 (+/- .254)	E +/- .016 (+/- .406)	W THREAD CLASS 2A	G +/- .005 (+/- .127)	H DIA. +/- .005 (+/- .127)
	.087 (2.21)	.118 (3.00)								
8	.087 (2.21)	.118 (3.00)	.828 (21.0)	.594 (15.1)	1.300 (33.02)	.781 (18.24)	.062 (1.6)	.5000-20 UNF	0.120 (3.05)	0.568 (14.42)
10	.087 (2.21)	.118 (3.00)	.954 (24.2)	.719 (18.3)	1.300 (33.02)	.781 (18.24)	.062 (1.6)	.6250-24 UNEF	0.120 (3.05)	0.685 (17.39)
12	.087 (2.21)	.118 (3.00)	1.047 (26.6)	.812 (20.6)	1.300 (33.02)	.781 (18.24)	.062 (1.6)	.7500-20 UNEF	0.120 (3.05)	0.864 (21.94)
14	.087 (2.21)	.118 (3.00)	1.141 (29.0)	.906 (23.0)	1.300 (33.02)	.781 (18.24)	.062 (1.6)	.8750-20 UNEF	0.120 (3.05)	0.989 (25.12)
16	.087 (2.21)	.118 (3.00)	1.234 (31.3)	.969 (24.6)	1.300 (33.02)	.781 (18.24)	.062 (1.6)	1.000-20 UNEF	0.120 (3.05)	1.113 (28.27)
18	.087 (2.21)	.118 (3.00)	1.328 (33.7)	1.062 (27.0)	1.300 (33.02)	.781 (18.24)	.062 (1.6)	1.0625-18 UNEF	0.120 (3.05)	1.238 (31.44)
20	.212 (5.38)	.212 (5.38)	1.453 (36.9)	1.156 (29.4)	1.300 (33.02)	.781 (18.24)	.094 (2.4)	1.1875-18 UNEF	0.120 (3.05)	1.363 (34.62)
22	.212 (5.38)	.212 (5.38)	1.578 (40.1)	1.250 (31.8)	1.300 (33.02)	.781 (18.24)	.094 (2.4)	1.3125-18 UNEF	0.120 (3.05)	1.488 (37.79)
24	.212 (5.38)	.212 (5.38)	1.703 (43.3)	1.375 (34.9)	1.300 (33.02)	.781 (18.24)	.094 (2.4)	1.4375-18 UNEF	0.147 (3.73)	1.615 (41.02)

All dimensions in inches (millimeters in parenthesis)

JAM NUT RECEPTACLE

M83723/73 & M83723/74  
DL64R

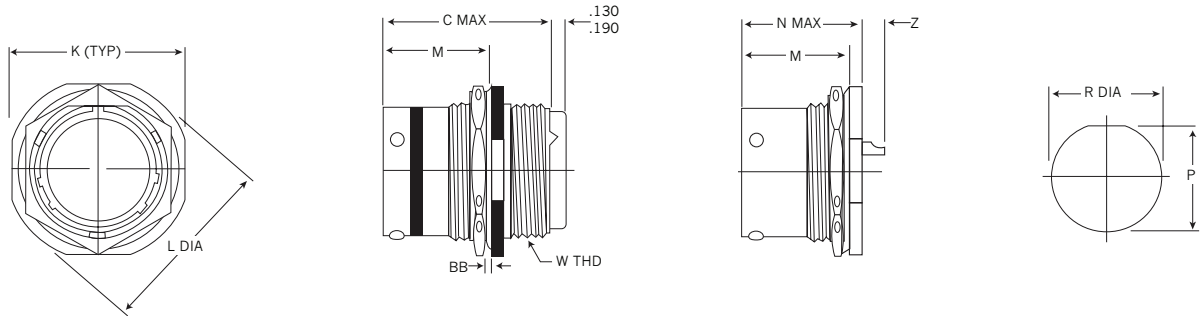

SHELL SIZE	BB MAX. PANEL	K MAX.	L +/- .016 (+/- .406)	M +/- .010 (+/- .254)	C MAX.	W THREAD CLASS 2A
8	.187 (4.75)	.979 (24.87)	1.063 (26.99)	.771 (19.58)	1.300 (33.02)	.5000-20 UNF
10	.187 (4.75)	1.104 (28.04)	1.188 (30.16)	.771 (19.58)	1.300 (33.02)	.6250-24 UNEF
12	.187 (4.75)	1.291 (32.79)	1.378 (34.94)	.771 (19.58)	1.300 (33.02)	.7500-20 UNEF
14	.187 (4.75)	1.391 (35.33)	1.501 (38.11)	.771 (19.58)	1.300 (33.02)	.8750-20 UNEF
16	.187 (4.75)	1.516 (38.51)	1.626 (41.29)	.771 (19.58)	1.300 (33.02)	1.000-20 UNEF
18	.187 (4.75)	1.641 (41.68)	1.751 (44.46)	.771 (19.58)	1.300 (33.02)	1.0625-18 UNEF
20	.250 (6.35)	1.766 (44.86)	1.939 (49.24)	.771 (19.58)	1.300 (33.02)	1.1875-18 UNEF
22	.250 (6.35)	1.954 (49.63)	2.063 (52.39)	.771 (19.58)	1.300 (33.02)	1.3125-18 UNEF
24	.219 (5.56)	2.079 (52.81)	2.188 (55.56)	.771 (19.58)	1.300 (33.02)	1.4375-18 UNEF

P	R DIA.
.605 (15.37)	.635 (16.13)
.730 (18.54)	.760 (19.30)
.917 (23.29)	.947 (24.05)
.980 (24.89)	1.010 (25.65)
1.105 (28.07)	1.135 (28.83)
1.229 (31.22)	1.260 (32.00)
1.354 (34.39)	1.385 (35.18)
1.479 (37.57)	1.510 (38.35)
1.604 (40.74)	1.635 (41.53)

All dimensions in inches (millimeters in parenthesis)

DUMMY RECEPTACLES, DUST CAPS & PLUG CAPS



SHELL SIZE	DUMMY RECEPTACLES OLIVE DRAB OVER CADMIUM PLATED	METAL DUSTCAP	
		FOR PLUGS	FOR RECEPTACLE FLANGED WITH SASH CHAIN
8	M83723/61-28*	M83723/59-28*	M83723/60-28*
10	M83723/61-210*	M83723/59-210*	M83723/60-210*
12	M83723/61-212*	M83723/59-212*	M83723/60-212*
14	M83723/61-214*	M83723/59-214*	M83723/60-214*
16	M83723/61-216*	M83723/59-216*	M83723/60-216*
18	M83723/61-218*	M83723/59-218*	M83723/60-218*
20	M83723/61-220*	M83723/59-220*	M83723/60-220*
22	M83723/61-222*	M83723/59-222*	M83723/60-222*
24	M83723/61-224*	M83723/59-224*	M83723/60-224*

\*Select plating code to match connector plating

A = Black Anodized

R = Electroless nickel

W = Olive drab chromate over cadmium over electroless nickel (500-hour salt spray)

STANDARD CABLE CLAMPS

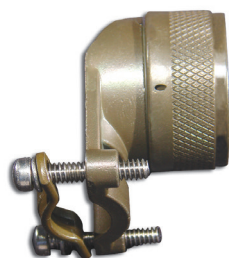

SHELL SIZE	STRAIGHT CLAMP		90°		CABLE ENTRY	
	LOW COST	SELF-LOCKING	LOW COST	SELF-LOCKING	MAX	MIN
8	M85049/52-1-8*	M85049/52S8*	M85049/51-1-8*	M85049/51S8*	.204 (5.18)	.125 (3.18)
10	M85049/52-1-10*	M85049/52S10*	M85049/51-1-10*	M85049/51S10*	.286 (7.26)	.187 (4.75)
12	M85049/52-1-12*	M85049/52S12*	M85049/51-1-12*	M85049/51S12*	.416 (10.57)	.291 (7.39)
14	M85049/52-1-14*	M85049/52S14*	M85049/51-1-14*	M85049/51S14*	.476 (12.09)	.351 (8.92)
16	M85049/52-1-16*	M85049/52S16*	M85049/51-1-16*	M85049/51S16*	.625 (15.88)	.501 (12.72)
18	M85049/52-1-18*	M85049/52S18*	M85049/51-1-18*	M85049/51S18*	.706 (17.93)	.518 (13.16)
20	M85049/52-1-20*	M85049/52S20*	M85049/51-1-20*	M85049/51S20*	.831 (21.11)	.581 (14.76)
22	M85049/52-1-22*	M85049/52S22*	M85049/51-1-22*	M85049/51S22*	.956 (24.28)	.644 (16.36)
24	M85049/52-1-24*	M85049/52S24*	M85049/51-1-24*	M85049/51S24*	1.081 (27.46)	.706 (17.93)

\*Select plating code to match connector plating

A = Black Anodized

R = Electroless nickel

W = Olive drab chromate over cadmium over electroless nickel (500-hour salt spray)

All dimensions in inches (millimeters in parenthesis)

## STANDARD CABLE CLAMPS

	DESCRIPTION	PART NUMBER PREFIX	STRAIGHT	90°	45°
	Heat Shrink Boot Adapter	M85049/60	X		
	Environmental	M85049/7			X
		M85049/9		X	
		M85049/11	X		
	EMI/RFI Non- Environmental	M85049/23			X
		M85049/24		X	
		M85049/25	X		
	EMI/RFI Environmental	M85049/6			X
		M85049/8		X	
		M85049/10	X		
	EMI/RFI Crimp Ring	M85049/26	X		
	EMI/RFI Banding	M85049/82	X		
		M85049/83			X
		M85049/84		X	
	Cable Tie	M85049/55		X	
		M85049/53	X		
		M85049/54			X
	Wire Seal Compression Nuts "E"	M85049/31	X		

NOTE: If military-standard versions won't work for your applications, please contact us with your requirements.



**WIRE STRIPPING AND CONTACT CRIMPING**

correct crimp



incorrect crimp



**STEP 1:** Strip wires. See above for correct strip length for contact. Insert wire into rear of contact. Wire insulation must push against rear of contact. Wire must be visible through inspection hole.

**STEP 2:** Use M22520/1-01 crimp tool with proper crimp locator M22520/1-02.

CONTACT SIZE	COLOR
20	Red
16	Blue
12	Yellow

**STEP 3:** Insert contact and wire into tool jaws. To crimp, squeeze handles together fully until ratchet releases and allows handles to expand; otherwise, contact cannot be extracted from tool jaws. Maintain slight insertion pressure on wire while crimping contact to wire.\*

\*IMPORTANT NOTE: Microsection the contact to verify crimp quality.

**CONTACT INSERTION**

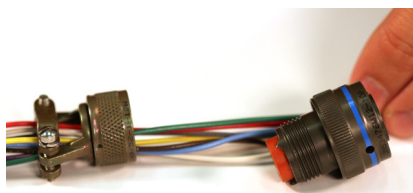

**STEP 1:** Remove backshell and put wired contacts through cable clamp opening.

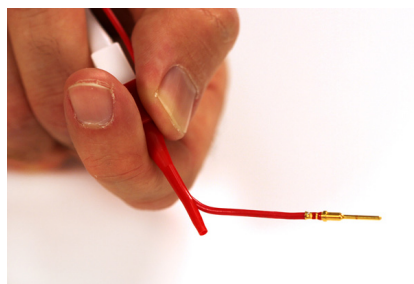

**STEP 2:** Use colored end of CIET tool for insertion. Place wire into tool at large opening. To facilitate contact insertion, a minimum six inches of free wire is recommended.

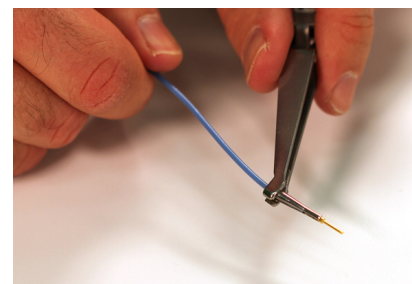

**STEP 3:** Slide tool on wire while holding thumb against wire at opening. Wire will slip into tool.

**CONTACT INSERTION (CONT.)**



**STEP 4:** With tool pressed against shoulder of contact, starting at the center cavity, insert wired contact and tool into properly-identified cavity at rear of plug with firm, even pressure. Do not use excessive pressure.

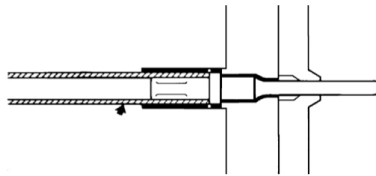

**STEP 5:** When contact bottoms, a slight click can be heard as tines of metal retaining clip snap into place behind contact shoulder.

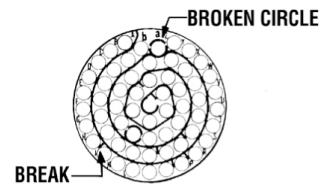

**STEP 6:** Check face of plug or receptacle for proper contact installation. In socket inserts with a large number of contacts, cavities are identified in a spiral pattern. A projecting line from the spiral indicates omission of a letter; a broken circle around a cavity indicates transition between capitals, lower case and double letters.



**STEP 7:** Withdraw tool from rear of plug. To be sure that contact is locked, pull back lightly on wire. Then remove tool from wire and proceed with other contacts.



**STEP 8:** After all contacts are inserted, fill unwired cavities with sealing plugs (insert head first and leave end protruding for ease of removal), assemble backshell on rear of connector.

## CONTACT EXTRACTION

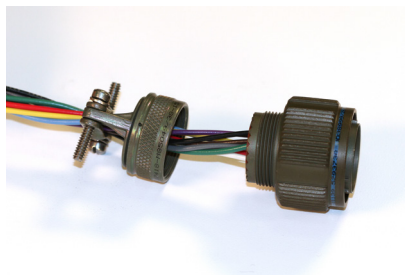

**STEP 1:** Remove hardware from plug or receptacle and slide hardware back along wire bundle.

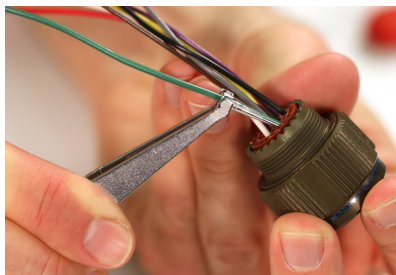

**STEP 2:** Using plastic or metal extraction tool with proper color code corresponding to contact size, place wire in tool.

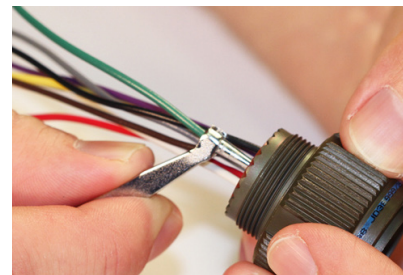

**STEP 3:** Insert tool into contact cavity until tool tip bottoms against the contact shoulder, expanding clip retaining tines.

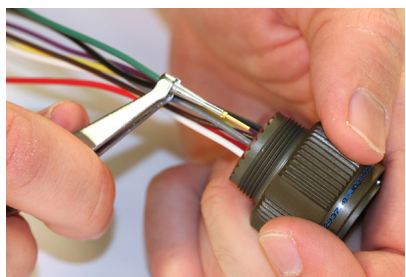

**STEP 4:** Hold wire firmly in tool and extract wired contact and tool. Repeat operation for all contacts to be extracted.

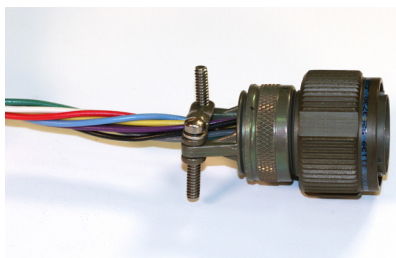

**STEP 5:** Fill any empty cavities with wire sealing plugs. Reassemble plug or receptacle hardware.

Note: DTS series shown.