



Chipsmall Limited consists of a professional team with an average of over 10 year of expertise in the distribution of electronic components. Based in Hongkong, we have already established firm and mutual-benefit business relationships with customers from,Europe,America and south Asia,supplying obsolete and hard-to-find components to meet their specific needs.

With the principle of “Quality Parts,Customers Priority,Honest Operation,and Considerate Service”,our business mainly focus on the distribution of electronic components. Line cards we deal with include Microchip,ALPS,ROHM,Xilinx,Pulse,ON,Everlight and Freescale. Main products comprise IC,Modules,Potentiometer,IC Socket,Relay,Connector.Our parts cover such applications as commercial,industrial, and automotives areas.

We are looking forward to setting up business relationship with you and hope to provide you with the best service and solution. Let us make a better world for our industry!



## Contact us

Tel: +86-755-8981 8866 Fax: +86-755-8427 6832

Email & Skype: info@chipsmall.com Web: www.chipsmall.com

Address: A1208, Overseas Decoration Building, #122 Zhenhua RD., Futian, Shenzhen, China



TITLE  
24  
COMPLIANCE



### PROJECT INFORMATION

Project Name \_\_\_\_\_

Catalog No. \_\_\_\_\_

Date \_\_\_\_\_



DLC7

Our DLC7 is the ideal system for providing continuous dimming control for 2-wire 0–10V dimming ballasts based on natural daylight. This control maintains constant, undisturbed, fluorescent light levels during peak use times. Through continuous monitoring of ambient light levels, the DLC7 dims the associated lighting fixtures to a user's predefined foot-candle setting. The DLC7 dimming photocell provides precise control of the actual amount of lighting on the work surface (e.g. desktop, floor) within its field of view. Measured light levels are converted into a linear, proportional, analog voltage that controls the ballast-dimming range. This achieves maximum energy savings by efficiently blending natural and artificial light to maintain a comfortable visual environment.

The sensor head adjustment sets the maximum output of the controlled ballast. The sensor also provides a short and long delay. The short delay provides faster sensor response. The long delay slows the sensor response and maintains a more stable signal to the ballast, accommodating for brief changes in light due to passing clouds.

### PRODUCT FEATURES

- Controls 2-wire 0–10V dimming ballasts
- Light-sensitivity range of 0–500FC
- Selectable 3- or 8-second dimming rate
- Multiple calibration options
- Low-profile design
- Five-year limited warranty
- Low voltage device: 24 Vdc

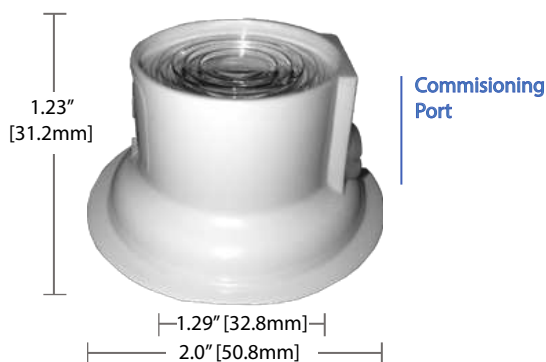

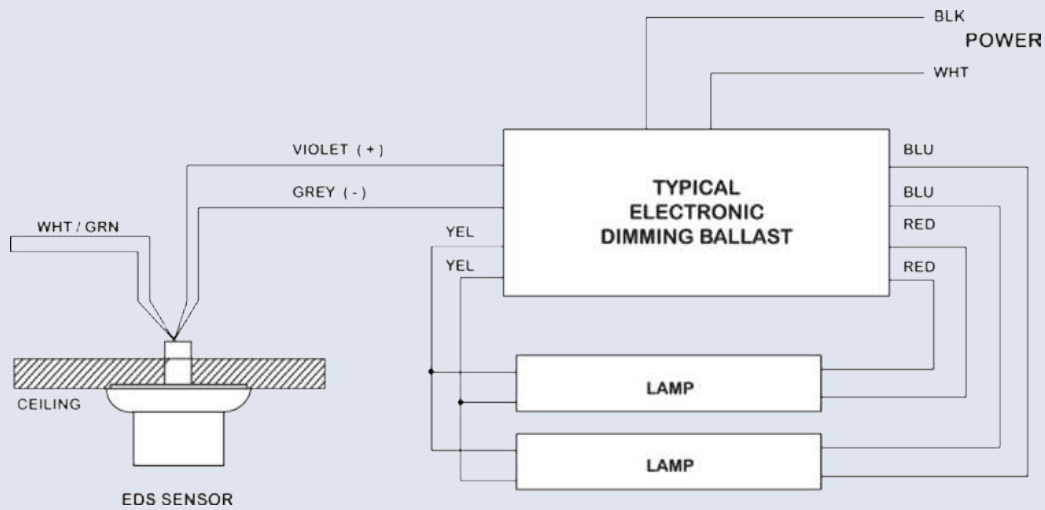

## General Specifications

Accuracy	+/-1% @ 70°F (21°C); Derated to +/-5% when above 120°F or below 50°F (18° to 49°C)
Operating environment	-40°F to 140°F (-40°C to 60°C)
Sensitivity ranges	0–500FC
Adjustment range	10–140FC
Input voltage	10V (supplied by ballast)
Current:	Sink up to 25mA
Output voltage	1V (light) - 10 V (dark)
Wire leads	22 gauge Gray and violet to the Advance ballast White-green 2-wire loop cut for 10-second delay. Leave intact for 20-second delay to ballast
Sensor type	Blue enhanced photodiode
Size	Base diameter: 2.00" (50.8mm) Sensor diameter: 1.29" (32.8mm) Height: 1.23" (31.2mm)
Mounting	Mounting hole: 3/8" (9.5mm) Mounting medium: 3M™ double adhesive tape
Construction	Sensor housing meets flame-retardant requirements of UL standard 94HB
Certifications	ETL/UL 916
Warranty	Five-year limited

## Ordering Information

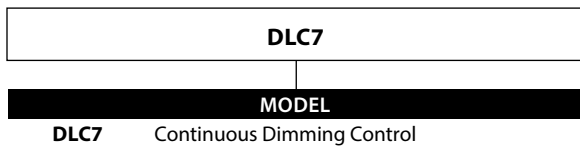

**HUBBELL**  
Control Solutions