



Chipsmall Limited consists of a professional team with an average of over 10 year of expertise in the distribution of electronic components. Based in Hongkong, we have already established firm and mutual-benefit business relationships with customers from,Europe,America and south Asia,supplying obsolete and hard-to-find components to meet their specific needs.

With the principle of “Quality Parts,Customers Priority,Honest Operation,and Considerate Service”,our business mainly focus on the distribution of electronic components. Line cards we deal with include Microchip,ALPS,ROHM,Xilinx,Pulse,ON,Everlight and Freescale. Main products comprise IC,Modules,Potentiometer,IC Socket,Relay,Connector.Our parts cover such applications as commercial,industrial, and automotives areas.

We are looking forward to setting up business relationship with you and hope to provide you with the best service and solution. Let us make a better world for our industry!



## Contact us

Tel: +86-755-8981 8866 Fax: +86-755-8427 6832

Email & Skype: info@chipsmall.com Web: www.chipsmall.com

Address: A1208, Overseas Decoration Building, #122 Zhenhua RD., Futian, Shenzhen, China





**MICROCHIP**

---

**F1 LV Evaluation Platform  
Motor Control Add-Ons  
User's Guide**

---

**Note the following details of the code protection feature on Microchip devices:**

- Microchip products meet the specification contained in their particular Microchip Data Sheet.
- Microchip believes that its family of products is one of the most secure families of its kind on the market today, when used in the intended manner and under normal conditions.
- There are dishonest and possibly illegal methods used to breach the code protection feature. All of these methods, to our knowledge, require using the Microchip products in a manner outside the operating specifications contained in Microchip's Data Sheets. Most likely, the person doing so is engaged in theft of intellectual property.
- Microchip is willing to work with the customer who is concerned about the integrity of their code.
- Neither Microchip nor any other semiconductor manufacturer can guarantee the security of their code. Code protection does not mean that we are guaranteeing the product as "unbreakable."

Code protection is constantly evolving. We at Microchip are committed to continuously improving the code protection features of our products. Attempts to break Microchip's code protection feature may be a violation of the Digital Millennium Copyright Act. If such acts allow unauthorized access to your software or other copyrighted work, you may have a right to sue for relief under that Act.

---

Information contained in this publication regarding device applications and the like is provided only for your convenience and may be superseded by updates. It is your responsibility to ensure that your application meets with your specifications. MICROCHIP MAKES NO REPRESENTATIONS OR WARRANTIES OF ANY KIND WHETHER EXPRESS OR IMPLIED, WRITTEN OR ORAL, STATUTORY OR OTHERWISE, RELATED TO THE INFORMATION, INCLUDING BUT NOT LIMITED TO ITS CONDITION, QUALITY, PERFORMANCE, MERCHANTABILITY OR FITNESS FOR PURPOSE. Microchip disclaims all liability arising from this information and its use. Use of Microchip devices in life support and/or safety applications is entirely at the buyer's risk, and the buyer agrees to defend, indemnify and hold harmless Microchip from any and all damages, claims, suits, or expenses resulting from such use. No licenses are conveyed, implicitly or otherwise, under any Microchip intellectual property rights.

**Trademarks**

The Microchip name and logo, the Microchip logo, dsPIC, KEELOQ, KEELOQ logo, MPLAB, PIC, PICmicro, PICSTART, PIC<sup>32</sup> logo, rPIC and UNI/O are registered trademarks of Microchip Technology Incorporated in the U.S.A. and other countries.

FilterLab, Hampshire, HI-TECH C, Linear Active Thermistor, MXDEV, MXLAB, SEEVAL and The Embedded Control Solutions Company are registered trademarks of Microchip Technology Incorporated in the U.S.A.

Analog-for-the-Digital Age, Application Maestro, chipKIT, chipKIT logo, CodeGuard, dsPICDEM, dsPICDEM.net, dsPICworks, dsSPEAK, ECAN, ECONOMONITOR, FanSense, HI-TIDE, In-Circuit Serial Programming, ICSP, Mindi, MiWi, MPASM, MPLAB Certified logo, MPLIB, MPLINK, mTouch, Omniscient Code Generation, PICC, PICC-18, PICDEM, PICDEM.net, PICkit, PICtail, REAL ICE, rLAB, Select Mode, Total Endurance, TSHARC, UniWinDriver, WiperLock and ZENA are trademarks of Microchip Technology Incorporated in the U.S.A. and other countries.

SQTP is a service mark of Microchip Technology Incorporated in the U.S.A.

All other trademarks mentioned herein are property of their respective companies.

© 2012, Microchip Technology Incorporated, Printed in the U.S.A., All Rights Reserved.

 Printed on recycled paper.

ISBN: 9781620761236

**QUALITY MANAGEMENT SYSTEM  
CERTIFIED BY DNV  
= ISO/TS 16949 =**

*Microchip received ISO/TS-16949:2009 certification for its worldwide headquarters, design and wafer fabrication facilities in Chandler and Tempe, Arizona; Gresham, Oregon and design centers in California and India. The Company's quality system processes and procedures are for its PIC<sup>®</sup> MCUs and dsPIC<sup>®</sup> DSCs, KEELOQ<sup>®</sup> code hopping devices, Serial EEPROMs, microperipherals, nonvolatile memory and analog products. In addition, Microchip's quality system for the design and manufacture of development systems is ISO 9001:2000 certified.*



# F1 LV EVALUATION PLATFORM MOTOR CONTROL ADD-ONS

## Table of Contents

### Chapter 1. F1 LV Evaluation Platform Overview

1.1	Introduction .....	13
1.2	Hardware Overview .....	13
1.2.1	Evaluation Platforms .....	13
1.2.2	Add-on Boards .....	13
1.2.3	USB Interface .....	14
1.2.4	Add-on Board Power .....	14
1.2.5	Add-on Board Memory .....	14
1.3	PC Software Overview .....	14
1.4	Using the F1LVDemo Control Software .....	17
1.4.1	Software Updates .....	17
1.4.2	Serial Link .....	17
1.4.3	Connecting the F1 LV Evaluation Platform to the Add-on Board .....	17
1.4.4	Connecting the F1 LV Evaluation Platform to the PC .....	17
1.4.5	Open Versus Closed Loop .....	18
1.4.6	Changing Motor Parameters .....	18
1.4.7	Saving and Restoring Motor Parameters .....	18
1.4.8	Hints for Optimum Performance .....	19
1.4.9	Header File Versus GUI Motor Parameters .....	19

### Chapter 2. The BLDC Add-on Board

2.1	Overview .....	21
2.1.1	Features .....	21
2.1.2	What's Included .....	21
2.1.3	Reference Documents .....	22
2.2	Board Setup .....	22
2.3	Hardware .....	22
2.3.1	General Architecture .....	22
2.3.2	Attaching the Motor .....	23
2.3.3	Power-Up .....	23
2.3.4	Power Stage .....	23
2.3.5	Protection .....	24
2.3.6	Speed Control .....	24
2.4	Demo Software .....	24
2.4.1	Introduction .....	24
2.4.2	The Motor Control GUI Application .....	24
2.4.3	BLDC Parameter Optimization .....	25

### Chapter 3. The Brushed DC Add-on Board

3.1	Getting Started .....	29
3.1.1	Overview .....	29
3.1.2	Features .....	29
3.1.3	What's Included .....	29

# F1 LV Evaluation Platform Motor Control Add-Ons

---

3.1.4	Reference Documents .....	30
3.2	Board Setup .....	30
3.3	Hardware .....	30
3.3.1	General Architecture .....	30
3.3.2	Attaching the Motor .....	31
3.3.3	Power-Up .....	31
3.3.4	Power Stage .....	31
3.3.5	Protection .....	32
3.3.6	UNI/O® Memory Chip .....	32
3.3.7	Speed Control .....	32
3.4	Demo Software .....	32
3.4.1	Introduction .....	32
3.4.2	The Motor Control GUI Application .....	32

## Chapter 4. The Bipolar Stepper Add-on Board

4.1	Getting Started .....	33
4.1.1	Overview .....	33
4.2	Features .....	33
4.2.1	What's Included .....	33
4.2.2	Reference Documents .....	33
4.3	Getting Started .....	34
4.4	Hardware .....	34
4.4.1	General Architecture .....	34
4.4.2	Attaching the Motor .....	35
4.4.3	Power-Up .....	35
4.4.4	Power Stage .....	35
4.4.5	Protection .....	36
4.4.6	UNI/O® Memory Chip .....	36
4.4.7	Speed Control .....	36
4.4.8	Current Control .....	36
4.5	Demo Software .....	37
4.5.1	Introduction .....	37
4.5.2	The Motor Control GUI Application .....	37
4.6	Optimizing Stepper Motor Parameters .....	38
4.6.1	Stepper Motor Closed-Loop Drive Overview .....	38
4.6.2	Optimizing DUTY_SCALE and SPEED_SCALING_CONST .....	39

## Chapter 5. The Unipolar Stepper Add-on Board

5.1	Getting Started .....	41
5.1.1	Overview .....	41
5.1.2	Features .....	41
5.1.3	What's Included .....	41
5.1.4	Reference Documents .....	42
5.2	Getting Started .....	42
5.3	Hardware .....	42
5.3.1	General Architecture .....	42
5.3.2	Attaching the Motor .....	43
5.3.3	Power-Up .....	43
5.3.4	Power Stage .....	43
5.3.5	Protection .....	44



---

5.3.6	UNI/O® Memory Chip .....	44
5.3.7	Speed Control .....	44
5.3.8	Current Control .....	44
5.4	Demo Software .....	45
5.4.1	Introduction .....	45
5.4.2	The Motor Control GUI Application .....	45
5.5	Optimizing Stepper Motor Parameters .....	46
5.5.1	Stepper Motor Closed-Loop Drive Overview .....	46
5.5.2	Optimizing DUTY_SCALE and SPEED_SCALING_CONST .....	47

## **Appendix A. Board Layout and Schematics**

A.1	Introduction .....	49
-----	--------------------	----

## **Appendix B. Conversion Factors**

B.1	Conversion Factor Derivations .....	55
B.2	Start-up: Speed .....	55
B.3	Slow Step .....	55
B.4	Stepper Run and Stop Percentages .....	56
B.5	Degrees Per Step .....	56
B.6	Stepper: Min and Max Duty Percent .....	56
B.7	Constants Derived From Stepper Parameters .....	56
B.7.1	DUTY_SCALE Constant .....	56
B.7.2	SPEED_SCALING_CONST Constant .....	57
B.8	uStep Table .....	57

# F1 LV Evaluation Platform Motor Control Add-Ons

---

NOTES:

---

---

**Preface**

---

---

**NOTICE TO CUSTOMERS**

All documentation becomes dated, and this manual is no exception. Microchip tools and documentation are constantly evolving to meet customer needs, so some actual dialogs and/or tool descriptions may differ from those in this document. Please refer to our web site ([www.microchip.com](http://www.microchip.com)) to obtain the latest documentation available.

Documents are identified with a “DS” number. This number is located on the bottom of each page, in front of the page number. The numbering convention for the DS number is “DSXXXXA”, where “XXXX” is the document number and “A” is the revision level of the document.

For the most up-to-date information on development tools, see the MPLAB® IDE online help. Select the Help menu, and then Topics to open a list of available online help files.

**INTRODUCTION**

This chapter contains general information that will be useful to know before using the F1 LV Evaluation Platform Motor Control Add-ons User’s Guide. Items discussed in this chapter include:

- [Document Layout](#)
- [Conventions Used in this Guide](#)
- [Warranty Registration](#)
- [Recommended Reading](#)
- [The Microchip Web Site](#)
- [Development Systems Customer Change Notification Service](#)
- [Customer Support](#)
- [Document Revision History](#)

**DOCUMENT LAYOUT**

This document describes how to use the F1 LV Evaluation Platform Motor Control Add-ons User’s Guide as a development tool to emulate and debug firmware on a target board. The manual layout is as follows:

- **Chapter 1. “F1 LV Evaluation Platform Overview”**
- **Chapter 2. “The BLDC Add-on Board”**
- **Chapter 3. “The Brushed DC Add-on Board”**
- **Chapter 4. “The Bipolar Stepper Add-on Board”**
- **Chapter 5. “The Unipolar Stepper Add-on Board”**
- **Appendix A. “Board Layout and Schematics”**
- **Appendix B. “Conversion Factors”**



# F1 LV Evaluation Platform Motor Control Add-Ons

## CONVENTIONS USED IN THIS GUIDE

This manual uses the following documentation conventions:

### DOCUMENTATION CONVENTIONS

Description	Represents	Examples
<b>Arial font:</b>		
Italic characters	Referenced books	<i>MPLAB® IDE User's Guide</i>
	Emphasized text	...is the <i>only</i> compiler...
Initial caps	A window	the Output window
	A dialog	the Settings dialog
	A menu selection	select Enable Programmer
Quotes	A field name in a window or dialog	"Save project before build"
Underlined, italic text with right angle bracket	A menu path	<u><i>File&gt;Save</i></u>
Bold characters	A dialog button	Click <b>OK</b>
	A tab	Click the <b>Power</b> tab
N'Rnnnn	A number in verilog format, where N is the total number of digits, R is the radix and n is a digit.	4'b0010, 2'hF1
Text in angle brackets < >	A key on the keyboard	Press <Enter>, <F1>
<b>Courier New font:</b>		
Plain Courier New	Sample source code	#define START
	Filenames	autoexec.bat
	File paths	c:\mcc18\h
	Keywords	_asm, _endasm, static
	Command-line options	-Opa+, -Opa-
	Bit values	0, 1
	Constants	0xFF, 'A'
Italic Courier New	A variable argument	<i>file.o</i> , where <i>file</i> can be any valid filename
Square brackets [ ]	Optional arguments	mcc18 [options] <i>file</i> [options]
Curly brackets and pipe character: {   }	Choice of mutually exclusive arguments; an OR selection	errorlevel {0 1}
Ellipses...	Replaces repeated text	var_name [, var_name...]
	Represents code supplied by user	void main (void) { ... }

## WARRANTY REGISTRATION

Please complete the enclosed Warranty Registration Card and mail it promptly. Sending in the Warranty Registration Card entitles users to receive new product updates. Interim software releases are available at the Microchip web site.

## RECOMMENDED READING

This user's guide describes how to use the F1 LV Evaluation Platform Motor Control Add-ons User's Guide. Other useful documents are listed below. The following Microchip documents are available and recommended as supplemental reference resources.

### **Readme for F1 LV Evaluation Platform Motor Control Add-ons User's Guide**

For the latest information on using F1 LV Evaluation Platform Motor Control Add-ons User's Guide, read the "Readme for F1 LV Evaluation Platform Motor Control Add-ons User's Guide.txt" file (an ASCII text file) in the Readmes subdirectory of the MPLAB IDE installation directory. The Readme file contains update information and known issues that may not be included in this user's guide.

### **Readme Files**

For the latest information on using other tools, read the tool-specific Readme files in the Readmes subdirectory of the MPLAB IDE installation directory. The Readme files contain update information and known issues that may not be included in this user's guide.

# F1 LV Evaluation Platform Motor Control Add-Ons

---

## THE MICROCHIP WEB SITE

Microchip provides online support via our web site at [www.microchip.com](http://www.microchip.com). This web site is used as a means to make files and information easily available to customers. Accessible by using your favorite Internet browser, the web site contains the following information:

- **Product Support** – Data sheets and errata, application notes and sample programs, design resources, user's guides and hardware support documents, latest software releases and archived software
- **General Technical Support** – Frequently Asked Questions (FAQs), technical support requests, online discussion groups, Microchip consultant program member listing
- **Business of Microchip** – Product selector and ordering guides, latest Microchip press releases, listing of seminars and events, listings of Microchip sales offices, distributors and factory representatives

## DEVELOPMENT SYSTEMS CUSTOMER CHANGE NOTIFICATION SERVICE

Microchip's customer notification service helps keep customers current on Microchip products. Subscribers will receive e-mail notification whenever there are changes, updates, revisions or errata related to a specified product family or development tool of interest.

To register, access the Microchip web site at [www.microchip.com](http://www.microchip.com), click on Customer Change Notification and follow the registration instructions.

The Development Systems product group categories are:

- **Compilers** – The latest information on Microchip C compilers and other language tools. These include the HI-TECH C<sup>®</sup> C16, MPLAB C18 and MPLAB C30 C compilers; MPASM<sup>™</sup> and MPLAB ASM30 assemblers; MPLINK<sup>™</sup> and MPLAB LINK30 object linkers; and MPLIB<sup>™</sup> and MPLAB LIB30 object librarians.
- **In-Circuit Debuggers** – The latest information on the Microchip in-circuit debugger, MPLAB ICD 2, MPLAB ICD 3, PICKit<sup>™</sup> 3.
- **MPLAB<sup>®</sup> IDE** – The latest information on Microchip MPLAB IDE, the Windows<sup>®</sup> Integrated Development Environment for development systems tools. This list is focused on the MPLAB IDE, MPLAB SIM simulator, MPLAB IDE Project Manager and general editing and debugging features.
- **Programmers** – The latest information on Microchip programmers. These include the MPLAB PM3 device programmers and PICKit<sup>™</sup> 3 development programmers.

## CUSTOMER SUPPORT

Users of Microchip products can receive assistance through several channels:

- Distributor or Representative
- Local Sales Office
- Field Application Engineer (FAE)
- Technical Support

Customers should contact their distributor, representative or field application engineer (FAE) for support. Local sales offices are also available to help customers. A listing of sales offices and locations is included in the back of this document.

Technical support is available through the web site at: <http://support.microchip.com>

## DOCUMENT REVISION HISTORY

### Revision A (March 2012)

- Initial Release of this Document.

# F1 LV Evaluation Platform Motor Control Add-Ons

---

NOTES:

## Chapter 1. F1 LV Evaluation Platform Overview

### 1.1 INTRODUCTION

This user's guide offers a quick start-up and eventual troubleshooting for the motor control add-ons used together with the F1 LV Evaluation Platform. For more details regarding the supported applications, control algorithms, hardware and software support, please visit the reference sections inside this user's guide.

### 1.2 HARDWARE OVERVIEW

#### 1.2.1 Evaluation Platforms

The F1 Evaluation and F1 LV Evaluation Boards are stand-alone evaluation platforms for investigating the capabilities of the PIC16(L)F1XXX family of devices. F1 is an abbreviation for all PIC<sup>®</sup> microcontroller devices with the notation "F1" in the device number. All F1 devices are enhanced mid-range devices. Only enhanced mid-range devices have the F1 notation.

There are two development boards for evaluating the F1 devices:

- F1 Evaluation Platform with 44-pin PIC16LF1937 microcontroller
- F1 LV Evaluation Platform with 64-pin PIC16LF1947 microcontroller

This document refers primarily to the F1 LV Evaluation Platform.

The F1 LV Evaluation Platform is the second generation evaluation platform for the enhanced mid-range devices with more I/O pins and expanded capability. For more information about the F1 LV Evaluation Platform refer to DS41614, "F1 LV Evaluation Platform for Enhanced PIC<sup>®</sup> Microcontrollers User's Guide".

#### 1.2.2 Add-on Boards

Four motor control add-on boards are available for use in conjunction with the F1 LV Evaluation Platform. This document describes those boards and the companion control software for evaluating and optimizing motor control. The four motor control boards include:

**TABLE 1-1:**

Motor Type	ID Shown on Platform LCD	Part Number	F1 LV Eval	F1 Eval
Brushless DC	bldc	DM164130-2	Yes	Yes
Brushed DC	bdc	DM164130-6	Yes	No
Bipolar Stepper	bstp	DM164130-7	Yes	No
Unipolar Stepper	ustp	DM164130-8	Yes	No

The software and hardware interface of the F1 Evaluation Board supports only the BLDC Add-on Board. The software supplied and preloaded on the F1 LV Evaluation Platform supports all four of the add-on boards.

# F1 LV Evaluation Platform Motor Control Add-ons

---

## 1.2.3 USB Interface

The F1 LV Evaluation Platform includes a USB to serial interface. This provides the capability to control the motors in real time without entering Debug mode. PC control software communicates with the F1 LV Evaluation Platform software to create an integrated motor control evaluation system. The PC software and interface driver are available for free download from the Microchip web site at [www.microchip.com/F1Eval](http://www.microchip.com/F1Eval).

## 1.2.4 Add-on Board Power

When using an add-on board, the F1 LV Evaluation Platform power should be supplied from the add-on board. The J6 jumper option makes this connection. There is no jumper option to supply power to the add-on board from the F1 LV Evaluation Platform, because most of the platform power options do not have sufficient capacity. When power is applied to the F1 LV Evaluation Platform through the add-on board, then the UNI/O<sup>®</sup> memory is detected and read. The F1 LV Evaluation Platform software configures itself to operate the motor identified in the memory. This automatic configuration also applies to the PC control software.

## 1.2.5 Add-on Board Memory

Every add-on board, with one exception, includes a UNI/O memory device that contains:

- board ID
- board revision
- parameters associated with the motor supplied with the add-on board

When the F1 LV Evaluation Platform senses that an add-on board is attached, the initial display shows the motor type and add-on board revision. Motor speed can be controlled with either the potentiometer on the F1 LV Evaluation Platform or with the PC interface speed control. Additional motor capabilities are available through the PC control interface. These are described in more detail in the sections specific to each motor.

The first generation BLDC boards do not have a UNI/O memory. When the F1 LV Evaluation Platform does not detect a UNI/O memory, it then checks voltages on other selected J3 connections to determine if a BLDC circuit is present. When a BLDC board without UNI/O memory is detected, the motor parameters are then retrieved from the F1 LV Evaluation Platform EEPROM memory. The factory defaults for these parameters match those needed for the motor originally supplied with the BLDC board. If the parameters are modified for another motor, then the *File->RAM->EEPROM* option will save those parameters to the F1 LV Evaluation Platform EEPROM memory in lieu of the UNI/O memory.

The advantage that the UNI/O equipped boards have is that several different add-on boards can each support and remember the settings for a different motor. Various BLDC motors can be accommodated when working with the first generation BLDC Add-on Board, by saving and recalling the motor parameters to and from the PC disc storage with the *File->Save...* and *File->Open...* options.

## 1.3 PC SOFTWARE OVERVIEW

The F1LVDemo software is a Graphical User Interface (GUI) providing control of the motor speed and direction. The GUI also provides access to key parameters of the motor operation. The control parameters vary by motor type. Each parameter and method of optimization are described in detail in the motor sections of this document.

[Figure 1-1](#) and [Figure 1-2](#) show the front panel of the PC control GUI. Features of the control GUI are identified and described below.



# F1 LV Evaluation Platform Overview

FIGURE 1-1:

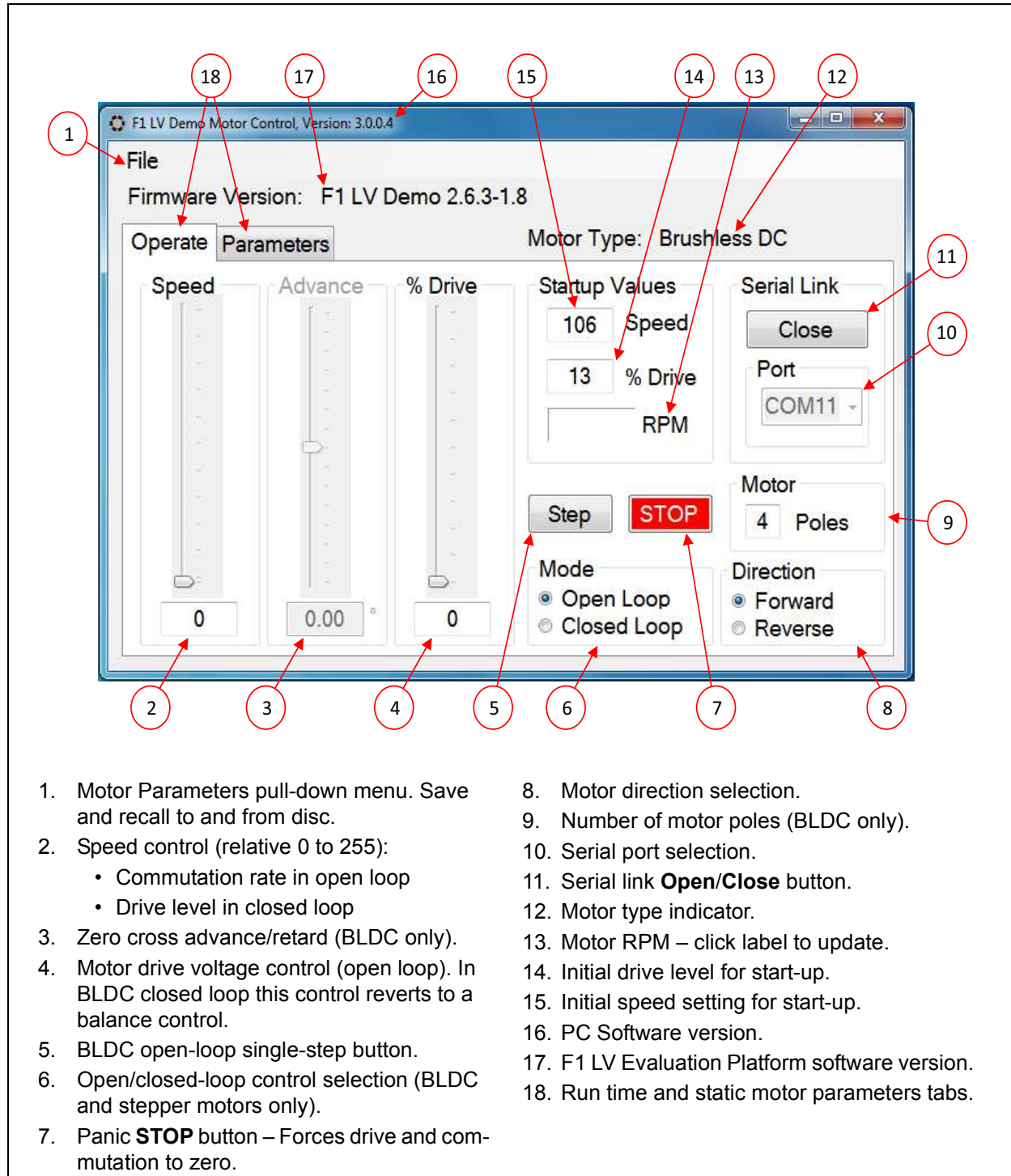

# F1 LV Evaluation Platform Motor Control Add-ons

FIGURE 1-2:

The screenshot shows the 'Parameters' tab of the 'F1 LV Demo Motor Control' software. The window title is 'F1 LV Demo Motor Control, Version: 3.0.0.4'. The firmware version is 'F1 LV Demo 2.6.3-1.8'. The motor type is set to 'Brushless DC'. The interface is divided into several sections: 'Operate' (with sub-sections for Blanking, Dwell Times, and Open Loop), 'Run/Stop (Percent)', 'Stall (us)', 'Error Scale', 'Stepper Motors' (with sub-sections for Min Duty, Max Duty, Deg Per Step, Max RPM, Micro Steps, and Step Mode), and 'uStep Table'. Red circles with numbers 19 through 33 are placed around the interface, with arrows pointing to specific controls: 19 points to the Blanking (us) input; 20 points to the Slow Step dwell time; 21 points to the Open Loop time; 22 points to the Stall (us) input; 23 points to the Error Scale input; 24 points to the Micro Steps input; 25 points to the 'New' button in the uStep Table; 26 points to the uStep Table percentage input; 27 points to the Step Mode selection; 28 points to the Max RPM input; 29 points to the Deg Per Step input; 30 points to the Min Duty input; 31 points to the Max Duty input; 32 points to the Run/Stop (Percent) input; and 33 points to the Run/Stop (Percent) input.

- 19. BLDC flyback voltage blanking time.
- 20. BLDC dwell time at each start-up step.
- 21. BLDC milliseconds to remain in Open-Loop mode at start-up before closing the loop.
- 22. BLDC minimum commutation time below which a stall is detected.
- 23. BLDC error feedback multiplication factor. Each shift divides error by 2.
- 24. Stepper motor steps in each drive phase when microstepping is selected.
- 25. Button to invoke new microstep sinusoid drive look-up table.
- 26. Peak drive level in microstep look-up table.
- 27. Stepper motor commutation mode selection.

- 28. Stepper motor maximum RPM commutation rate when speed control is set at maximum.
- 29. Degrees per step physical attribute of the attached motor.
- 30. Maximum drive voltage duty cycle applied when speed control is at the maximum RPM. This prevents excessive overdrive of the motor.
- 31. Stepper motor drive voltage duty cycle applied when speed control is at the lowest run speed above stop.
- 32. Percent of speed control setting, relative to maximum, below which the motor drive is removed and the motor is stopped.
- 33. Percent of speed control setting, relative to maximum, above which the motor starts from a stopped state.

## 1.4 USING THE F1LVDEMO CONTROL SOFTWARE

### 1.4.1 Software Updates

The software supplied and preloaded into the F1 LV Evaluation Platform supports all four of the add-on motor control boards. The preloaded software is the latest version available at time of manufacture. Source code including any updates is available for free download from the Microchip web site: [www.microchip.com/F1Eval](http://www.microchip.com/F1Eval).

All motors can be controlled with the PC-based F1LVDemo control GUI. The F1LVDemo control software is available for free download from the Microchip web site: [www.microchip.com/F1Eval](http://www.microchip.com/F1Eval).

### 1.4.2 Serial Link

The F1LVDemo control GUI operates through a USB to serial interface that appears as a standard RS-232 serial port to the PC operating system. The USB interface on the F1 LV Evaluation Platform is an MCP2200 USB to Serial interface device. Ensure that the drivers for this interface are loaded in the PC before making the connection. Interface drivers can be downloaded for free from the MCP2200 product page of the Microchip web site.

### 1.4.3 Connecting the F1 LV Evaluation Platform to the Add-on Board

Perform the following steps in the order shown to establish the link between the F1LVDemo control software and the F1 LV Evaluation Platform.

1. Connect the desired add-on board to the F1 LV Evaluation Platform J3.
2. Connect the supplied motor to the add-on board.
3. Ensure the following jumpers are in place on the F1 LV Evaluation Platform:
  - J10 – Pot Enable
  - J9 – Temperature Sense Enable
  - J4 – I Sense break
  - J6 – Expansion Board Power
4. Turn the RF2 potentiometer fully counter clockwise.
5. Each add-on board is equipped with a linear 3.3 Volt regulator that supplies power to the F1 LV Evaluation Platform.

Apply 9-12 VDC power to the add-on board. Power can be applied through the black 2.5 mm power jack or directly to the appropriate pins of the add-on board motor connector. The power jack connector is designed to accept 9 VDC, 0.75 amp wall transformer. The center pin is the positive terminal. When power is applied the F1 LV Evaluation Platform LCD will display the motor type and add-on board revision.

At this point the motor can be operated stand-alone with the potentiometer on the F1 LV Evaluation Platform. Additional motor controls are accessible only with the control GUI.

### 1.4.4 Connecting the F1 LV Evaluation Platform to the PC

6. Connect a USB cable from the PC to the F1 LV Evaluation Platform J2.
7. Execute the F1LVDemo program.
8. Select the communication port associated with the F1 LV Evaluation Platform. This will most likely be the highest numbered communication port in the selection box.
9. The communication port list is built during the F1LVDemo program initialization. If you connect to the board after the program is started, the communication port will not appear in the selection list.

# F1 LV Evaluation Platform Motor Control Add-ons

---

10. Click the **Open** button. After the link to the F1 LV Evaluation Platform is established, the F1 LV Evaluation Platform software version will be displayed, as well as the detected motor type.

When the link is established, all user accessible motor parameters stored in the add-on board will be retrieved and shown in the corresponding controls of the GUI. Controls not applicable to the detected motor will be disabled and grayed out.

## 1.4.5 Open Versus Closed Loop

The open-loop and closed-loop selections apply only to brushless DC and stepper motors. In open-loop operation, the motor voltage and speed controls are independent. In closed-loop operation the speed control functions as the control for both the speed and voltage.

Brushless DC is truly a closed-loop operation where the applied voltage is set with the speed control and the motor speed responds automatically to keep the back EMF voltage equal to the applied voltage.

Stepper motor closed-loop operation is technically not closed loop. Both the motor voltage and speed outputs simultaneously follow the single-speed control input as independent open-loop functions of the minimum and maximum speed and drive parameters.

## 1.4.6 Changing Motor Parameters

To change a motor parameter, type the new value into the corresponding text box. The initial key press clears the previous value and changes the value to red. Red indicates that the value has not been sent to the Platform RAM. When the enter key is pressed the value is immediately sent to the Evaluation Platform RAM and the display returns to the default black. The entry can be terminated without updating the Platform RAM by pressing the Escape key. Changed parameters reside in volatile RAM only. Any Platform Reset will restore the RAM values to those in the Platform EEPROM memory. Unexpected Platform Resets will cause inconsistencies between the parameters displayed in the GUI and those in the Platform RAM. Select the pull-down menu File->RAM->Display option to resynchronize the displayed values with those in the Platform RAM.

## 1.4.7 Saving and Restoring Motor Parameters

Sometimes it is useful to try many different motor setups when optimizing performance. Setups can be saved to disc storage with the pull-down menu File->Save... option.

Previously stored setups can be recovered with the pull-down menu File->Open... option. Parameters retrieved from disc update both the display and the Platform RAM.

When the optimum setup is determined those parameters can be saved to the Platform nonvolatile memory with the pull-down menu File->RAM->EEPROM option.

Parameters saved to EEPROM will be restored to RAM on every Platform Reset. The values in the Platform EEPROM can be restored to RAM without a Reset with the pull-down menu File->EEPROM->RAM option.

The EEPROM can also be restored to the factory defaults with the pull-down menu File->Defaults->EEPROM option. The factory defaults can be altered only by changing the source code and programming the Platform program memory after recompiling the source code.

## 1.4.7.1 CATASTROPHIC RECOVERY

In the unlikely event the UNI/O memory becomes erased or damaged, the memory can be completely restored with the *File->Restore->(add-on type)* option. This option should only be used if the add-on board fails the automatic detection process. Take care to select the add-on type corresponding to the attached board. Failure to do so will cause unexpected operation possibly resulting in permanent damage to the add-on board hardware.

## 1.4.8 Hints for Optimum Performance

The BLDC and stepper motors are interrupt driven. The motor commutation interrupts take precedence over all other operations. All services other than the motor commutation are polled. When the motor is operating at very rapid commutation rates, the time for other services can become severely limited. For most situations, the serial link service is able to keep up with the activity from the PC. However, when a rapid series of commands is coupled with rapid commutations, the serial link can appear to stall. To avoid this situation, use the slider controls for only small and slow changes. Enter numbers directly into the slider text box when a large change to the slider control is desired. If a stalled control condition occurs, try to regain control by clicking on the red **STOP** button. If that does not restore control, the last resort is to press the F1 LV Evaluation Platform **MCLR** button.

## 1.4.9 Header File Versus GUI Motor Parameters

The default motor parameters are defined in the F1 LV Evaluation Platform source code motor header files. The following table correlates the GUI parameters with the equivalent header file parameters. The conversion factor is the value by which the header file parameter is multiplied to derive the GUI parameter. In all cases, whether in the table or text, parameters expressed as all caps may be found exactly as shown in the header files.

See **Appendix B. "Conversion Factors"** for more information on the parameters and the associated conversion factors.

# F1 LV Evaluation Platform Motor Control Add-ons

---

**TABLE 1-2:**

Motor Type	GUI Parameter	Header File Parameter	Conversion Factor
BLDC (EBM)	Start-up: Percent Drive	MED_START_DRIVE_PCT	1
	Start-up: Speed (RPM)	START_RPM	1
	Poles	NUM_POLES	1
	Blanking	BLANKING_COUNT_us	1
	Slow Step	TIMEBASE_SLOW_STEP	10
	Open Loop	OPEN_LOOP_ms	1
	Stall	STALL_COUNT_us	1
	Run Percent	LOW_RESTORE_REQUEST_PCT	1
	Stop Percent	LOW_OFF_REQUEST_PCT	1
	Error Scale	ERROR_SCALE	1
BDC (PAN14)	Run Percent	LOW_RESTORE_REQUEST_PCT	1
	Stop Percent	LOW_OFF_REQUEST_PCT	1
Unipolar (42HS03) and Bipolar (39HS) STEPPER	Run Percent	REQUEST_ON	0.392
	Stop Percent	REQUEST_OFF	0.392
	Min. Duty Percent	MIN_DUTY	0.392
	Max. Duty Percent	MAX_DUTY	0.392
	Degrees per Step	MOTOR_STEP_ANGLE	0.1
	Max RPM	MAX_RPM	1
	uStep Table	Bipolar_CCP_Val[] Unipolar_CCP_Val[]	Varies

---

---

**Chapter 2. The BLDC Add-on Board**

---

---

**2.1 OVERVIEW**

The BLDC add-on (DM164130-2) allows you to drive virtually most sensorless three-phase brushless DC motors used in consumer electronics, ranging from small HVAC applications to complex media reading/writing drives. The add-on is shipped together with the ebm-papst BLDC motor, to which it connects through a ribbon cable to a special connector on the board (J5). Alternatively, any other 5-12V BLDC motor can be used by hooking it up through the J2 connector.

**2.1.1 Features**

The key features of this board include the following:

**Connectors:**

- Male 20-pin connector (J1) to match the F1 LV Evaluation Platform
- Generic 6-pin BLDC motor connector (J2)
- 6-pin ebm-papst motor interface (J5)
- 5-12V power supply input connector (J4)

**Typical BLDC drive:**

- Three P-type and 3 N-type MOSFETs forming three half bridges for the three motor phases
- Six bipolar transistors to command the MOSFETs
- Sensing resistor for current measurement (R15)

**Control:**

- R21 for adjusting the zero crossing voltage
- R19 for adjusting the over-current Fault detect (software for this function is not implemented).

<b>Note:</b> The function labels on these two controls are reversed on the R2 revision of these boards.
---

**Protection:**

- Power fuses (F1, F2)

**Power supply:**

- 3.3V voltage regulator (U1)

**2.1.2 What's Included**

The BLDC add-on part number (DM164130-2) contains:

- BLDC Add-on Board designed for the F1 Evaluation Platform
- ebm-papst motor (P/N: VD-3-25.07)
- 28 AWG ribbon cable to match the ebm-papst motor



# F1 LV Evaluation Platform Motor Control Add-ons

---

## 2.1.3 Reference Documents

This section points you to technical application support.

AN857, "Brushless DC Motor Control Made Easy"

AN885, "Brushless DC (BLDC) Motor Fundamentals"

AN899, "Brushless DC Motor Control Using PIC18FXX31 MCUs"

AN970, "Using the PIC18F2431 for Sensorless BLDC Motor Control"

AN1305, "Sensorless 3-Phase Brushless Motor Control with the PIC16FXXX"

You can obtain these reference documents from your nearest Microchip sales office (listed in the last page of this document) or by downloading them from the Microchip web site.

## 2.2 BOARD SETUP

### WARNING

The BLDC Motor Control Add-on Board is intended to drive three-phase brushless DC motors. Before connecting the motor, make sure the power rating of the motor is equal to or less than the power rating of the board, as shown in Appendix B. "Conversion Factors". Also, make sure the configuration parameters inside the software or the GUI are correct for the motor you are using. Failure to comply with this warning could lead to malfunction of the board and the motor, and could result in physical harm. Before beginning the start-up procedure, complete a visual check of the board and the motor for connectivity and mechanical damage. If damage is found, DO NOT power-up the board. Otherwise, you may further damage the equipment. Contact Microchip's local office or distributor immediately.

A step-by-step connecting procedure is available in **Section 1.4.3 "Connecting the F1 LV Evaluation Platform to the Add-on Board"**. If using the ebm-papst motor, attach the ribbon cable from the motor at step 2. Also, make sure that POR R4 on the evaluation platform is turned fully CCW.

If using a different motor, connected through J2, please keep in mind to attach each motor phase firmly to the connector. The red connector supplied with the board is designed to accept 22 AWG wire. Bad contacts can damage the add-on and will wear out the motor in time. There is no rule for attaching a specific motor lead to a phase line on the add-on. Keep in mind the correspondences on the software side when testing or measuring directly on that motor phase.

Adjust R21 90 degrees CCW from the mid-point CCW when operating the ebm-papst motor. R21 should be set to its mid-point for other motors.

## 2.3 HARDWARE

### 2.3.1 General Architecture

The BLDC add-on uses a typical three half-bridges control configuration suitable for three-phase BLDC motors, using six MOSFETS commanded through six bipolar transistors. Sensorless control is done in the software without any other external components.

[Figure 2-1](#) provides a simplified block diagram of the development board hardware, coupled to the F1 LV Evaluation Platform:

**FIGURE 2-1: THE BLDC MOTOR CONTROL ADD-ON ARCHITECTURE**

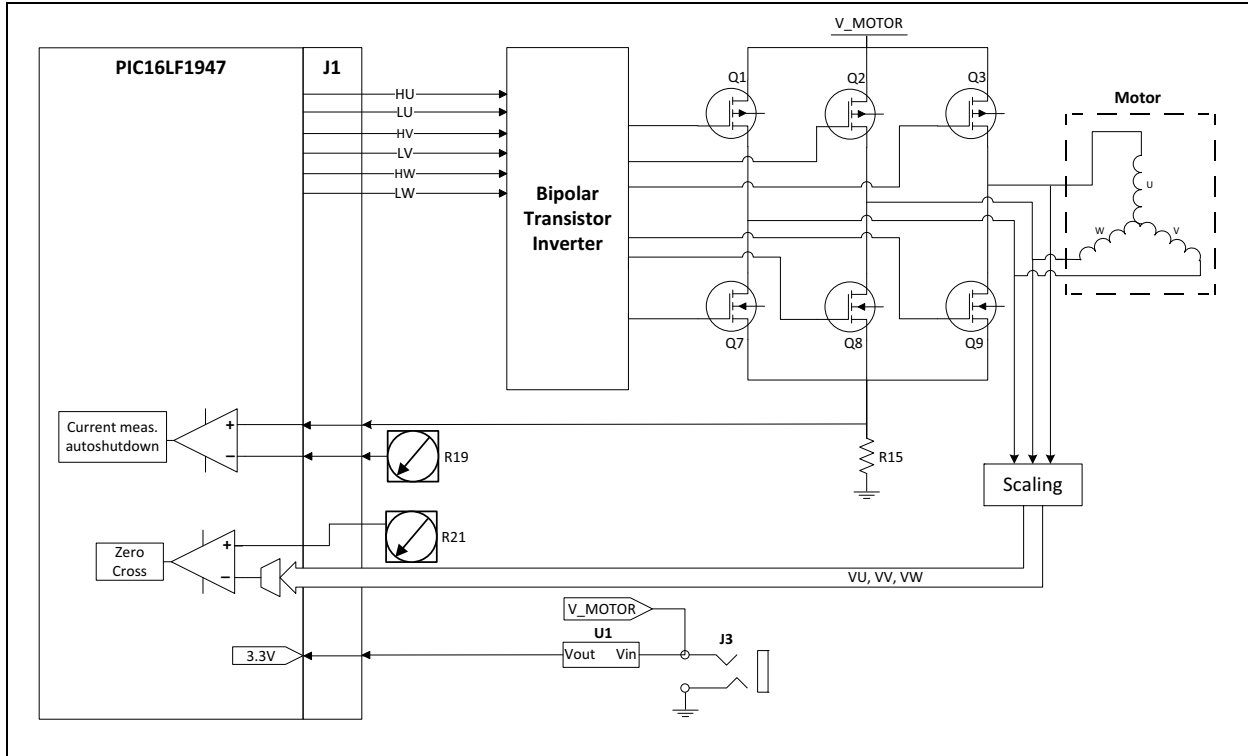

### 2.3.2 Attaching the Motor

The BLDC add-on kit includes the three-phase 24V ebm-papst motor. This motor can be attached through a dedicated 28AWG 8-wire ribbon cable using connector J5.

**FIGURE 2-2: THE EBM-PAPST MOTOR CONNECTOR**

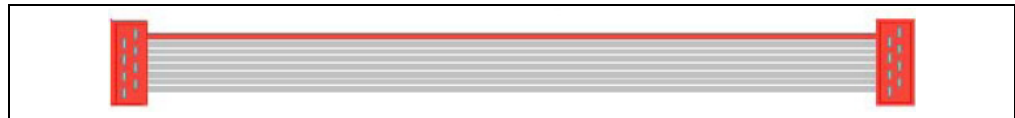

However, you can use your own three-phase BLDC motor by attaching its leads to the J2 connector. The red connector supplied with the board is designed to accept 22 AWG wire.

### 2.3.3 Power-Up

Voltage is supplied through the 2.5 mm jack connector J4, with a maximum rating of +12 VDC. The F1 LV Evaluation Platform should be configured to use expansion board power by inserting the power jumper on J6. See the “F1 LV Evaluation Platform for Enhanced PIC® Microcontrollers User’s Guide” (DS41614A) for more details.

### 2.3.4 Power Stage

The BLDC add-on incorporates the classic three half-bridges drive made from P and N-type MOSFETs (for more details, please refer to the BLDC board schematic in **Appendix A. “Board Layout and Schematics”**). The maximum current rating is 8A on each MOSFET. Please keep this in mind when designing your application or modifying the add-on hardware.

The stage contains six PWM (HU, LU, HV, LV, HW, LW) inputs and three back EMF sense outputs (VU, VV, VW). The BLDC motor attaches to the three driver outputs (U, V, W).

# F1 LV Evaluation Platform Motor Control Add-ons

---

Motor current is measured by using the R15 shunt resistor, placed in-between the Power Stage lowside and ground, and connected to the PIC16F1947 through the J1 connector. (Current sensing is not implemented in the F1 LV Evaluation software.)

## 2.3.5 Protection

Two 5A fuses (F1 and F2) are used to protect your add-on in case of an overcurrent situation in the output drivers. In case one or both of them get burnt, remove power immediately from the board and inspect the add-on for further damage. Do not replace the burnt fuses with other values than the ones provided with the board.

## 2.3.6 Speed Control

Speed control can be performed through either the Motor Control GUI or the 10K POT R4 located on the F1 LV Evaluation Platform.

## 2.4 DEMO SOFTWARE

### 2.4.1 Introduction

The F1 LV Evaluation demonstration program uses a single combined demo. The combined demo source code is organized into sectional code for ease of accommodating several motor types. This chapter provides an overview to the functions provided by the BLDC demo.

The BLDC demo code is designed to operate a sensorless BLDC control. The software can be easily tuned to the needs of your application or motor by changing the parameters on-the-fly, by modifying the motor parameters in the F1LVDemo GUI.

### 2.4.2 The Motor Control GUI Application

Using the Motor Control Application GUI, you can change the following parameters:

- Motor poles number
- Speed [arbitrary range 0 to 255]
- The timing balance between zero-cross and commutation periods [degrees]
- Phase advance [degrees]
- Start-up speed [arbitrary range 0 to 255]
- Drive voltage [% of full scale]
- The minimum blanking period [us]
- Dwell timings: closed-loop slow stepping [ms] and open loop [ms]
- Run/stop hysteresis drive voltage [% of full scale]
- Minimum motor stalling period [us]
- Error scaling factor [divisor power of 2].

Also, the motor can be run in open/closed loop and forward/reverse.

Clicking on the 'RPM' text in the **Operate** tab will display the motor speed in the text box next to it.

## 2.4.3 BLDC Parameter Optimization

Brushless motors depend on the software to commutate the motor. The software must determine the rotor position relative to the stator so as to commutate the driver circuitry at specific rotor positions. The rotor position is determined in sensorless motors by voltages induced into the stator by rotor motion. The induced voltage is referred to as back EMF or BEMF. When the rotor is stationary, there is no BEMF from which to determine the rotor position. Starting the motor requires commutating the motor blindly, without the benefit of feedback, to start the rotor in motion fast enough to sense the BEMF, and close the loop on rotor position for commutation.

The motor speed, in response to the applied voltage, varies by motor design. We need to match the initial drive voltage and open-loop commutation rate to the motor to accomplish two objectives:

1. prevent excessive current in the motor
2. start rotation fast enough to sense the BEMF

When the motor is running, the BEMF on the driven pair of stator windings matches the applied voltage. The BEMF on the undriven winding starts at one power rail at the beginning of the commutation period and ends at the other power rail at the end of the commutation period. However, this is only true when the motor is running at the design speed. At any other speed, the BEMF is effectively undetectable. Unfortunately, the motor will not start if we apply a voltage, and then commutate at the rate for which the motor is designed. To start the motor, we need to commutate slower than the design rate and then ramp up to the design speed.

The task of motor optimization is to find a combination of applied voltage and commutation rate for which the motor will start to rotate. From there, the control algorithm will ramp-up the commutation rate to where the BEMF can be sensed. The Motor Control GUI enables us to independently set the applied motor voltage and commutation rate to find a combination that works. Use the following steps to experiment with your motor optimization:

1. Set POT R21 to middle range for your motor or 90 degrees CCW from the middle range for the ebm-papst motor supplied with the BLDC Add-on Board.
2. Select Open-Loop mode.
3. Set the speed control to a nominal rate, such as 100.
4. Slowly increase the % Drive control until the motor starts to turn.
5. Slowly increase the speed control until it is just faster than the motor can go.
6. Slowly reduce the speed control until the motor starts to rotate again.
7. Note the % Drive setting, then enter 0 into the % drive control text box.
8. Re-enter the % drive setting noted in step 6, and observe that the motor starts spinning.
9. Repeat steps 7 and 8 to verify the motor always starts reliably. If it does not, then reduce the speed control slightly and repeat steps 6, 7 and 8.
10. When you are satisfied with the start response obtained by steps 6, 7 and 8, then enter the final speed control value into the Speed Start-up value text box. The equivalent RPM will be displayed.

**Note:** The displayed RPM value is only accurate if the motor has the number of poles indicated. The number of poles only matters if you want the RPM value to represent the mechanical operation. If you are not sure how many poles your motor has, then you can determine this by leaving the % Drive where it is, setting the speed to zero, and count the number of **Step** button clicks it takes to make one full motor revolution. Divide this number by three, that is the number of poles.