



Chipsmall Limited consists of a professional team with an average of over 10 year of expertise in the distribution of electronic components. Based in Hongkong, we have already established firm and mutual-benefit business relationships with customers from,Europe,America and south Asia,supplying obsolete and hard-to-find components to meet their specific needs.

With the principle of “Quality Parts,Customers Priority,Honest Operation,and Considerate Service”,our business mainly focus on the distribution of electronic components. Line cards we deal with include Microchip,ALPS,ROHM,Xilinx,Pulse,ON,Everlight and Freescale. Main products comprise IC,Modules,Potentiometer,IC Socket,Relay,Connector.Our parts cover such applications as commercial,industrial, and automotives areas.

We are looking forward to setting up business relationship with you and hope to provide you with the best service and solution. Let us make a better world for our industry!



Contact us

Tel: +86-755-8981 8866 Fax: +86-755-8427 6832

Email & Skype: info@chipsmall.com Web: www.chipsmall.com

Address: A1208, Overseas Decoration Building, #122 Zhenhua RD., Futian, Shenzhen, China



miniSD™ Card Connectors

DM2 Series

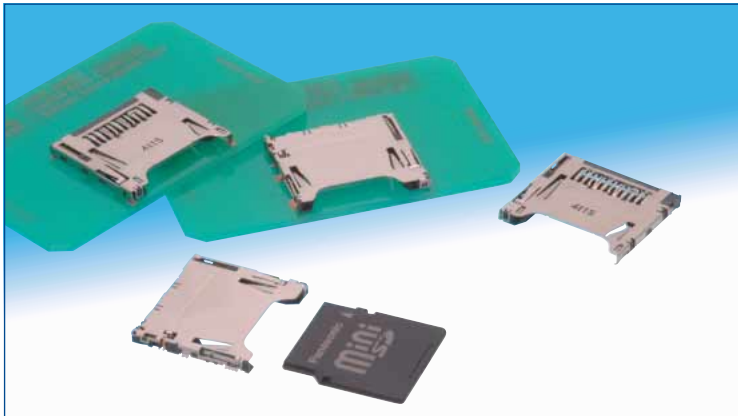

Extremely small size (Standard – top board mounting) DM2A

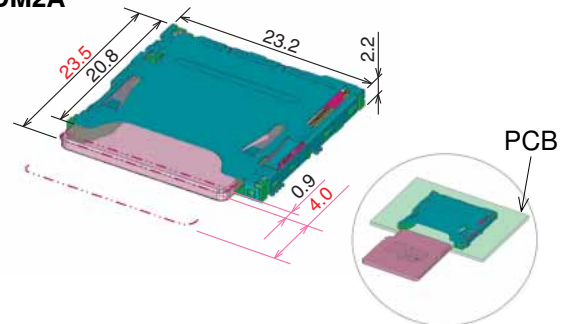

■ Features

1. Extremely small size

Board footprint as well as the length, width and height of the connector has been reduced in order to minimize use of valuable space in today's miniature devices. With the miniSD™ card inserted the overall length is shortest in the industry.

2. Push-in / Push-out card ejection

Inserted card is securely held in place with an approximate force of 4 N, assuring reliable connection and retention in the connector, even when subjected to accidental shock. When pushed again, the card will self-eject to distance of 4 mm, allowing safe removal from the connector.

3. Protection against card loss

Built-in card retention springs will keep the card inserted when card may be accidentally partially pulled-out.

4. Protection against reverse card insertion

The ejection mechanism is designed not to lock when the card is inserted in reverse, alerting the user to insert it correctly. Reverse card insertion will not damage the contacts.

5. Effective grounding and shielding

The VSS contacts connect directly to the metal cover, assuring superior ground connection (Patents pending.) In addition, metal cover will connect with the PC board surface at four points, providing highly effective grounding and shielding of the connector.

6. Durable, load-resistant construction

While miniature in size and lightweight, the use of metal cover assures it's reliable and stable performance.

7. Two-point contact

Two-point contact offers high contact reliability.

8. Built-in card detection switch

The card detection switch is a normally closed, opening when the card is inserted.

9. RoHS Compliant

All components and materials comply with the requirements of EU Directive 2002/95/EC.

■ Applications

Mobile phones, digital cameras, PDA's and any other portable device requiring use of miniSD™ memory card.

*miniSD™ is a trademark of the SD Card Association.

Extremely small size (Reverse – bottom board mounting) DM2B

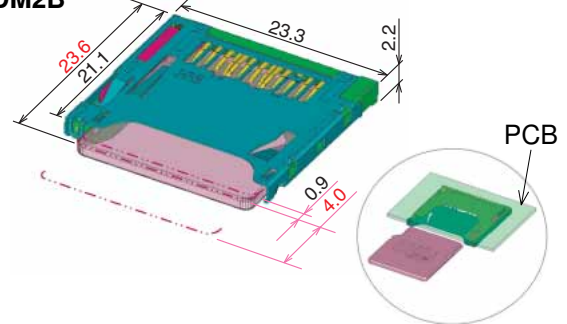

Card ejection prevention mechanism

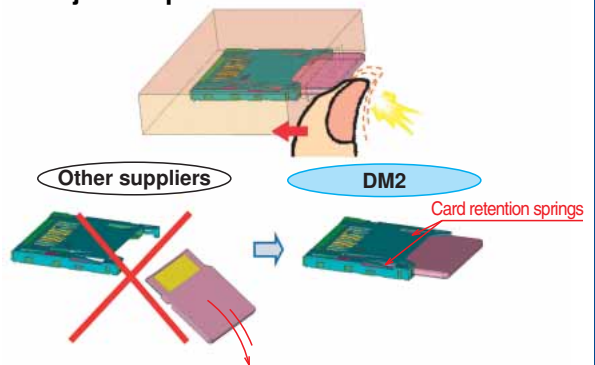

Two-point contact

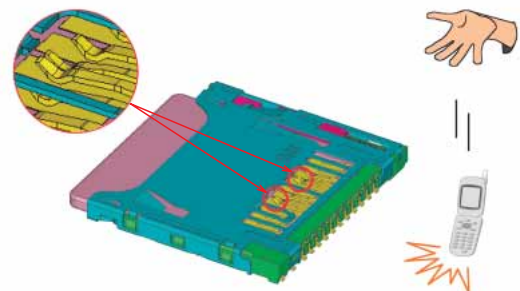

DM2 Series miniSD Card Connectors

Product Specifications

Ratings	Current rating: 0.5A DC	Operating temperature range: -25°C to +85°C (Note 1)	Operating humidity range: Relative humidity 95% max. (No condensation)
	Voltage rating: 125V AC	Storage temperature range: -40°C to +85°C (Note 2)	

Item	Specification	Conditions
1. Insulation resistance	1000 MΩ min. (Initial value)	500V DC
2. Withstanding voltage	No flashover or insulation breakdown.	500V AC / one minute
3. Contact resistance	100mΩ max. (Initial value)	100mA DC
4. Vibration	No electrical discontinuity of 100 ns or more.	Frequency: 10 to 55 Hz, single amplitude of 0.75mm, 2 hours / 3 axis
5. Humidity	Contact resistance : 40mΩ max. from initial value Insulation resistance : 100MΩ min.	96 hours at 40°C±2°C and humidity of 90% to 95%.
6. Temperature cycle	Contact resistance : 40mΩ max. from initial value Insulation resistance : 100MΩ min.	Temperature: -55°C→+5°C to +35°C→+85°C→+5°C to +35°C Duration: 30→5→30→5 (Minutes) 5 cycles
7. Durability (mating/unmating)	Contact resistance : 40mΩ max. from initial value	10000 cycles at 400 to 600 cycles per hour
8. Resistance to soldering heat	No deformation of components affecting form, fit or function.	Reflow: At the recommended temperature profile Manual soldering: 350°C for 3 seconds

Note 1: Includes temperature rise caused by current flow.

Note 2: The term "storage" refers to products stored for long period of time prior to mounting and use. Operating temperature range and humidity range covers non-conducting condition of installed connectors in storage, shipment or during transportation.

Materials / Finish

Component	Material	Finish	Remarks
Insulator	Heat resistant thermoplastic compound	Color: Black	UL94V-0
Contacts	Phosphor bronze	Contact area : Gold plated Termination area : Gold plated	_____
Cover	Copper alloy	_____	_____
Other components	Stainless steel	_____	_____
	Steel wire	Nickel plated	

Ordering information

DM2 * - * - PEJ - *

① ② ③ ④ ⑤

① Series name :DM2	④ Card ejection code PEJ: Push insert/push eject	
② Connector type A:Standard receptacle B:Reverse receptacle Number of contacts :11		⑤ Ground terminal type S: SMT - at 4 points D1S: Through hole at 2 points + SMT at 4 points
③ Termination type SFW: Right angle SMT (Standard mounting) DSFW: Right angle SMT (Reverse mounting)		

Standard (Top board mounting)

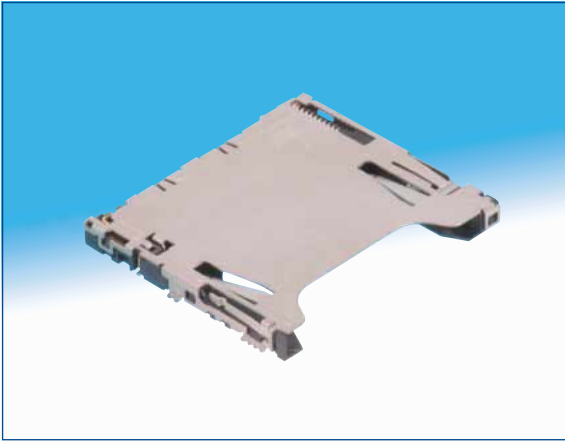

Part number	CL No.	Packaging	RoHS
DM2A-SFW-PEJ-S	609-0010-0	800 pcs. per reel	YES

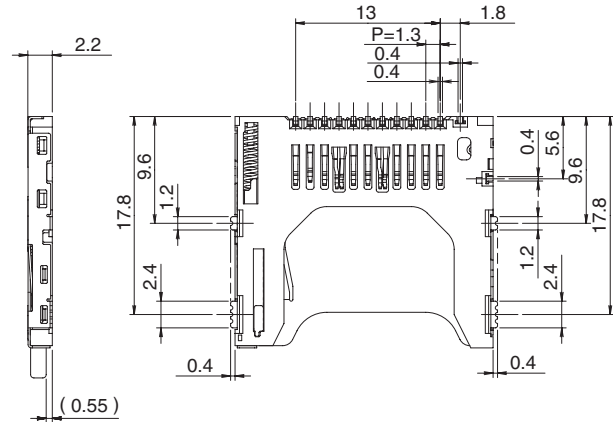
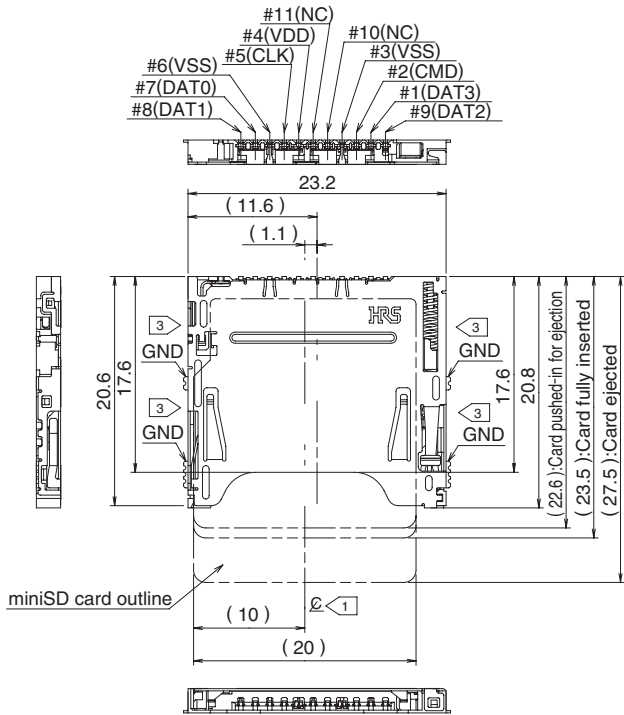

PCB mounting pattern

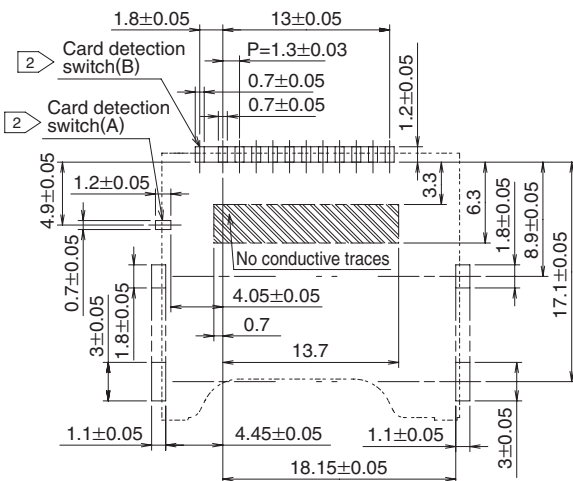

1 \varnothing Indicates the center line of card slot.

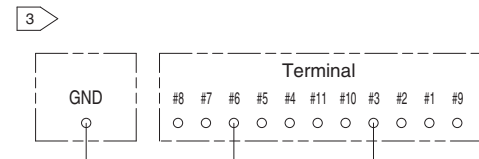
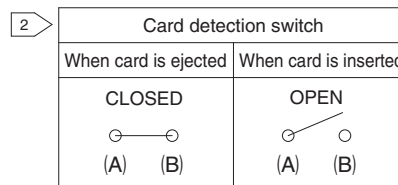

DMZ Series miniSD™ Card Connectors

■ Packaging Specifications

- Embossed carrier tape dimensions (800 pieces per reel)

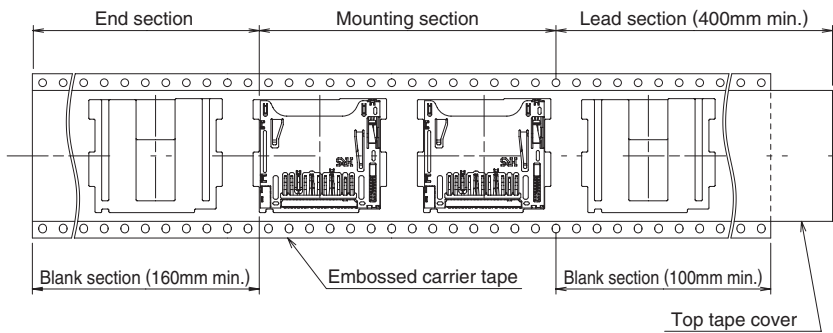

- Reel dimensions

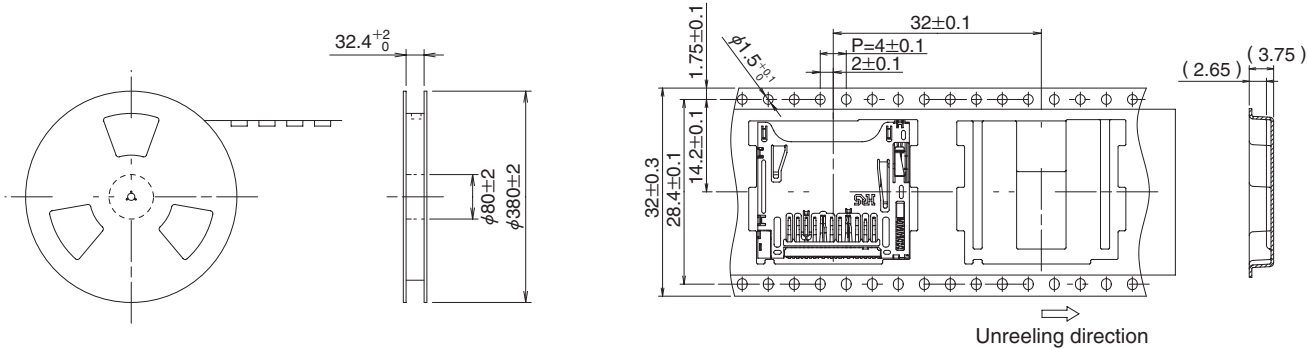

■ Recommended temperature profile

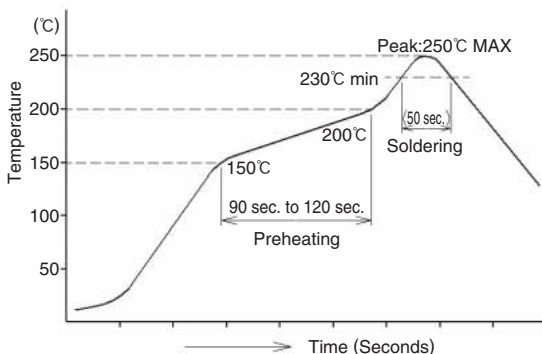

<Recommended conditions>

- Reflow system : IR/Hot air
- Environment : Room air
- Solder composition : Paste, 96.5%Sn / 3.0%Ag / 0.5%Cu (M705-221CM5-42-10.5 manufactured by Senju Metal Industry Co., Ltd.)
- Test board : Glass epoxy 60mm x 100mm x 1mm thick
- Metal mask thickness : 0.12 mm

This temperature profile is based on the above conditions. In individual applications the actual temperature may vary, depending on solder paste type, volume/thickness and board size/thickness. Consult your solder paste and equipment manufacturer for specific recommendations.

■ Precautions and recommendations

1. Washing recommendations

Do not wash the entire connector. Intrusion of washing fluids in the connector may affect the operation of the ejection mechanism, card insertion or electrical performance.

If required, wash only soldered joints, exercising caution not to allow intrusion of washing solution inside the connector.

2. Use correct card

The connector is designed for miniSD™ card.

Although it will withstand reverse card insertion attempts without damage, care should be taken NOT to subject it to extreme insertion forces, angle insertion or card twisting.

3. Do not apply excessive external force

Application of excessive external force during card insertion or removal may cause malfunction or damage to the connector or card.