



Chipsmall Limited consists of a professional team with an average of over 10 year of expertise in the distribution of electronic components. Based in Hongkong, we have already established firm and mutual-benefit business relationships with customers from,Europe,America and south Asia,supplying obsolete and hard-to-find components to meet their specific needs.

With the principle of “Quality Parts,Customers Priority,Honest Operation,and Considerate Service”,our business mainly focus on the distribution of electronic components. Line cards we deal with include Microchip,ALPS,ROHM,Xilinx,Pulse,ON,Everlight and Freescale. Main products comprise IC,Modules,Potentiometer,IC Socket,Relay,Connector.Our parts cover such applications as commercial,industrial, and automotives areas.

We are looking forward to setting up business relationship with you and hope to provide you with the best service and solution. Let us make a better world for our industry!



Contact us

Tel: +86-755-8981 8866 Fax: +86-755-8427 6832

Email & Skype: info@chipsmall.com Web: www.chipsmall.com

Address: A1208, Overseas Decoration Building, #122 Zhenhua RD., Futian, Shenzhen, China



DM74ALS109A

Dual J-K Positive-Edge-Triggered Flip-Flop with Preset and Clear

General Description

The DM74ALS109A is a dual edge-triggered flip-flop. Each flip-flop has individual J, \bar{K} , clock, clear and preset inputs, and also complementary Q and \bar{Q} outputs.

Information at input J or \bar{K} is transferred to the Q output on the positive going edge of the clock pulse. Clock triggering occurs at a voltage level of the clock pulse and is not directly related to the transition time of the positive going pulse. When the clock input is at either the HIGH or LOW level, the J, K input signal has no effect.

Asynchronous preset and clear inputs will set or clear Q output respectively upon the application of low level signal.

The J- \bar{K} design allows operation as a D flip-flop by tying the J and \bar{K} inputs together.

Features

- Switching specifications at 50 pF
- Switching specifications guaranteed over full temperature and V_{CC} range
- Advanced oxide-isolated, ion-implanted Schottky TTL process
- Functionally and pin for pin compatible with Schottky and LS TTL counterpart
- Improved AC performance over LS109 at approximately half the power

Ordering Code:

Order Number	Package Number	Package Description
DM74ALS109AM	M16A	16-Lead Small Outline Integrated Circuit (SOIC), JEDEC MS-012, 0.150 Narrow
DM74ALS109AN	N16E	16-Lead Plastic Dual-In-Line Package (PDIP), JEDEC MS-001, 0.300 Wide

Devices also available in Tape and Reel. Specify by appending the suffix letter "X" to the ordering code.

Connection Diagram

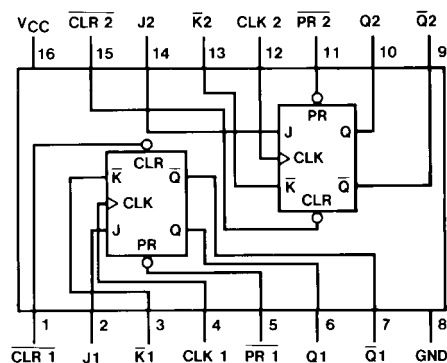

Function Table

Inputs					Outputs	
\overline{PR}	\overline{CLR}	CK	J	\bar{K}	Q	\bar{Q}
L	H	X	X	X	H	L
H	L	X	X	X	L	H
L	L	X	X	X	H (Note 1)	H (Note 1)
H	H	↑	L	L	L	H
H	H	↑	H	L	TOGGLE	
H	H	↑	L	H	Q_0	\bar{Q}_0
H	H	↑	H	H	H	L
H	H	L	X	X	Q_0	\bar{Q}_0

L = LOW State
H = HIGH State
X = Don't Care
↑ = Positive Edge Transition,
 Q_0 = Previous Condition of Q

Note 1: This condition is nonstable; it will not persist when present and clear inputs return to their inactive (HIGH) level. The output levels in this condition are not guaranteed to meet the V_{OH} specification.

Logic Diagram

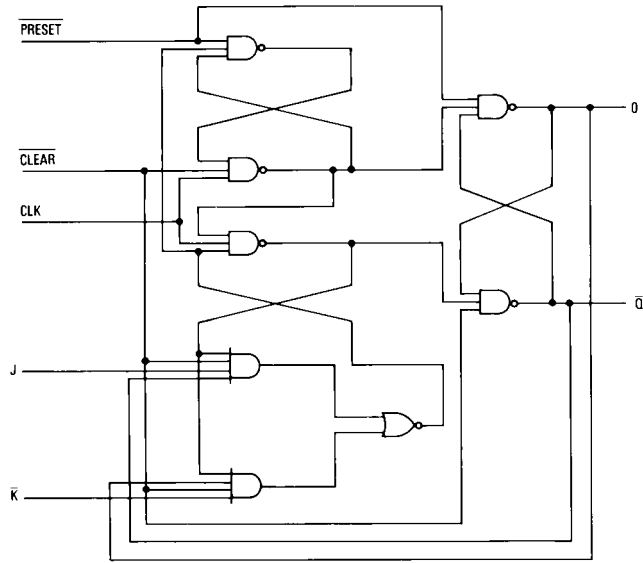

Absolute Maximum Ratings(Note 2)

Supply Voltage	7V
Input Voltage	7V
Operating Free Air Temperature Range	0°C to +70°C
Storage Temperature Range	-65°C to +150°C
Typical θ_{JA}	
N Package	82.5°C/W
M Package	111.5°C/W

Note 2: The "Absolute Maximum Ratings" are those values beyond which the safety of the device cannot be guaranteed. The device should not be operated at these limits. The parametric values defined in the Electrical Characteristics tables are not guaranteed at the absolute maximum ratings. The "Recommended Operating Conditions" table will define the conditions for actual device operation.

Recommended Operating Conditions

Symbol	Parameter	Min	Nom	Max	Units
V_{CC}	Supply Voltage	4.5	5	5.5	V
V_{IH}	HIGH Level Input Voltage	2			V
V_{IL}	LOW Level Input Voltage			0.8	V
I_{OH}	HIGH Level Output Current			-0.4	mA
I_{OL}	LOW Level Output Current			8	mA
f_{CLK}	Clock Frequency	0		34	MHz
$t_{W(CLK)}$	Pulse Width	Clock HIGH	14.5		ns
		Clock LOW	14.5		ns
t_W	Pulse Width (Note 3)	Pres̄et and \overline{C} lear	15		ns
t_{SU}	Data Setup Time (Note 3)	J or \overline{K}	15 \uparrow		ns
		\overline{PRE} or \overline{CLR} inactive	10 \uparrow		
t_H	Data Hold Time		0 \uparrow		ns
T_A	Free Air Operating Temperature	0		70	°C

Note 3: The (\uparrow) arrow indicates the positive edge of the Clock is used for reference.

Electrical Characteristics

over recommended operating free-air temperature range. All typical values are measured at $V_{CC} = 5V$, $T_A = 25^\circ C$.

Symbol	Parameter	Conditions	Min	Typ	Max	Units
V_{IK}	Input Clamp Voltage	$V_{CC} = 4.5V$, $I_I = -18\text{ mA}$			-1.5	V
V_{OH}	HIGH Level Output Voltage	$I_{OH} = -400\ \mu A$ $V_{CC} = 4.5V\text{ to }5.5V$	$V_{CC} - 2$			V
V_{OL}	LOW Level Output Voltage	$V_{CC} = 4.5V$ $V_{IH} = 2V$	$I_{OL} = 4\text{ mA}$	0.25	0.4	V
			$I_{OL} = 8\text{ mA}$	0.35	0.5	V
I_I	Input Current at Max Input Voltage	$V_{CC} = 5.5V$, $V_{IH} = 7V$	Clock, J, \overline{K}		0.1	mA
			$\overline{\text{Preset}}$, $\overline{\text{Clear}}$		0.2	
I_{IH}	High Level Input Current	$V_{CC} = 5.5V$, $V_{IH} = 2.7V$	Clock, J, \overline{K}		20	μA
			$\overline{\text{Preset}}$, $\overline{\text{Clear}}$		40	
I_{IL}	Low Level Input Current	$V_{CC} = 5.5V$, $V_{IL} = 0.4V$	Clock, J, \overline{K}		-0.2	mA
			$\overline{\text{Preset}}$, $\overline{\text{Clear}}$		-0.4	
I_O (Note 4)	Output Drive Current	$V_{CC} = 5.5V$, $V_O = 2.25V$	-30		-112	mA
I_{CC}	Supply Current	$V_{CC} = 5.5V$ (Note 5)		2.4	4	mA

Note 4: The output conditions have been chosen to produce a current that closely approximates one half of the true short circuit output current, I_{OS} .

Note 5: I_{CC} is measured with J, \overline{K} , CLK and $\overline{\text{PRESET}}$ grounded, then with J, \overline{K} , CLK and $\overline{\text{CLEAR}}$ grounded.

Switching Characteristics

over recommended operating free air temperature range

Symbol	Parameter	Conditions	From	To	Min	Max	Units
f_{MAX}	Maximum Clock Frequency	$V_{CC} = 4.5V\text{ to }5.5V$			34		MHz
t_{PLH}	Propagation Delay Time LOW-to-HIGH Level Output	$R_L = 500\ \Omega$ $C_L = 50\text{ pF}$	$\overline{\text{Preset}}$ or $\overline{\text{Clear}}$	Q or \overline{Q}	3	13	ns
			$\overline{\text{Preset}}$ or $\overline{\text{Clear}}$	Q or \overline{Q}	5	15	ns
t_{PLH}	Propagation Delay Time LOW-to-HIGH Level Output		Clock	Q or \overline{Q}	5	16	ns
t_{PHL}	Propagation Delay Time HIGH-to-LOW Level Output		Clock	Q or \overline{Q}	5	18	ns

Physical Dimensions inches (millimeters) unless otherwise noted



16-Lead Small Outline Integrated Circuit (SOIC), JEDEC MS-012, 0.150 Narrow Package Number M16A

Physical Dimensions inches (millimeters) unless otherwise noted (Continued)

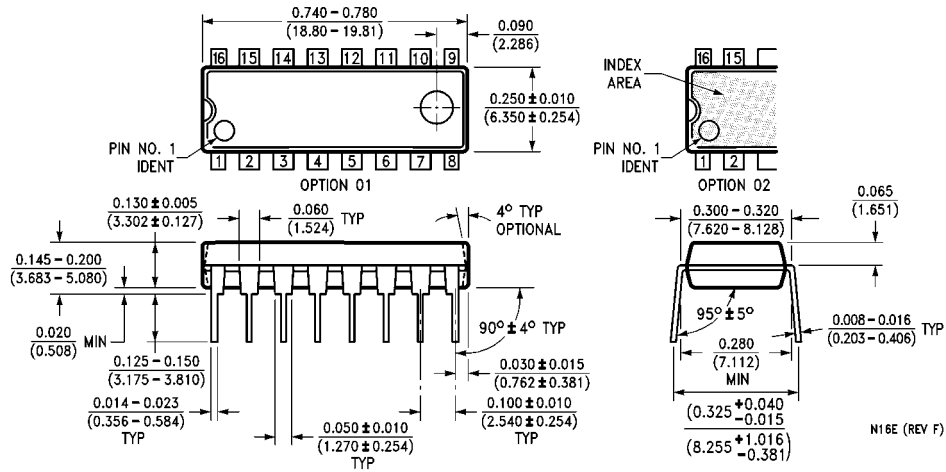

16-Lead Plastic Dual-In-Line Package (PDIP), JEDEC MS-001, 0.300 Wide Package Number N16E

Fairchild does not assume any responsibility for use of any circuitry described, no circuit patent licenses are implied and Fairchild reserves the right at any time without notice to change said circuitry and specifications.

LIFE SUPPORT POLICY

FAIRCHILD'S PRODUCTS ARE NOT AUTHORIZED FOR USE AS CRITICAL COMPONENTS IN LIFE SUPPORT DEVICES OR SYSTEMS WITHOUT THE EXPRESS WRITTEN APPROVAL OF THE PRESIDENT OF FAIRCHILD SEMICONDUCTOR CORPORATION. As used herein:

1. Life support devices or systems are devices or systems which, (a) are intended for surgical implant into the body, or (b) support or sustain life, and (c) whose failure to perform when properly used in accordance with instructions for use provided in the labeling, can be reasonably expected to result in a significant injury to the user.
2. A critical component in any component of a life support device or system whose failure to perform can be reasonably expected to cause the failure of the life support device or system, or to affect its safety or effectiveness.

www.fairchildsemi.com