

Chipsmall Limited consists of a professional team with an average of over 10 year of expertise in the distribution of electronic components. Based in Hongkong, we have already established firm and mutual-benefit business relationships with customers from,Europe,America and south Asia,supplying obsolete and hard-to-find components to meet their specific needs.

With the principle of “Quality Parts,Customers Priority,Honest Operation,and Considerate Service”,our business mainly focus on the distribution of electronic components. Line cards we deal with include Microchip,ALPS,ROHM,Xilinx,Pulse,ON,Everlight and Freescale. Main products comprise IC,Modules,Potentiometer,IC Socket,Relay,Connector.Our parts cover such applications as commercial,industrial, and automotives areas.

We are looking forward to setting up business relationship with you and hope to provide you with the best service and solution. Let us make a better world for our industry!



## Contact us

Tel: +86-755-8981 8866 Fax: +86-755-8427 6832

Email & Skype: [info@chipsmall.com](mailto:info@chipsmall.com) Web: [www.chipsmall.com](http://www.chipsmall.com)

Address: A1208, Overseas Decoration Building, #122 Zhenhua RD., Futian, Shenzhen, China

## DM74ALS273

### Octal D-Type Edge-Triggered Flip-Flop with Clear

#### General Description

These monolithic, positive-edge-triggered flip-flops utilize TTL circuitry to implement D-type flip-flop logic with a direct clear input.

Information at the D inputs meeting the setup requirements is transferred to the Q outputs on the positive-going edge of the clock pulse. Clock triggering occurs at a particular voltage level and is not directly related to the transition time of the positive-going pulse. When the clock input is at either the HIGH or LOW level, the D input signal has no effect at the output.

#### Features

- Switching specifications at 50 pF
- Switching specifications guaranteed over full temperature and  $V_{CC}$  range
- Buffer-type outputs and improved AC offer significant advantage over DM74LS273.
- Advanced oxide-isolated, ion-implanted Schottky TTL process
- Functionally and pin-for-pin compatible with DM74ALS273.

#### Ordering Code:

Order Number	Package Number	Package Description
DM74ALS273WM	M20B	20-Lead Small Outline Integrated Circuit (SOIC), JEDEC MS-013, 0.300 Wide
DM74ALS273SJ	M20D	20-Lead Small Outline Package (SOP), EIAJ TYPE II, 5.3mm Wide
DM74ALS273MSA	MSA20	20-Lead Shrink Small Outline Package (SSOP), EIAJ TYPE II, 5.3mm Wide
DM74ALS273N	N20A	20-Lead Plastic Dual-In-Line Package (PDIP), JEDEC MS-001, 0.300 Wide

Devices also available in Tape and Reel. Specify by appending the suffix letter "X" to the ordering code.

#### Connection Diagram

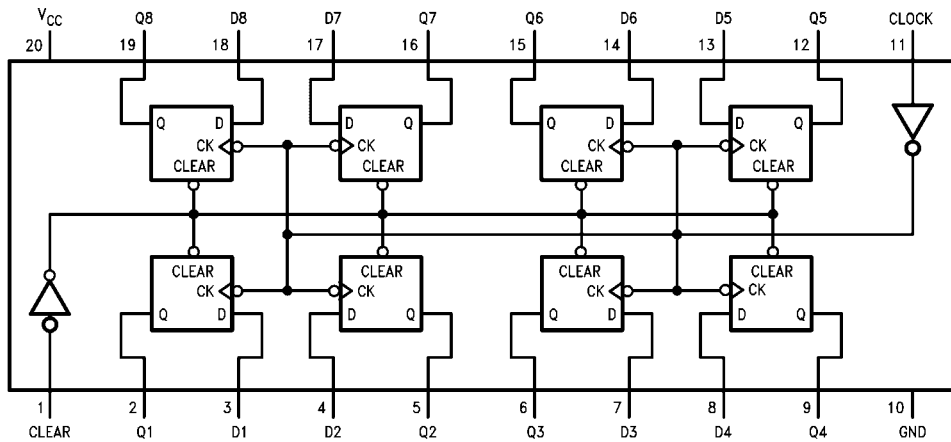

DM74ALS273 Octal D-Type Edge-Triggered Flip-Flop with Clear

### Function Table

(Each Flip-Flop)

Inputs			Output Q
Clear	Clock	D	
L	X	X	L
H	↑	H	H
H	↑	L	L
H	L	X	Q <sub>0</sub>

L = LOW State  
 H = HIGH State  
 X = Don't Care  
 ↑ = Positive Edge Transition  
 Q<sub>0</sub> = Previous Condition of Q

### Logic Diagram

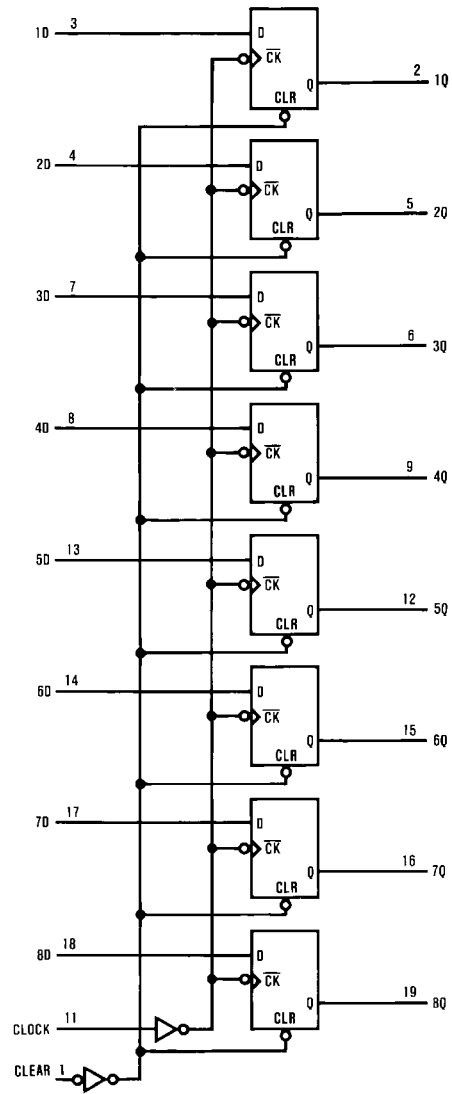

**Absolute Maximum Ratings**(Note 1)

Supply Voltage	7V
Input Voltage	7V
Operating Free Air Temperature Range	0°C to +70°C
Storage Temperature Range	-65°C to +150°C
Typical $\theta_{JA}$	
N Package	60.0°C/W
M Package	79.0°C/W

**Note 1:** The "Absolute Maximum Ratings" are those values beyond which the safety of the device cannot be guaranteed. The device should not be operated at these limits. The parametric values defined in the Electrical Characteristics tables are not guaranteed at the absolute maximum ratings. The "Recommended Operating Conditions" table will define the conditions for actual device operation.

**Recommended Operating Conditions**

Symbol	Parameter	Min	Nom	Max	Units
$V_{CC}$	Supply Voltage	4.5	5	5.5	V
$V_{IH}$	HIGH Level Input Voltage	2			V
$V_{IL}$	LOW Level Input Voltage			0.8	V
$I_{OH}$	HIGH Level Output Current			-2.6	mA
$I_{OL}$	LOW Level Output Current			24	mA
$f_{CLK}$	Clock Frequency	0		35	MHz
$t_{W(CLK)}$	Width of Clock Pulse	HIGH	14		ns
		LOW	14		ns
$t_W$	Width of Clear Pulse	LOW	10		ns
$t_{SU}$	Data Setup Time (Note 2)		10 $\uparrow$		ns
		Clear Inactive	15 $\uparrow$		
$t_H$	Data Hold Time		0 $\uparrow$		ns
$T_A$	Free Air Operating Temperature	0		70	°C

**Note 2:** The ( $\uparrow$ ) arrow indicates the positive edge of the Clock is used for reference.

**Electrical Characteristics**

over recommended operating free air temperature range. All typical values are measured at  $V_{CC} = 5V$ ,  $T_A = 25^\circ C$ .

Symbol	Parameter	Conditions	Min	Typ	Max	Units	
$V_{IK}$	Input Clamp Voltage	$V_{CC} = 4.5V$ , $I_I = -18\text{ mA}$			-1.5	V	
$V_{OH}$	HIGH Level Output Voltage	$V_{CC} = 4.5V$	$I_{OH} = -2.6\text{ mA}$	2.4	3.3	V	
		$V_{CC} = 4.5V$ to $5.5V$	$I_{OH} = -400\ \mu A$	$V_{CC} - 2$		V	
$V_{OL}$	LOW Level Output Voltage	$V_{CC} = 4.5V$	$I_{OL} = 12\text{ mA}$		0.25	0.4	V
			$I_{OL} = 24\text{ mA}$		0.35	0.5	V
$I_I$	Input Current @ Maximum Input Voltage	$V_{CC} = 5.5V$ , $V_{IH} = 7V$			0.1	mA	
$I_{IH}$	HIGH Level Input Current	$V_{CC} = 5.5V$ , $V_{IH} = 2.7V$			20	$\mu A$	
$I_{IL}$	LOW Level Input Current	$V_{CC} = 5.5V$ , $V_{IL} = 0.4V$			-0.2	mA	
$I_O$	Output Drive Current	$V_{CC} = 5.5V$	$V_O = 2.25V$	-30	-112	mA	
$I_{CC}$	Supply Current	$V_{CC} = 5.5V$	Outputs HIGH		11	20	mA
			Outputs OPEN	Outputs LOW		19	29

**Switching Characteristics**

over recommended operating free air temperature range.

Symbol	Parameter	Conditions	From	To	Min	Max	Units
$f_{MAX}$	Maximum Clock Frequency	$V_{CC} = 4.5V$ to $5.5V$			35		MHz
$t_{PHL}$	Propagation Delay Time HIGH-to-LOW Level Output	$R_L = 500\ \Omega$ $C_L = 50\text{ pF}$	Clear	Any Q	4	18	ns
			Clock	Any Q	LOW-to-HIGH Level Output	2	12
Clock	Any Q				3	15	ns

**Physical Dimensions** inches (millimeters) unless otherwise noted

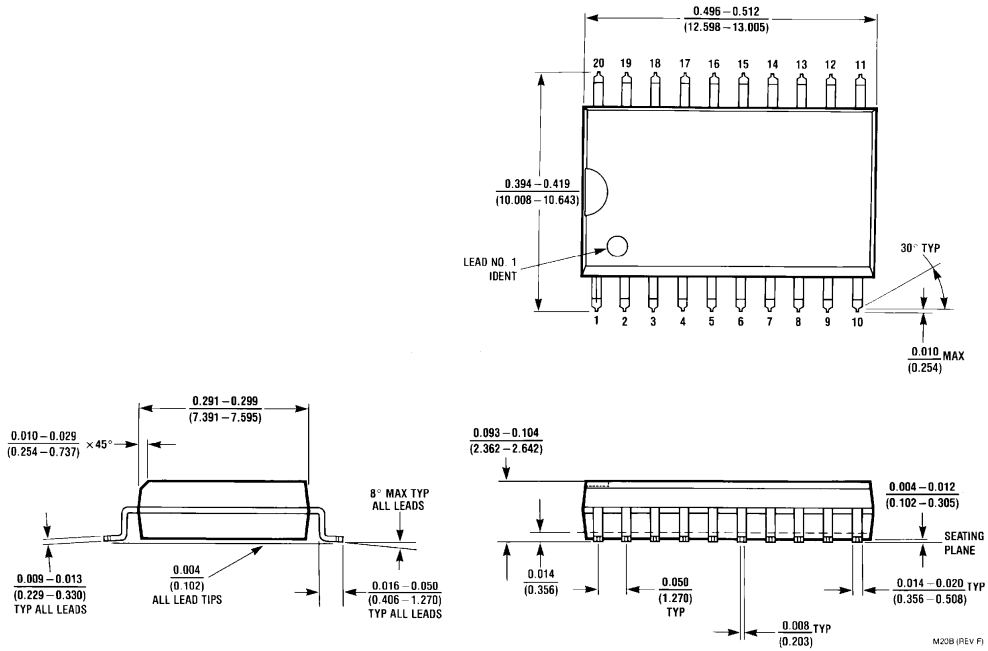

**20-Lead Small Outline Integrated Circuit (SOIC), JEDEC MS-013, 0.300 Wide  
Package Number M20B**

**Physical Dimensions** inches (millimeters) unless otherwise noted (Continued)

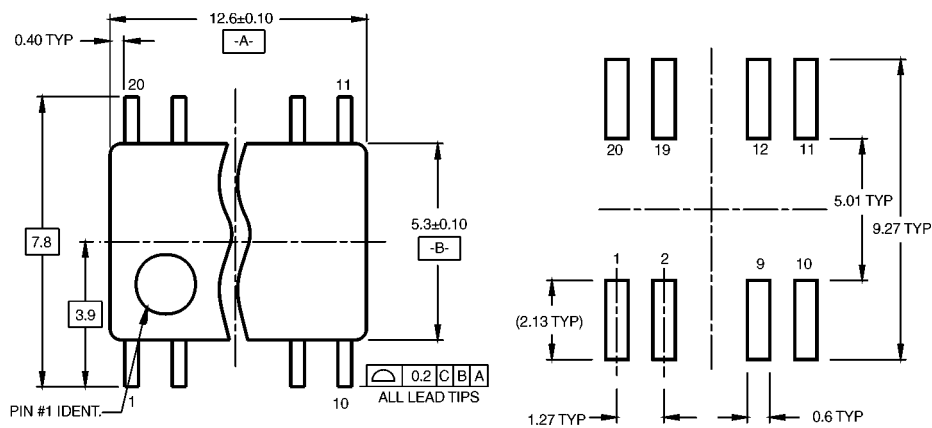

**LAND PATTERN RECOMMENDATION**

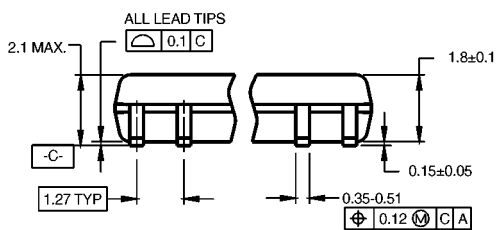

DIMENSIONS ARE IN MILLIMETERS

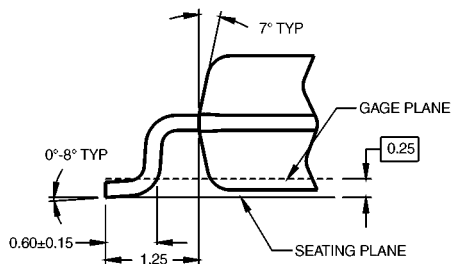
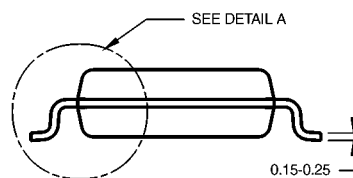

**DETAIL A**

- NOTES:
- A. CONFORMS TO EIAJ EDR-7320 REGISTRATION, ESTABLISHED IN DECEMBER, 1998.
  - B. DIMENSIONS ARE IN MILLIMETERS.
  - C. DIMENSIONS ARE EXCLUSIVE OF BURRS, MOLD FLASH, AND TIE BAR EXTRUSIONS.

M20DRevB1

**20-Lead Small Outline Package (SOP), EIAJ TYPE II, 5.3mm Wide  
Package Number M20D**

**Physical Dimensions** inches (millimeters) unless otherwise noted (Continued)

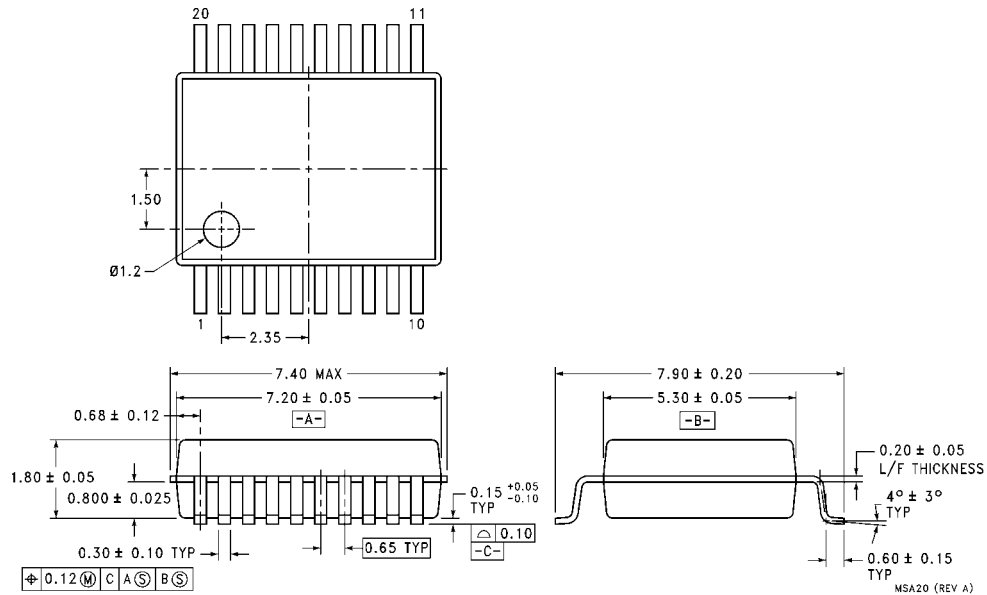

**20-Lead Shrink Small Outline Package (SSOP), EIAJ TYPE II, 5.3mm Wide  
Package Number MSA20**

**Physical Dimensions** inches (millimeters) unless otherwise noted (Continued)

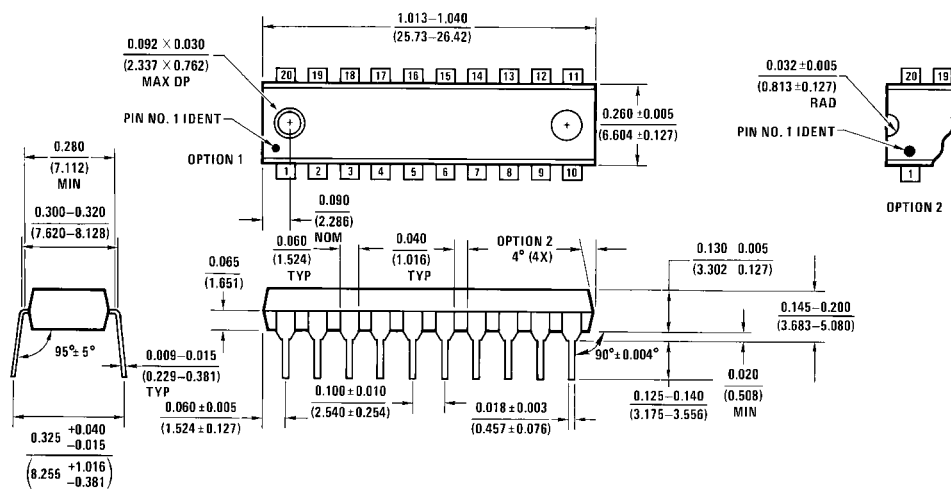

**20-Lead Plastic Dual-In-Line Package (PDIP), JEDEC MS-001, 0.300 Wide  
Package Number N20A**

Fairchild does not assume any responsibility for use of any circuitry described, no circuit patent licenses are implied and Fairchild reserves the right at any time without notice to change said circuitry and specifications.

**LIFE SUPPORT POLICY**

FAIRCHILD'S PRODUCTS ARE NOT AUTHORIZED FOR USE AS CRITICAL COMPONENTS IN LIFE SUPPORT DEVICES OR SYSTEMS WITHOUT THE EXPRESS WRITTEN APPROVAL OF THE PRESIDENT OF FAIRCHILD SEMICONDUCTOR CORPORATION. As used herein:

1. Life support devices or systems are devices or systems which, (a) are intended for surgical implant into the body, or (b) support or sustain life, and (c) whose failure to perform when properly used in accordance with instructions for use provided in the labeling, can be reasonably expected to result in a significant injury to the user.
2. A critical component in any component of a life support device or system whose failure to perform can be reasonably expected to cause the failure of the life support device or system, or to affect its safety or effectiveness.

[www.fairchildsemi.com](http://www.fairchildsemi.com)