



Chipsmall Limited consists of a professional team with an average of over 10 year of expertise in the distribution of electronic components. Based in Hongkong, we have already established firm and mutual-benefit business relationships with customers from,Europe,America and south Asia,supplying obsolete and hard-to-find components to meet their specific needs.

With the principle of "Quality Parts,Customers Priority,Honest Operation,and Considerate Service",our business mainly focus on the distribution of electronic components. Line cards we deal with include Microchip,ALPS,ROHM,Xilinx,Pulse,ON,Everlight and Freescale. Main products comprise IC,Modules,Potentiometer,IC Socket,Relay,Connector.Our parts cover such applications as commercial,industrial, and automotives areas.

We are looking forward to setting up business relationship with you and hope to provide you with the best service and solution. Let us make a better world for our industry!



Contact us

Tel: +86-755-8981 8866 Fax: +86-755-8427 6832

Email & Skype: info@chipsmall.com Web: www.chipsmall.com

Address: A1208, Overseas Decoration Building, #122 Zhenhua RD., Futian, Shenzhen, China



DM74ALS374

Octal 3-STATE D-Type Edge-Triggered Flip-Flop

General Description

This 8-bit register features totem-pole 3-STATE outputs designed specifically for driving highly-capacitive or relatively low-impedance loads. The high-impedance state and increased high-logic-level drive provides this register with the capability of being connected directly to and driving the bus lines in a bus-organized system without need for interface or pull-up components. It is particularly attractive for implementing buffer registers, I/O ports, bidirectional bus drivers, and working registers.

The eight flip-flops of the DM74ALS374 are edge-triggered D-type flip-flops. On the positive transition of the clock, the Q outputs will be set to the logic states that were set up at the D inputs.

A buffered output control input can be used to place the eight outputs in either a normal logic state (HIGH or LOW logic levels) or a high-impedance state. In the high-impedance state the outputs neither load nor drive the bus lines significantly.

The output control does not affect the internal operation of the flip-flops. That is, the old data can be retained or new data can be entered even while the outputs are OFF.

Features

- Switching specifications at 50 pF
- Switching specifications guaranteed over full temperature and V_{CC} range
- Advanced oxide-isolated, ion-implanted Schottky TTL process
- Functionally and pin-for-pin compatible with LS TTL counterpart
- Improved AC performance over DM74LS374 at approximately half the power
- 3-STATE buffer-type outputs drive bus lines directly

Ordering Code:

Order Number	Package Number	Package Description
DM74ALS374WM	M20B	20-Lead Small Outline Integrated Circuit (SOIC), JEDEC MS-013, 0.300 Wide
DM74ALS374SJ	M20D	20-Lead Small Outline Package (SOP), EIAJ TYPE II, 5.3mm Wide
DM74ALS374N	N20A	20-Lead Plastic Dual-In-Line Package (PDIP), JEDEC MS-001, 0.300 Wide

Device also available in Tape and Reel. Specify by appending suffix letter "X" to the ordering code.

Connection Diagram

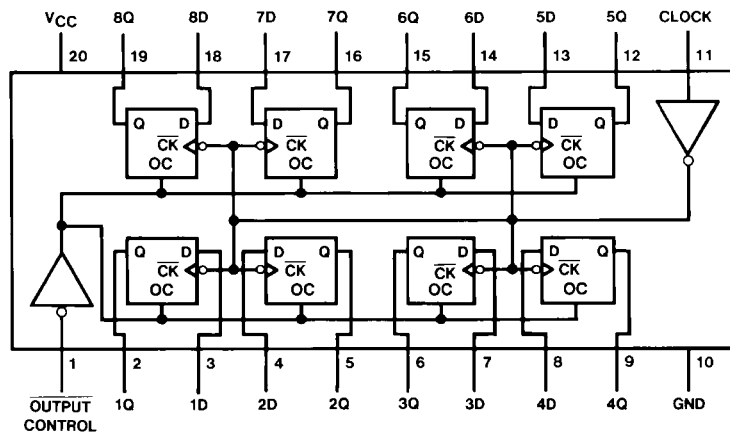

Function Table

Output Control	Clock	D	Output Q
L	↑	H	H
L	↑	L	L
L	L	X	Q ₀
H	X	X	Z

L = LOW State
 H = HIGH State
 X = Don't Care
 ↑ = Positive Edge Transition
 Z = High Impedance State
 Q₀ = Previous Condition of Q

Logic Diagram

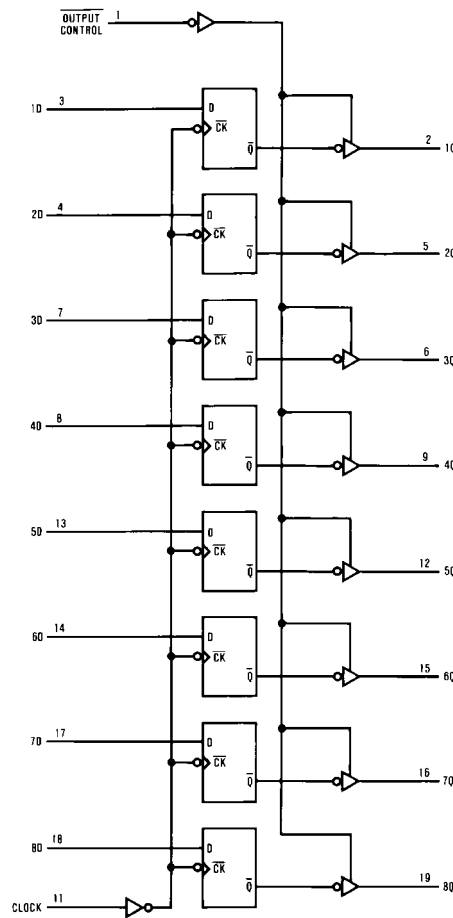

Absolute Maximum Ratings(Note 1)

Supply Voltage	7V
Input Voltage	7V
Voltage Applied to Disabled Output	5.5V
Operating Free Air Temperature Range	0°C to +70°C
Storage Temperature Range (Note 2)	-65°C to +150°C
Typical θ_{JA}	
N Package	60.0°C/W
M Package	79.0°C/W

Note 1: The "Absolute Maximum Ratings" are those values beyond which the safety of the device cannot be guaranteed. The device should not be operated at these limits. The parametric values defined in the Electrical Characteristics tables are not guaranteed at the absolute maximum ratings. The "Recommended Operating Conditions" table will define the conditions for actual device operation.

Note 2: This product meets application requirements of 500 temperature cycles from -65°C to +150°C.

Recommended Operating Conditions

Symbol	Parameter	Min	Nom	Max	Units
V_{CC}	Supply Voltage	4.5	5	5.5	V
V_{IH}	HIGH Level Input Voltage	2			V
V_{IL}	LOW Level Input Voltage			0.8	V
I_{OH}	HIGH Level Output Current			-2.6	mA
I_{OL}	LOW Level Output Current			24	mA
f_{CLOCK}	Clock Frequency	0		35	MHz
t_W	Width of Clock Pulse	HIGH	14		ns
		LOW	14		ns
t_{SU}	Data Setup Time (Note 3)	10 \uparrow			ns
t_H	Data Hold Time (Note 3)	0 \uparrow			ns
T_A	Free Air Operating Temperature	0		70	°C

Note 3: The (1) arrow indicates the positive edge of the Clock is used for reference.

DC Electrical Characteristics

over recommended operating free air temperature range. All typical values are measured at $V_{CC} = 5V$, $T_A = 25^\circ C$.

Symbol	Parameter	Conditions	Min	Typ	Max	Units
V_{IK}	Input Clamp Voltage	$V_{CC} = 4.5V$, $I_I = -18 mA$			-1.5	V
V_{OH}	HIGH Level Output Voltage	$V_{CC} = 4.5V$	$I_{OH} = \text{Max}$	2.4	3.2	V
		$V_{CC} = 4.5V$ to $5.5V$	$I_{OH} = -400 \mu A$	$V_{CC} - 2$		V
V_{OL}	LOW Level Output Voltage	$V_{CC} = 4.5V$	$I_{OL} = 12 mA$	0.25	0.4	V
			$I_{OL} = 24 mA$	0.35	0.5	V
I_I	Input Current @ Max. Input Voltage	$V_{CC} = 5.5V$, $V_{IH} = 7V$			0.1	mA
I_{IH}	HIGH Level Input Current	$V_{CC} = 5.5V$, $V_{IH} = 2.7V$			20	μA
I_{IL}	LOW Level Input Current	$V_{CC} = 5.5V$, $V_{IL} = 0.4V$			-0.2	mA
I_O	Output Drive Current	$V_{CC} = 5.5V$, $V_O = 2.25V$	-30		-112	mA
I_{OZH}	OFF-State Output Current, HIGH Level Voltage Applied	$V_{CC} = 5.5V$, $V_O = 2.7V$			20	μA
I_{OZL}	OFF-State Output Current, LOW Level Voltage Applied	$V_{CC} = 5.5V$, $V_O = 0.4V$			-20	μA
I_{CC}	Supply Current	$V_{CC} = 5.5V$ Outputs Open	Outputs HIGH	11	19	mA
			Outputs LOW	19	28	mA
			Outputs Disabled	20	31	mA

AC Electrical Characteristics

Symbol	Parameter	Conditions	From	To	Min	Max	Units
f_{MAX}	Maximum Clock Frequency	$V_{CC} = 4.5V$ to $5.5V$			35		MHz
t_{PLH}	Propagation Delay Time LOW-to-HIGH Level Output	$R_L = 500\Omega$ $C_L = 50$ pF	Clock	Any Q	3	12	ns
t_{PHL}	Propagation Delay Time HIGH-to-LOW Level Output		Clock	Any Q	5	16	ns
t_{PZH}	Output Enable Time to HIGH Level Output		Output Control	Any Q	5	17	ns
t_{PZL}	Output Enable Time to LOW Level Output		Output Control	Any Q	7	18	ns
t_{PHZ}	Output Disable Time from HIGH Level Output		Output Control	Any Q	2	10	ns
t_{PLZ}	Output Disable Time from LOW Level Output		Output Control	Any Q	3	18	ns

Physical Dimensions inches (millimeters) unless otherwise noted

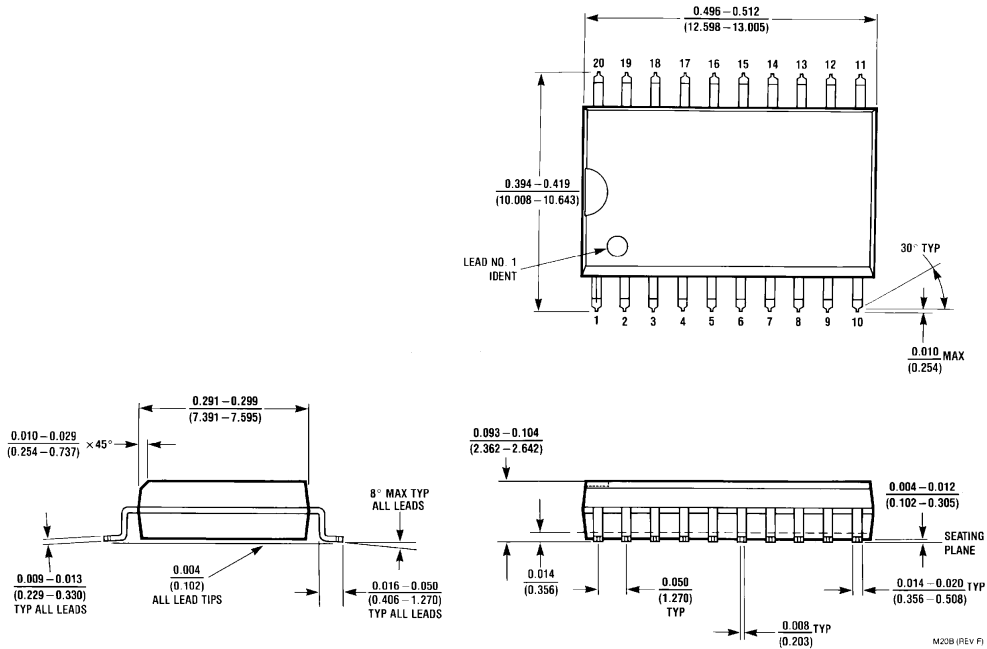

**20-Lead Small Outline Integrated Circuit (SOIC), JEDEC MS-013, 0.300 Wide
Package Number M20B**

Physical Dimensions inches (millimeters) unless otherwise noted (Continued)

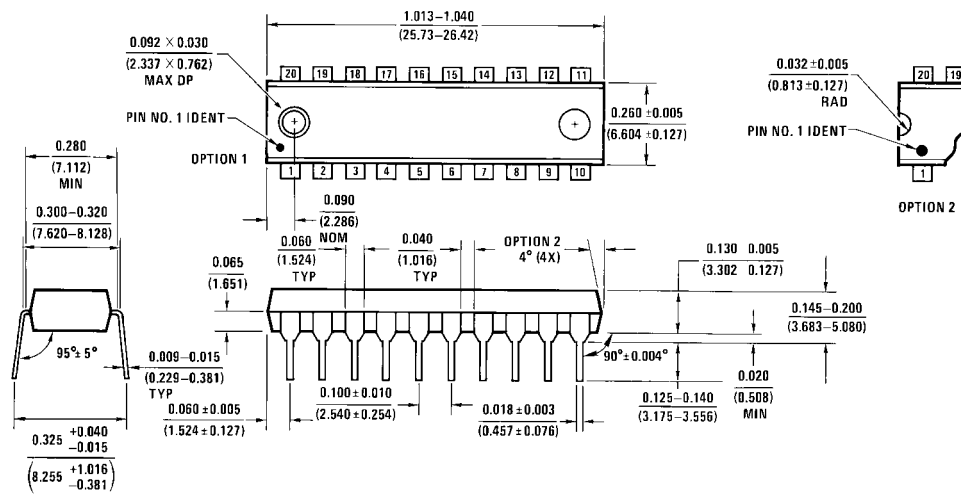

**20-Lead Plastic Dual-In-Line Package (PDIP), JEDEC MS-001, 0.300 Wide
Package Number N20A**

N20A (REV G)

Fairchild does not assume any responsibility for use of any circuitry described, no circuit patent licenses are implied and Fairchild reserves the right at any time without notice to change said circuitry and specifications.

LIFE SUPPORT POLICY

FAIRCHILD'S PRODUCTS ARE NOT AUTHORIZED FOR USE AS CRITICAL COMPONENTS IN LIFE SUPPORT DEVICES OR SYSTEMS WITHOUT THE EXPRESS WRITTEN APPROVAL OF THE PRESIDENT OF FAIRCHILD SEMICONDUCTOR CORPORATION. As used herein:

1. Life support devices or systems are devices or systems which, (a) are intended for surgical implant into the body, or (b) support or sustain life, and (c) whose failure to perform when properly used in accordance with instructions for use provided in the labeling, can be reasonably expected to result in a significant injury to the user.
2. A critical component in any component of a life support device or system whose failure to perform can be reasonably expected to cause the failure of the life support device or system, or to affect its safety or effectiveness.

www.fairchildsemi.com