



Chipsmall Limited consists of a professional team with an average of over 10 year of expertise in the distribution of electronic components. Based in Hongkong, we have already established firm and mutual-benefit business relationships with customers from,Europe,America and south Asia,supplying obsolete and hard-to-find components to meet their specific needs.

With the principle of "Quality Parts,Customers Priority,Honest Operation,and Considerate Service",our business mainly focus on the distribution of electronic components. Line cards we deal with include Microchip,ALPS,ROHM,Xilinx,Pulse,ON,Everlight and Freescale. Main products comprise IC,Modules,Potentiometer,IC Socket,Relay,Connector.Our parts cover such applications as commercial,industrial, and automotives areas.

We are looking forward to setting up business relationship with you and hope to provide you with the best service and solution. Let us make a better world for our industry!



Contact us

Tel: +86-755-8981 8866 Fax: +86-755-8427 6832

Email & Skype: info@chipsmall.com Web: www.chipsmall.com

Address: A1208, Overseas Decoration Building, #122 Zhenhua RD., Futian, Shenzhen, China



DM74AS157 • DM74AS158

Quad 1 of 2 Line Data Selector/Multiplexer

General Description

These data selectors/multiplexers contain inverters and drivers to supply full on-chip data selection to the four output gates. A separate STROBE input is provided. A 4-bit word is selected from one of two sources and is routed to the four outputs. The AS157 presents true data whereas the AS158 presents inverted data to minimize propagation delay time.

Features

- Switching specifications at 50 pF
- Switching specifications guaranteed over full temperature and V_{CC} range
- Advanced oxide-isolated, ion-implanted Schottky TTL process
- Functionally and pin for pin compatible with Schottky, low power Schottky, and advanced low power Schottky TTL counterpart
- Improved AC performance over Schottky, low power Schottky, and advanced low power Schottky counterparts
- Expand any data input point
- Multiplex dual data buses
- General four functions of two variables (one variable is common)
- Source programmable counters

Ordering Code:

Order Number	Package Number	Package Description
DM74AS157M	M16A	16-Lead Small Outline Integrated Circuit (SOIC), JEDEC MS-012, 0.150 Narrow
DM74AS157SjX	M16D	16-Lead Small Outline Package (SOP), EIAJ TYPE II, 5.3mm Wide
DM74AS157N	N16E	16-Lead Plastic Dual-In-Line Package (PDIP), JEDEC MS-001, 0.300 Wide
DM74AS158M	M16A	16-Lead Small Outline Integrated Circuit (SOIC), JEDEC MS-012, 0.150 Narrow
DM74AS158N	N16E	16-Lead Plastic Dual-In-Line Package (PDIP), JEDEC MS-001, 0.300 Wide

Devices also available in Tape and Reel. Specify by appending the suffix letter "X" to the ordering code.

Connection Diagram

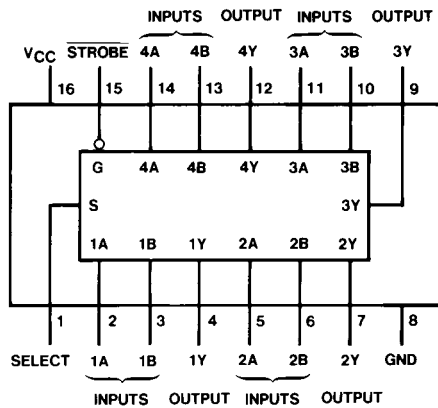

Function Table

STROBE	Inputs			Output Y	
	Select	A	B	DM74AS157	DM74AS158
H	X	X	X	L	H
L	L	L	X	L	H
L	L	H	X	H	L
L	H	X	L	L	H
L	H	X	H	H	L

H = HIGH Level
L = LOW Level
X = Don't Care

Logic Diagrams

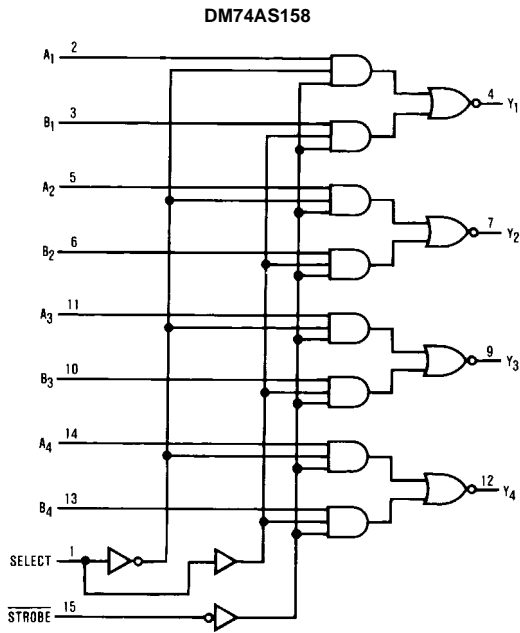
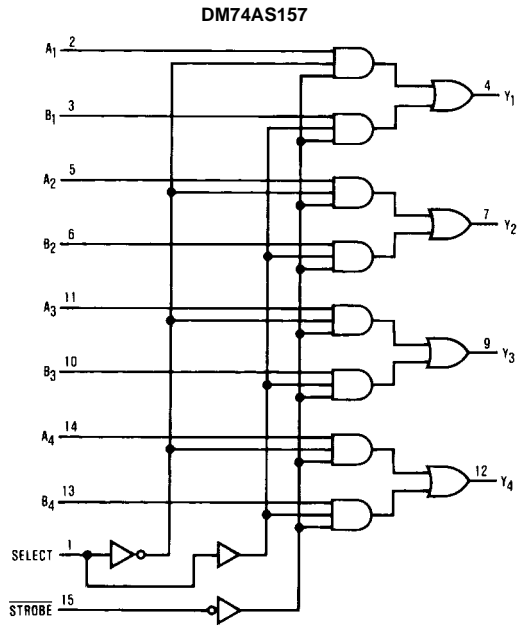

Absolute Maximum Ratings(Note 1)

Supply Voltage	7V
Input Voltage	7V
Operating Free Air Temperature Range	0°C to +70°C
Storage Temperature Range	-65°C to +150°C
Typical θ_{JA}	
N Package	75.0 °C/W

Note 1: The "Absolute Maximum Ratings" are those values beyond which the safety of the device cannot be guaranteed. The device should not be operated at these limits. The parametric values defined in the Electrical Characteristics tables are not guaranteed at the absolute maximum ratings. The "Recommended Operating Conditions" table will define the conditions for actual device operation.

Recommended Operating Conditions

Symbol	Parameter	Min	Nom	Max	Units
V_{CC}	Supply Voltage	4.5	5	5.5	V
V_{IH}	HIGH Level Input Voltage	2			V
V_{IL}	LOW Level Input Voltage			0.8	V
I_{OH}	HIGH Level Output Current			-2	mA
I_{OL}	LOW Level Output Current			20	mA
T_A	Free Air Operating Temperature	0		70	°C

Electrical Characteristics

over recommended operating free air temperature range. All typical values are measured at $V_{CC} = 5V$, $T_A = 25^\circ C$.

Symbol	Parameter	Conditions	Min	Typ	Max	Units
V_{IK}	Input Clamp Voltage	$V_{CC} = 4.5V$, $I_I = -18\text{ mA}$			-1.2	V
V_{OH}	HIGH Level Output Voltage	$V_{CC} = 4.5V$ to $5.5V$ $I_{OH} = -2\text{ mA}$	$V_{CC} - 2$			V
V_{OL}	LOW Level Output Voltage	$V_{CC} = 4.5V$ $I_{OL} = 20\text{ mA}$		0.35	0.5	V
I_I	Input Current at Max Input Voltage	$V_{CC} = 5.5V$ $V_{IH} = 7V$	Select All Others		0.2 0.1	mA
I_{IH}	HIGH Level Input Current	$V_{CC} = 5.5V$ $V_{IH} = 2.7V$	Select All Others		40 20	μA
I_{IL}	LOW Level Input Current	$V_{CC} = 5.5V$ $V_{IL} = 0.4V$	Select All Others		-1 -0.5	mA
I_O (Note 2)	Output Drive Current	$V_{CC} = 5.5V$, $V_O = 2.25V$	-30		-112	mA
I_{CC}	Supply Current	$V_{CC} = 5.5V$		17.5	28	mA
		DM74AS157				
		DM74AS158		15.6	22.5	mA

Note 2: The output conditions have been chosen to produce a current that closely approximates one half of the true short circuit current, I_{OS} .

DM74AS157 Switching Characteristics

over recommended operating free air temperature range

Symbol	Parameter	Conditions	From (Input)	To (Output)	Min	Max	Units
t_{PLH}	Propagation Delay Time, LOW-to-HIGH Level Output	$V_{CC} = 4.5V$ to $5.5V$, $C_L = 50$ pF, $R_L = 500\Omega$	Data	Y	1	6	ns
t_{PHL}	Propagation Delay Time, HIGH-to-LOW Level Output		Data	Y	1	5.5	ns
t_{PLH}	Propagation Delay Time, LOW-to-HIGH Level Output		$\overline{\text{STROBE}}$	Y	2	10.5	ns
t_{PHL}	Propagation Delay Time, HIGH-to-LOW Level Output		$\overline{\text{STROBE}}$	Y	2	7.5	ns
t_{PLH}	Propagation Delay Time, LOW-to-HIGH Level Output		Select	Y	2	11	ns
t_{PHL}	Propagation Delay Time, HIGH-to-LOW Level Output		Select	Y	2	10	ns

DM74AS158 Switching Characteristics

over recommended operating free air temperature range

Symbol	Parameter	Conditions	From (Input)	To (Output)	Min	Max	Units
t_{PLH}	Propagation Delay Time, LOW-to-HIGH Level Output	$V_{CC} = 4.5V$ to $5.5V$, $C_L = 50$ pF, $R_L = 500\Omega$	Data	Y	1	5	ns
t_{PHL}	Propagation Delay Time, HIGH-to-LOW Level Output		Data	Y	1	4.5	ns
t_{PLH}	Propagation Delay Time, LOW-to-HIGH Level Output		$\overline{\text{STROBE}}$	Y	2	6.5	ns
t_{PHL}	Propagation Delay Time, HIGH-to-LOW Level Output		$\overline{\text{STROBE}}$	Y	2	10	ns
t_{PLH}	Propagation Delay Time, LOW-to-HIGH Level Output		Select	Y	2	9.5	ns
t_{PHL}	Propagation Delay Time, HIGH-to-LOW Level Output		Select	Y	2	10.5	ns

Physical Dimensions inches (millimeters) unless otherwise noted

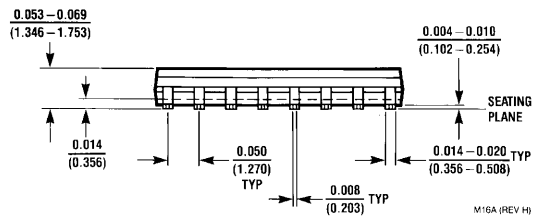
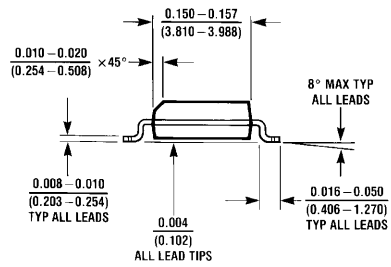
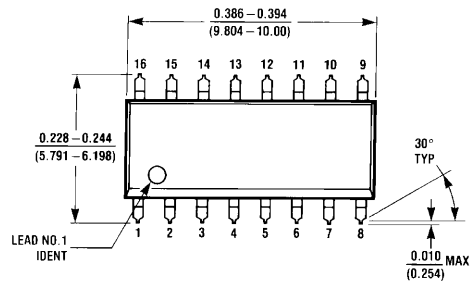

**16-Lead Small Outline Integrated Circuit (SOIC), JEDEC MS-012, 0.150 Narrow
Package Number M16A**

DM74AS157 • DM74AS158

Physical Dimensions inches (millimeters) unless otherwise noted (Continued)

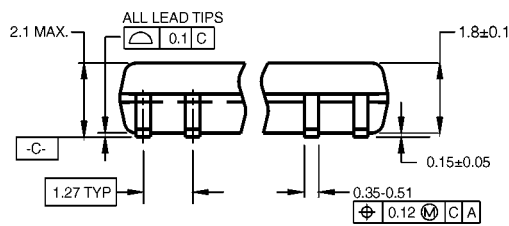
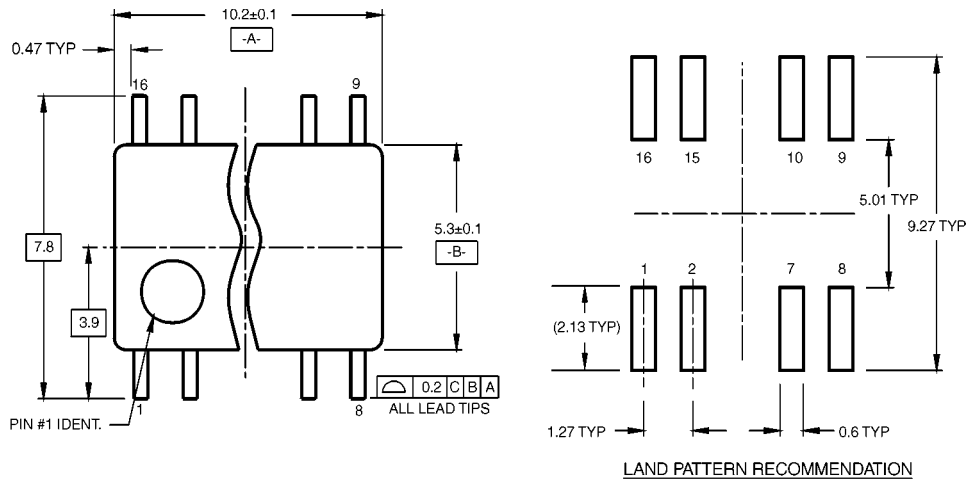

DIMENSIONS ARE IN MILLIMETERS

- NOTES:
 A. CONFORMS TO EIAJ EDR-7320 REGISTRATION, ESTABLISHED IN DECEMBER, 1998.
 B. DIMENSIONS ARE IN MILLIMETERS.
 C. DIMENSIONS ARE EXCLUSIVE OF BURRS, MOLD FLASH, AND TIE BAR EXTRUSIONS.

M16DRevB1

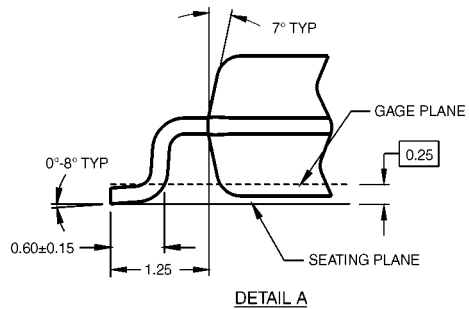
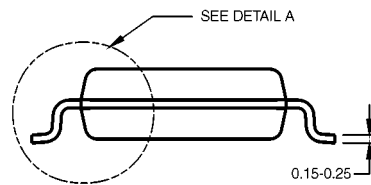

16-Lead Small Outline Package (SOP), EIAJ TYPE II, 5.3mm Wide Package Number M16D

Physical Dimensions inches (millimeters) unless otherwise noted (Continued)

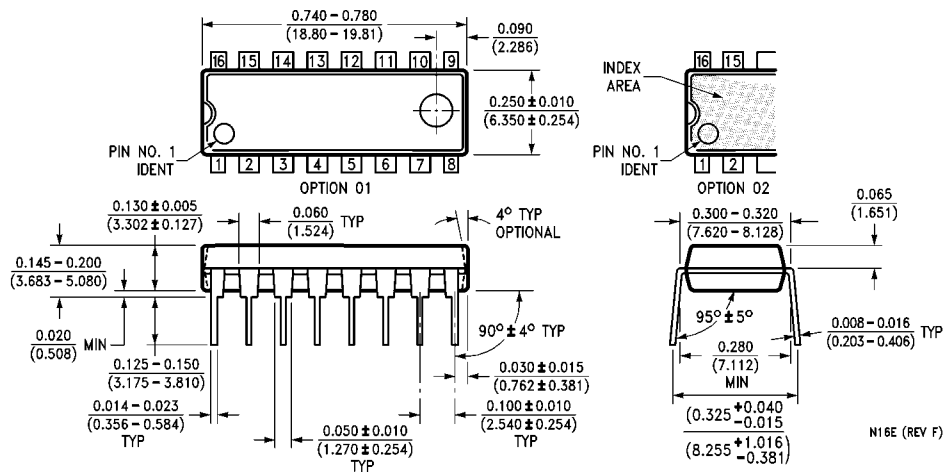

16-Lead Plastic Dual-In-Line Package (PDIP), JEDEC MS-001, 0.300 Wide Package Number N16E

Fairchild does not assume any responsibility for use of any circuitry described, no circuit patent licenses are implied and Fairchild reserves the right at any time without notice to change said circuitry and specifications.

LIFE SUPPORT POLICY

FAIRCHILD'S PRODUCTS ARE NOT AUTHORIZED FOR USE AS CRITICAL COMPONENTS IN LIFE SUPPORT DEVICES OR SYSTEMS WITHOUT THE EXPRESS WRITTEN APPROVAL OF THE PRESIDENT OF FAIRCHILD SEMICONDUCTOR CORPORATION. As used herein:

1. Life support devices or systems are devices or systems which, (a) are intended for surgical implant into the body, or (b) support or sustain life, and (c) whose failure to perform when properly used in accordance with instructions for use provided in the labeling, can be reasonably expected to result in a significant injury to the user.
2. A critical component in any component of a life support device or system whose failure to perform can be reasonably expected to cause the failure of the life support device or system, or to affect its safety or effectiveness.

www.fairchildsemi.com