



Chipsmall Limited consists of a professional team with an average of over 10 year of expertise in the distribution of electronic components. Based in Hongkong, we have already established firm and mutual-benefit business relationships with customers from,Europe,America and south Asia,supplying obsolete and hard-to-find components to meet their specific needs.

With the principle of "Quality Parts,Customers Priority,Honest Operation,and Considerate Service",our business mainly focus on the distribution of electronic components. Line cards we deal with include Microchip,ALPS,ROHM,Xilinx,Pulse,ON,Everlight and Freescale. Main products comprise IC,Modules,Potentiometer,IC Socket,Relay,Connector.Our parts cover such applications as commercial,industrial, and automotives areas.

We are looking forward to setting up business relationship with you and hope to provide you with the best service and solution. Let us make a better world for our industry!



## Contact us

Tel: +86-755-8981 8866 Fax: +86-755-8427 6832

Email & Skype: info@chipsmall.com Web: www.chipsmall.com

Address: A1208, Overseas Decoration Building, #122 Zhenhua RD., Futian, Shenzhen, China



## DM74AS240 • DM74AS244 3-STATE Bus Driver/Receiver

### General Description

This family of Advance Schottky 3-STATE Bus circuits are designed to provide either bidirectional or unidirectional buffer interface in Memory, Microprocessor, and Communication Systems. The output characteristics of the circuits have low impedance sufficient to drive terminated transmission lines down to 133Ω. The input characteristics of the circuits likewise have a high impedance so it will not significantly load the transmission line. The package contains eight 3-STATE buffers organized with four buffers having a common 3-STATE enable gate. The DM74AS240 and DM74AS244 are eight wide in a 20 pin package, and may be used as a 4 wide bidirectional or eight wide unidirectional. The buffer selection includes inverting and non-inverting, with enable or disable 3-STATE control.

### Features

- Advanced oxide-isolated, ion-implanted Schottky TTL process
- Improved switching performance with less power dissipation compared with Schottky counterpart
- Functional and pin compatible with 74LS and Schottky counterpart
- Switching response specified into 500Ω and 50 pF
- Specified to interface with CMOS at  $V_{OH} = V_{CC} - 2V$

### Ordering Code:

Order Number	Package Number	Package Description
DM74AS240WM	M20B	20-Lead Small Outline Integrated Circuit (SOIC), JEDEC MS-013, 0.300 Wide
DM74AS240N	N20A	20-Lead Plastic Dual-In-Line Package (PDIP), JEDEC MS-001, 0.300 Wide
DM74AS244WM	M20B	20-Lead Small Outline Integrated Circuit (SOIC), JEDEC MS-013, 0.300 Wide
DM74AS244N	N20A	20-Lead Plastic Dual-In-Line Package (PDIP), JEDEC MS-001, 0.300 Wide

Devices also available in Tape and Reel. Specify by appending the suffix letter "X" to the ordering code.

### Connection Diagrams

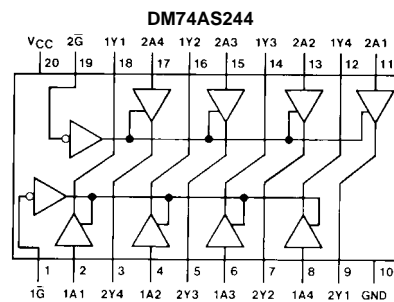
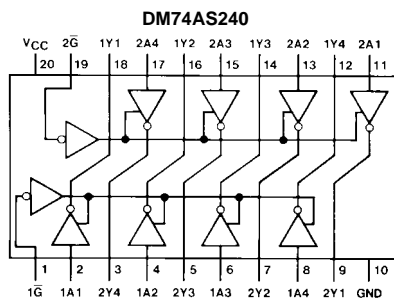

### Function Tables

DM74AS240

Inputs		Output
$\bar{G}$	A	Y
L	L	H
L	H	L
H	X	Z

L = LOW Logic Level    H = HIGH Logic Level    X = Either LOW or HIGH Logic Level    Z = High Impedance

DM74AS244

Inputs		Output
$\bar{G}$	A	Y
L	L	L
L	H	H
H	X	Z

**Absolute Maximum Ratings**(Note 1)

Supply Voltage, $V_{CC}$	7V
Input Voltage	7V
Voltage Applied to Disabled Output	5.5V
Operating Free Air Temperature Range	0°C to +70°C
Storage Temperature Range	-65°C to +150°C
Typical $\theta_{JA}$	
N Package	57.0°C/W
M Package	76.0°C/W

**Note 1:** The "Absolute Maximum Ratings" are those values beyond which the safety of the device cannot be guaranteed. The device should not be operated at these limits. The parametric values defined in the Electrical Characteristics tables are not guaranteed at the absolute maximum ratings. The "Recommended Operating Conditions" table will define the conditions for actual device operation.

**Recommended Operating Conditions**

Symbol	Parameter	Min	Nom	Max	Units
$V_{CC}$	Supply Voltage	4.5	5	5.5	V
$V_{IH}$	HIGH Level Input Voltage	2			V
$V_{IL}$	LOW Level Input Voltage			0.8	V
$I_{OH}$	HIGH Level Output Current			-15	mA
$I_{OL}$	LOW Level Output Current			64	mA
$T_A$	Free Air Operating Temperature	0		70	°C

**Electrical Characteristics**

over recommended operating free air temperature range. All typical values are measured at  $V_{CC} = 5V$ ,  $T_A = 25^\circ C$ .

Symbol	Parameter	Conditions			Min	Typ	Max	Units	
$V_{IK}$	Input Clamp Voltage	$V_{CC} = 4.5V$ , $I_{IN} = -18\text{ mA}$					-1.2	V	
$V_{OH}$	HIGH Level Output Voltage	$V_{CC} = 4.5V$ , $I_{OH} = -3\text{ mA}$			2.4	3.2		V	
		$V_{CC} = 4.5V$ , $I_{OH} = \text{Max}$			2.4				
		$I_{OH} = -2\text{ mA}$ , $V_{CC} = 4.5V$ to $5.5V$			$V_{CC}-2$				
$V_{OL}$	LOW Level Output Voltage	$V_{CC} = 4.5V$ , $I_{OL} = \text{Max}$				0.35	0.55	V	
$I_I$	Input Current at Max Input Voltage	$V_{CC} = 5.5V$	$V_{IN} = 7V$	Others			100	$\mu A$	
$I_{IH}$	HIGH Level Input Current	$V_{CC} = 5.5V$ , $V_{IN} = 2.7V$			Others			20	$\mu A$
$I_{IL}$	LOW Level Input Current	$V_{CC} = 5.5V$ , $V_{IN} = 0.4V$					-500	$\mu A$	
					AS240, (G, $\bar{G}$ ), (Control Inputs), DM74AS244 ( $\bar{G}$ )				
					DM74AS244 (A)				
$I_{OZH}$	HIGH Level 3-STATE Output Current	$V_{CC} = 5.5V$ , $V = 2.7V$					50	$\mu A$	
$I_{OZL}$	LOW Level 3-STATE Output Current	$V_{CC} = 5.5V$ , $V = 0.4V$			DM74AS240, DM74AS244			-50	$\mu A$
$I_O$ (Note 2)	Output Drive Current	$V_{CC} = 5.5V$ , $V_{OUT} = 2.25V$			-50	-115	-150	mA	
$I_{CC}$	DM74AS240 Supply Current	$V_{CC} = 5.5V$			Outputs HIGH			11	17
					Outputs LOW			51	75
					3-STATE			24	38
$I_{CC}$	DM74AS244 Supply Current	$V_{CC} = 5.5V$			Outputs HIGH			22	34
					Outputs LOW			60	90
					3-STATE			34	54

**Note 2:** The output conditions have been chosen to produce a current that closely approximates one half the true short-circuit output current,  $I_{OS}$ .

**DM74AS240 Switching Characteristics**

over recommended operating free air temperature range

Symbol	Parameter	Conditions	From (Input)	To (Output)	Min	Max	Units
t <sub>PLH</sub>	Propagation Delay Time LOW-to-HIGH Level Output	V <sub>CC</sub> = 4.5V to 5.5V R <sub>1</sub> = R <sub>2</sub> = 500Ω C <sub>L</sub> = 50 pF	A	Y	2	6.5	ns
t <sub>PHL</sub>	Propagation Delay Time HIGH-to-LOW Level Output		A	Y	2	5.7	ns
t <sub>PZL</sub>	Output Enable to LOW Level		$\overline{G}$	Y	2	9	ns
t <sub>PZH</sub>	Output Enable to HIGH Level		$\overline{G}$	Y	2	6.4	ns
t <sub>PLZ</sub>	Output Disable from LOW Level		$\overline{G}$	Y	2	9.5	ns
t <sub>PHZ</sub>	Output Disable from HIGH Level		$\overline{G}$	Y	2	5	ns

**DM74AS244 Switching Characteristics**

over recommended operating free air temperature range

Symbol	Parameter	Conditions	From (Input)	To (Output)	Min	Max	Units
t <sub>PLH</sub>	Propagation Delay Time LOW-to-HIGH Level Output	V <sub>CC</sub> = 4.5V to 5.5V R <sub>1</sub> = R <sub>2</sub> = 500Ω C <sub>L</sub> = 50 pF	A	Y	2	6.2	ns
t <sub>PHL</sub>	Propagation Delay Time HIGH-to-LOW Level Output		A	Y	2	6.2	ns
t <sub>PZL</sub>	Output Enable to LOW Level		$\overline{G}$	Y	2	7.5	ns
t <sub>PZH</sub>	Output Enable to HIGH Level		$\overline{G}$	Y	2	9	ns
t <sub>PLZ</sub>	Output Disable from LOW Level		$\overline{G}$	Y	2	9	ns
t <sub>PHZ</sub>	Output Disable from HIGH Level		$\overline{G}$	Y	2	6	ns

**Physical Dimensions** inches (millimeters) unless otherwise noted

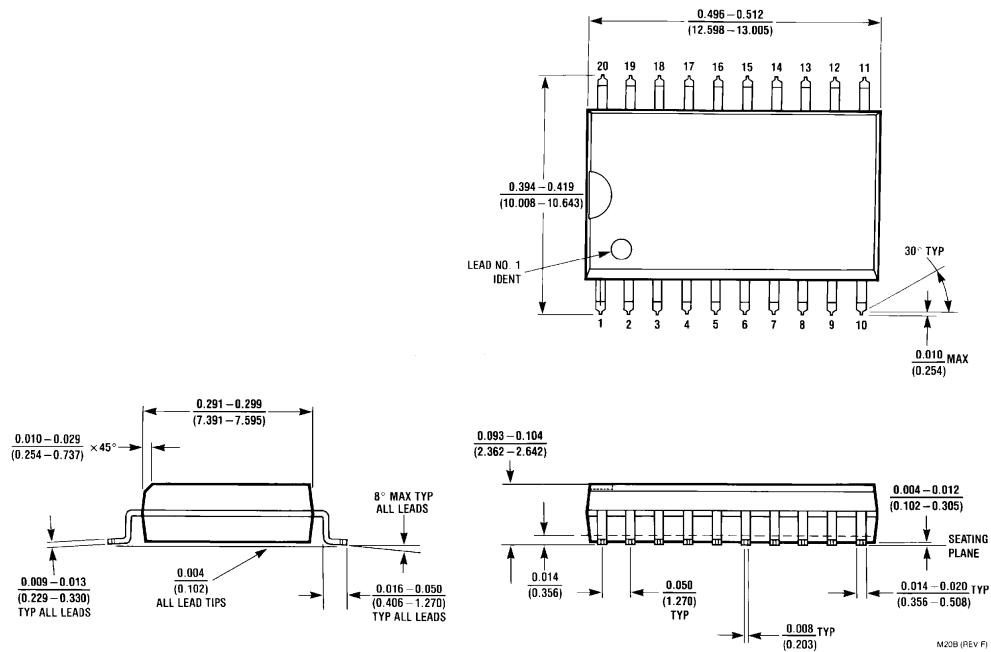

**20-Lead Small Outline Integrated Circuit (SOIC), JEDEC MS-013, 0.300 Wide  
Package Number M20B**

**Physical Dimensions** inches (millimeters) unless otherwise noted (Continued)

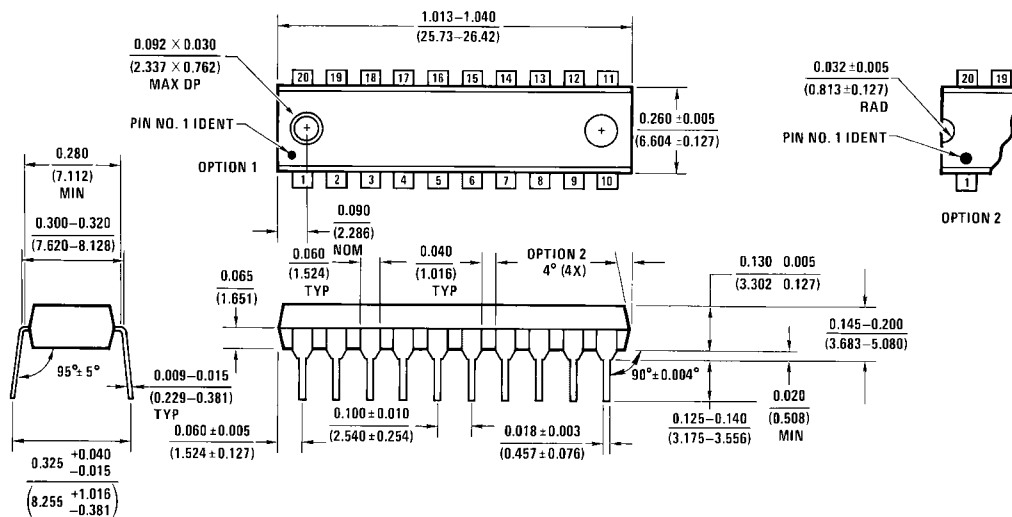

20-Lead Plastic Dual-In-Line Package (PDIP), JEDEC MS-001, 0.300 Wide Package Number N20A

N20A (REV G)

Fairchild does not assume any responsibility for use of any circuitry described, no circuit patent licenses are implied and Fairchild reserves the right at any time without notice to change said circuitry and specifications.

**LIFE SUPPORT POLICY**

FAIRCHILD'S PRODUCTS ARE NOT AUTHORIZED FOR USE AS CRITICAL COMPONENTS IN LIFE SUPPORT DEVICES OR SYSTEMS WITHOUT THE EXPRESS WRITTEN APPROVAL OF THE PRESIDENT OF FAIRCHILD SEMICONDUCTOR CORPORATION. As used herein:

1. Life support devices or systems are devices or systems which, (a) are intended for surgical implant into the body, or (b) support or sustain life, and (c) whose failure to perform when properly used in accordance with instructions for use provided in the labeling, can be reasonably expected to result in a significant injury to the user.
2. A critical component in any component of a life support device or system whose failure to perform can be reasonably expected to cause the failure of the life support device or system, or to affect its safety or effectiveness.

[www.fairchildsemi.com](http://www.fairchildsemi.com)