



Chipsmall Limited consists of a professional team with an average of over 10 year of expertise in the distribution of electronic components. Based in Hongkong, we have already established firm and mutual-benefit business relationships with customers from,Europe,America and south Asia,supplying obsolete and hard-to-find components to meet their specific needs.

With the principle of “Quality Parts,Customers Priority,Honest Operation,and Considerate Service”,our business mainly focus on the distribution of electronic components. Line cards we deal with include Microchip,ALPS,ROHM,Xilinx,Pulse,ON,Everlight and Freescale. Main products comprise IC,Modules,Potentiometer,IC Socket,Relay,Connector.Our parts cover such applications as commercial,industrial, and automotives areas.

We are looking forward to setting up business relationship with you and hope to provide you with the best service and solution. Let us make a better world for our industry!



Contact us

Tel: +86-755-8981 8866 Fax: +86-755-8427 6832

Email & Skype: info@chipsmall.com Web: www.chipsmall.com

Address: A1208, Overseas Decoration Building, #122 Zhenhua RD., Futian, Shenzhen, China



DM74AS245

Octal Bus Transceiver with 3-STATE Outputs

General Description

This advanced Schottky device contains 8 pairs of 3-STATE logic elements configured as octal bus transceivers. These circuits are designed for use in memory, micro-processor systems and in asynchronous bidirectional data buses. Two way communication between buses is controlled by the (DIR) input. Data transmits either from the A bus to the B bus or from the B bus to the A bus. Both the driver and receiver outputs can be disabled via the (\bar{G}) enable input which causes outputs to enter the high impedance mode so that the buses are effectively isolated.

Features

- Advanced oxide-isolated, ion-implanted Schottky TTL process
- Non-inverting logic output
- 3-STATE outputs independently controlled on A and B buses
- Low output impedance to drive terminated transmission lines to 133Ω
- Switching response specified into $500\Omega/50\text{ pF}$
- Specified to interface with CMOS at $V_{OH} = V_{CC} - 2V$
- PNP inputs reduce input loading
- Switching specifications guaranteed over full temperature and V_{CC} range

Ordering Code:

Order Number	Package Number	Package Description
DM74AS245WM	M20B	20-Lead Small Outline Integrated Circuit (SOIC), JEDEC MS-013, 0.300 Wide
DM74AS245SJ	M20D	20-Lead Small Outline Package (SOP), EIAJ TYPE II, 5.3mm Wide
DM74AS245N	N20A	20-Lead Plastic Dual-In-Line Package (PDIP), JEDEC MS-001, 0.300 Wide

Devices also available in Tape and Reel. Specify by appending the suffix letter "X" to the ordering code.

Connection Diagram

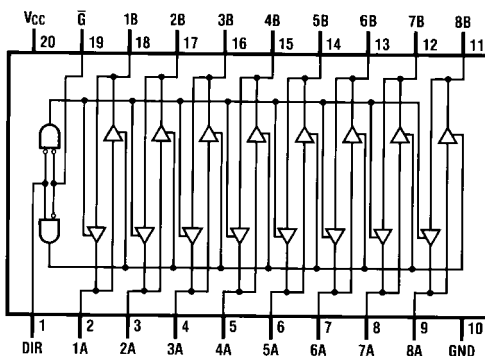

Function Table

Control Inputs		Operation
\bar{G}	DIR	
L	L	B Data to A Bus
L	H	A Data to B Bus
H	X	Hi-Z

Absolute Maximum Ratings(Note 1)

Supply Voltage, V_{CC}	7V
Input Voltage	
Control Inputs	7V
I/O Ports	5.5V
Operating Free Air Temperature Range	0°C to 70°C
Storage Temperature Range	-65°C to +150°C
Typical θ_{JA}	
N Package	51.5°C/W
M Package	76.0°C/W

Note 1: The "Absolute Maximum Ratings" are those values beyond which the safety of the device cannot be guaranteed. The device should not be operated at these limits. The parametric values defined in the Electrical Characteristics tables are not guaranteed at the absolute maximum ratings. The "Recommended Operating Conditions" table will define the conditions for actual device operation.

Recommended Operating Conditions

Symbol	Parameter	Min	Typ	Max	Units
V_{CC}	Supply Voltage	4.5	5	5.5	V
V_{IH}	HIGH Level Input Voltage	2			V
V_{IL}	LOW Level Input Voltage			0.8	V
I_{OH}	HIGH Level Output Current			-15	mA
I_{OL}	LOW Level Output Current			48	mA
T_A	Free Air Operating Temperature	0		70	°C

Electrical Characteristics

over recommended operating free air temperature range

Symbol	Parameter	Conditions	Min	Typ	Max	Units	
V_{IK}	Input Clamp Voltage	$V_{CC} = 4.5V, I_{IN} = -18\text{ mA}$			-1.2	V	
V_{OH}	HIGH Level Output Voltage	$V_{CC} = 4.5V, I_{OH} = -3\text{ mA}$	2.4	3.2		V	
		$V_{CC} = 4.5V, I_{OH} = -15\text{ mA}$	2	2.3			
		$I_{OH} = -2\text{ mA}, V_{CC} = 4.5V\text{ to }5.5V$	$V_{CC} - 2$				
V_{OL}	LOW Level Output Voltage	$V_{CC} = 4.5V, I_{OL} = \text{Max}$		0.35	0.55	V	
I_I	Input Current at Max Input Voltage	$V_{CC} = 5.5V, V_{IN} = 7V,$ ($V_{IN} = 5.5V$ for A or B Ports)			0.1	mA	
I_{IH}	HIGH Level Input Current	$V_{CC} = 5.5V,$ $V_{IN} = 2.7V$	Control Inputs		20	μA	
			A or B Ports		70		
I_{IL}	LOW Level Input Current	$V_{CC} = 5.5V,$ $V_{IN} = 0.4V$	Control Inputs		-0.5	mA	
			A or B Ports		-0.75		
I_O	Output Drive Current	$V_{CC} = 5.5V, V_{OUT} = 2.25V$	-50		-150	mA	
I_{CC}	Supply Current	$V_{CC} = 5.5V$	Output HIGH		62	97	mA
			Output LOW		95	149	
			3-STATE		79	123	

Switching Characteristics

over recommended operating free air temperature range

Symbol	Parameter	Conditions	From	To	Min	Max	Units
t_{PLH}	Propagation Delay Time HIGH-to-LOW Level Output	$V_{CC} = 4.5V\text{ to }5.5V,$ $R_1 = R_2 = 500\Omega,$ $C_L = 50\text{ pF}$	A or B	B or A	2	7.5	ns
t_{PHL}	Propagation Delay Time HIGH-to-LOW Level Output		A or B	B or A	2	7	ns
t_{PZL}	Output Enable Time to LOW Level		\overline{G}	A or B	2	8.5	ns
t_{PZH}	Output Enable Time to HIGH Level		\overline{G}	A or B	2	9	ns
t_{PLZ}	Output Disable Time from LOW Level		\overline{G}	A or B	2	9.5	ns
t_{PHZ}	Output Disable Time from HIGH Level		\overline{G}	A or B	2	5.5	ns

Physical Dimensions inches (millimeters) unless otherwise noted

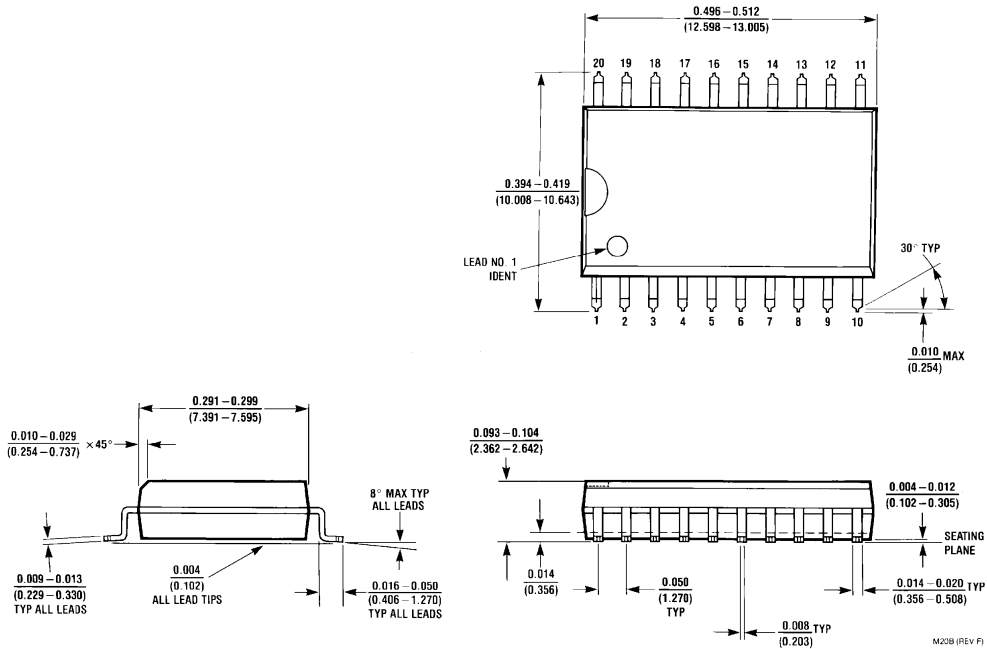

20-Lead Small Outline Integrated Circuit (SOIC), JEDEC MS-013, 0.300 Wide Package Number M20B

M20B (REV F)

Physical Dimensions inches (millimeters) unless otherwise noted (Continued)

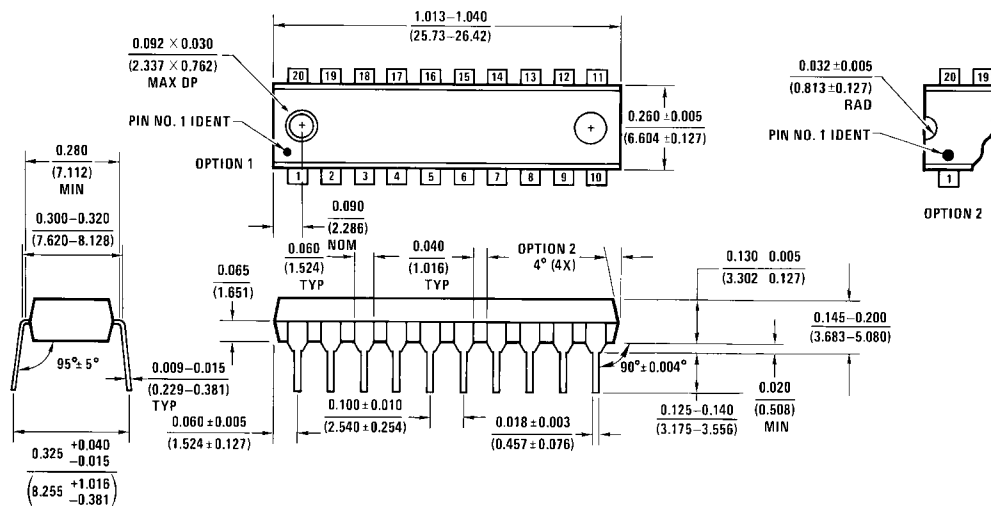

**20-Lead Plastic Dual-In-Line Package (PDIP), JEDEC MS-001, 0.300 Wide
Package Number N20A**

N20A (REV G)

Fairchild does not assume any responsibility for use of any circuitry described, no circuit patent licenses are implied and Fairchild reserves the right at any time without notice to change said circuitry and specifications.

LIFE SUPPORT POLICY

FAIRCHILD'S PRODUCTS ARE NOT AUTHORIZED FOR USE AS CRITICAL COMPONENTS IN LIFE SUPPORT DEVICES OR SYSTEMS WITHOUT THE EXPRESS WRITTEN APPROVAL OF THE PRESIDENT OF FAIRCHILD SEMICONDUCTOR CORPORATION. As used herein:

1. Life support devices or systems are devices or systems which, (a) are intended for surgical implant into the body, or (b) support or sustain life, and (c) whose failure to perform when properly used in accordance with instructions for use provided in the labeling, can be reasonably expected to result in a significant injury to the user.
2. A critical component in any component of a life support device or system whose failure to perform can be reasonably expected to cause the failure of the life support device or system, or to affect its safety or effectiveness.

www.fairchildsemi.com