



Chipsmall Limited consists of a professional team with an average of over 10 year of expertise in the distribution of electronic components. Based in Hongkong, we have already established firm and mutual-benefit business relationships with customers from,Europe,America and south Asia,supplying obsolete and hard-to-find components to meet their specific needs.

With the principle of “Quality Parts,Customers Priority,Honest Operation,and Considerate Service”,our business mainly focus on the distribution of electronic components. Line cards we deal with include Microchip,ALPS,ROHM,Xilinx,Pulse,ON,Everlight and Freescale. Main products comprise IC,Modules,Potentiometer,IC Socket,Relay,Connector.Our parts cover such applications as commercial,industrial, and automotives areas.

We are looking forward to setting up business relationship with you and hope to provide you with the best service and solution. Let us make a better world for our industry!



Contact us

Tel: +86-755-8981 8866 Fax: +86-755-8427 6832

Email & Skype: info@chipsmall.com Web: www.chipsmall.com

Address: A1208, Overseas Decoration Building, #122 Zhenhua RD., Futian, Shenzhen, China



DM74AS286

9-Bit Parity Generator/Checker with Bus-Driver Parity I/O Port

General Description

These universal, 9-bit parity generators/checkers utilize advanced Schottky high performance circuitry and feature odd/even outputs to facilitate operation of either odd or even parity applications. The word length capability is easily expanded by cascading.

The DM74AS286 can be used to upgrade the performance of most systems utilizing the DM74AS280 parity generator/checker. Although the DM74AS286 is implemented without expander inputs, the corresponding function is provided by the availability of an input pin $\overline{\text{XMIT}}$. $\overline{\text{XMIT}}$ is a control line which makes parity error output active and parity an input port when HIGH; when LOW, parity error output is inactive and parity becomes an output port. In addition, parity I/O control circuitry contains a feature to keep the I/O port in the 3-STATE during power UP or DOWN to prevent bus glitches.

Features

- PNP inputs to reduce bus loading
- Generates either odd or even parity for nine data lines
- Inputs are buffered to lower the drive requirements
- Can be used to upgrade existing systems using MSI parity circuits
- Cascadable for n-bits
- Switching specifications at 50 pF
- Switching specifications guaranteed over full temperature and V_{CC} range
- A parity I/O portable to drive bus

Ordering Code:

Order Number	Package Number	Package Description
DM74AS286M	M14A	14-Lead Small Outline Integrated Circuit (SOIC), JEDEC MS-120, 0.150 Narrow
DM74AS286N	N14A	14-Lead Plastic Dual-In-Line Package (PDIP), JEDEC MS-001, 0.300 Wide

Devices also available in Tape and Reel. Specify by appending the suffix letter "X" to the ordering code.

Connection Diagram

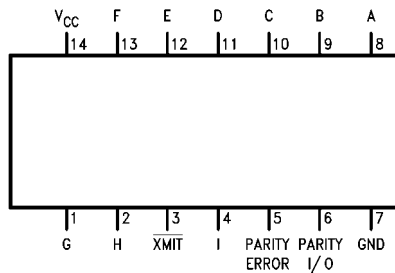

Function Table

Number of Inputs (A thru I) that are HIGH	Parity I/O		$\overline{\text{XMIT}}$	Parity Error	Mode of Operation
	Input	Output			
0, 2, 4, 6, 8	N/A	H	L	H	Parity Generator
1, 3, 5, 7, 9	N/A	L	L	H	Parity Checker
0, 2, 4, 6, 8	H	N/A	H	H	Parity Generator
0, 2, 4, 6, 8	L	N/A	H	L	Parity Checker
1, 3, 5, 7, 9	H	N/A	H	L	Parity Generator
1, 3, 5, 7, 9	L	N/A	H	H	Parity Checker

L = LOW Logic Level
H = HIGH Logic Level
N/A = Not Applicable

Absolute Maximum Ratings(Note 1)

Supply Voltage	7V
Input Voltage	7V
Operating Free Air Temperature Range	0°C to +70°C
Storage Temperature Range	-65°C to +150°C
Typical θ_{JA}	
N Package	77.0°C/W
M Package	108.0°C/W

Note 1: The "Absolute Maximum Ratings" are those values beyond which the safety of the device cannot be guaranteed. The device should not be operated at these limits. The parametric values defined in the Electrical Characteristics tables are not guaranteed at the absolute maximum ratings. The "Recommended Operating Conditions" table will define the conditions for actual device operation.

Recommended Operating Conditions

Symbol	Parameter	Min	Typ	Max	Units
V_{CC}	Supply Voltage	4.5	5	5.5	V
V_{IH}	HIGH Level Input Voltage	2			V
V_{IL}	LOW Level Input Voltage			0.8	V
I_{OH}	HIGH Level Output Current	Parity I/O		-15	mA
		Parity Error		-2	mA
I_{OL}	LOW Level Output Current	Parity I/O		48	mA
		Parity Error		20	mA
T_A	Operating Free-Air Temperature	0		70	°C

Electrical Characteristics

over recommended free-air temperature range. All typical values are measured at $V_{CC} = 5V$, $T_A = 25^\circ C$.

Symbol	Parameter	Conditions	Min	Typ	Max	Units
V_{IK}	Input Clamp Voltage	$V_{CC} = 4.5V$, $I_{IN} = -18 mA$			-1.2	V
V_{OH}	HIGH Level	$I_{OH} = Max$, $V_{CC} = 4.5V$	2.4	3.2		V
	Output Voltage	$V_{CC} = 4.5V$ to $5.5V$, $I_{OH} = -2 mA$	$V_{CC} - 2$			V
V_{OL}	LOW Level Output Voltage	$V_{CC} = 4.5V$, $I_{OL} = Max$		0.35	0.5	V
I_I	Input Current at Maximum Input Voltage	$V_{CC} = 5.5V$, $V_{IH} = 7V$ ($V_I = 5.5V$ for Parity I/O)			0.1	mA
I_{IH}	HIGH Level Input Current	$V_{CC} = 5.5V$	Others		20	μA
		$V_{IH} = 2.7V$ (Note 2)	Parity I/O		50	
I_{IL}	LOW Level Input Current	$V_{CC} = 5.5V$, $V_{IL} = 0.4V$ (Note 2)			-0.5	mA
I_O	Output Drive Current	$V_{CC} = 5.5V$, $V_{OUT} = 2.25V$	-30		-112	mA
I_{CC}	Supply Current	$V_{CC} = 5.5V$, Transmit Mode XMIT = LOW			43	mA
		Receive Mode XMIT = HIGH			50	mA

Note 2: For I/O ports, the parameters I_{IH} and I_{IL} include the OFF-state current, I_{OZH} and I_{OZL} .

Switching Characteristics						
over recommended supply and temperature range						
Symbol	Parameter	From	To	Min	Max	Units
t _{PLH}	Propagation Delay Time from LOW-to-HIGH Level Output	Any Data Input	Parity I/O	3	15	ns
t _{PHL}	Propagation Delay Time from HIGH-to-LOW Level Output	Any Data Input	Parity I/O	3	14	ns
t _{PLH}	Propagation Delay Time from LOW-to-HIGH Level Output	Any Data Input	Parity Error	3	16.5	ns
t _{PHL}	Propagation Delay Time from HIGH-to-LOW Level Output	Any Data Input	Parity Error	3	16.5	ns
t _{PLH}	Propagation Delay Time from LOW-to-HIGH Level Output	Parity I/O	Parity Error	3	9	ns
t _{PHL}	Propagation Delay Time from HIGH-to-LOW Level Output	Parity I/O	Parity Error	3	9	ns
t _{PZL}	Output Enable Time to LOW Level	XMIT	Parity I/O	3	16	ns
t _{PLZ}	Output Disable Time from LOW Level	XMIT	Parity I/O	3	10	ns
t _{PZH}	Output Disable Time from HIGH Level	XMIT	Parity I/O	3	13	ns
t _{PHZ}	Output Enable Time to HIGH Level	XMIT	Parity I/O	3	11.5	ns

Typical Applications

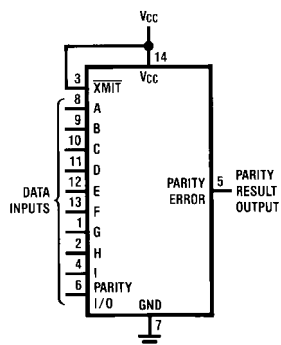

Number of Inputs that are Logic "1"	Parity Result Output
0, 2, 4, 6, 8, 10	Even L
1, 3, 5, 7, 9	Odd H

FIGURE 1. Dedicated 10-Bit Parity Sensing Configuration

Typical Applications (Continued)

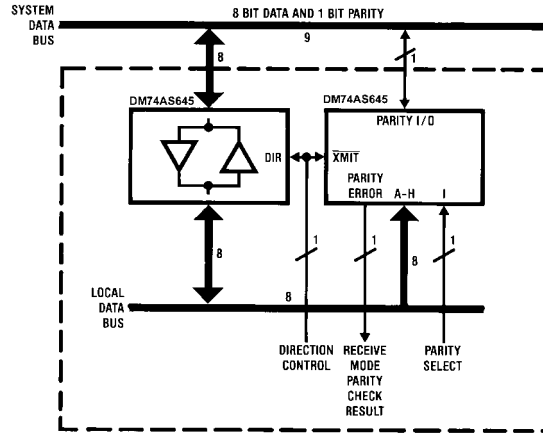

Direction Control (XMIT)	I/O Direction (Parity I/O)	Parity Check Result (Parity Error)	
		Level	Σ Result
H	Input (Receive)	H	True
		L	False
L	Output (Transmit)	H	N/A

Parity Select (Input I)	
Level	Format
H	Even
L	Odd

L = LOW Logic Level
 H = HIGH Logic Level
 N/A = Not Applicable

FIGURE 2. Bus I/O Parity Implementation

Typical Applications (Continued)

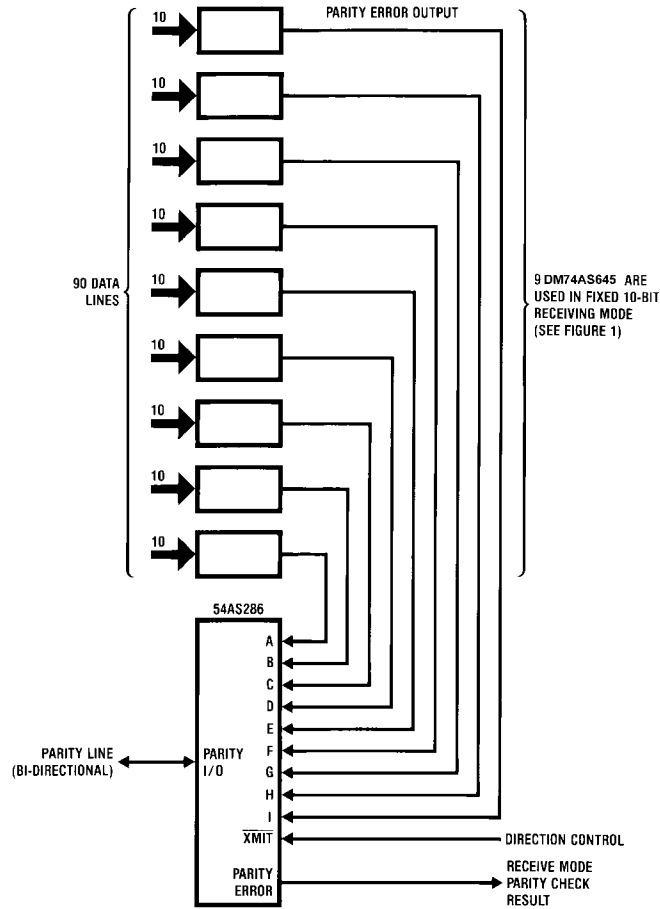

Note: Parity format in this configuration is "odd parity"

FIGURE 3. 90-Bit Parity Generator/Checker Implementation Using Device Expansion Techniques

Physical Dimensions inches (millimeters) unless otherwise noted

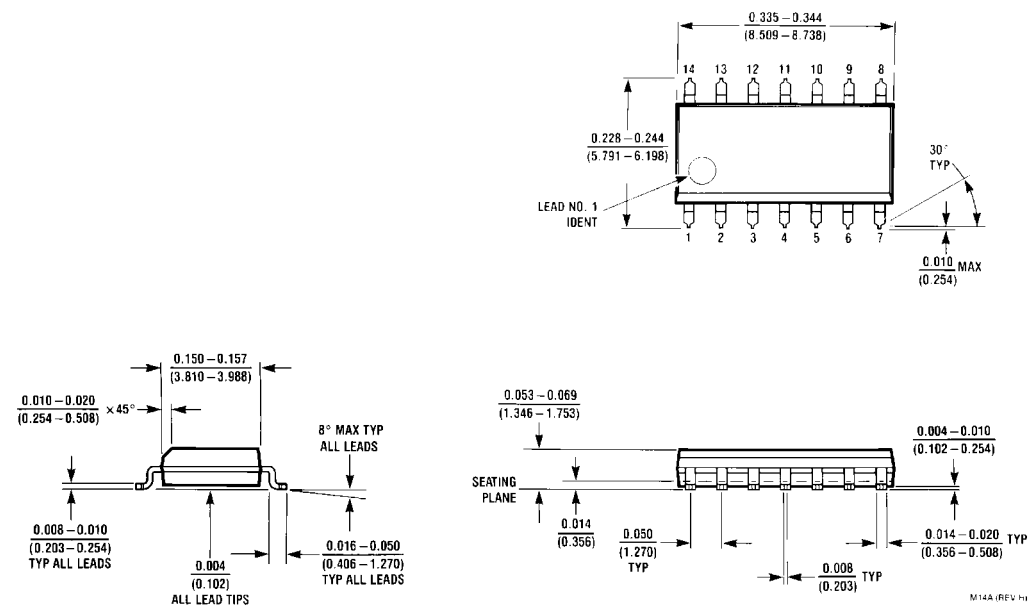

**14-Lead Small Outline Integrated Circuit (SOIC), JEDEC MS-120, 0.150 Narrow
Package Number M14A**

Physical Dimensions inches (millimeters) unless otherwise noted (Continued)

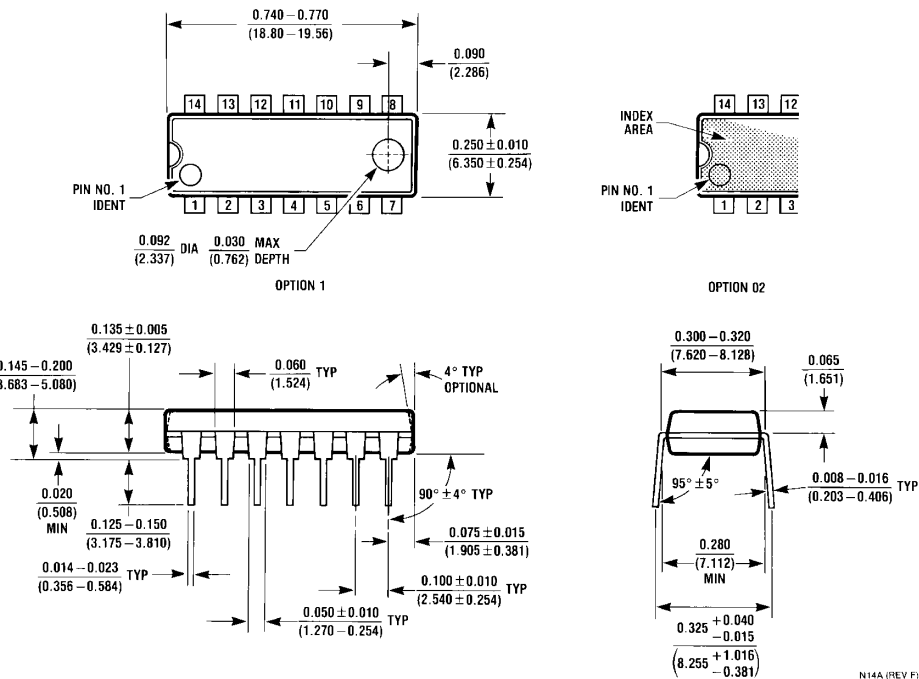

Fairchild does not assume any responsibility for use of any circuitry described, no circuit patent licenses are implied and Fairchild reserves the right at any time without notice to change said circuitry and specifications.

LIFE SUPPORT POLICY

FAIRCHILD'S PRODUCTS ARE NOT AUTHORIZED FOR USE AS CRITICAL COMPONENTS IN LIFE SUPPORT DEVICES OR SYSTEMS WITHOUT THE EXPRESS WRITTEN APPROVAL OF THE PRESIDENT OF FAIRCHILD SEMICONDUCTOR CORPORATION. As used herein:

1. Life support devices or systems are devices or systems which, (a) are intended for surgical implant into the body, or (b) support or sustain life, and (c) whose failure to perform when properly used in accordance with instructions for use provided in the labeling, can be reasonably expected to result in a significant injury to the user.
2. A critical component in any component of a life support device or system whose failure to perform can be reasonably expected to cause the failure of the life support device or system, or to affect its safety or effectiveness.

www.fairchildsemi.com