



Chipsmall Limited consists of a professional team with an average of over 10 year of expertise in the distribution of electronic components. Based in Hongkong, we have already established firm and mutual-benefit business relationships with customers from,Europe,America and south Asia,supplying obsolete and hard-to-find components to meet their specific needs.

With the principle of “Quality Parts,Customers Priority,Honest Operation,and Considerate Service”,our business mainly focus on the distribution of electronic components. Line cards we deal with include Microchip,ALPS,ROHM,Xilinx,Pulse,ON,Everlight and Freescale. Main products comprise IC,Modules,Potentiometer,IC Socket,Relay,Connector.Our parts cover such applications as commercial,industrial, and automotives areas.

We are looking forward to setting up business relationship with you and hope to provide you with the best service and solution. Let us make a better world for our industry!



Contact us

Tel: +86-755-8981 8866 Fax: +86-755-8427 6832

Email & Skype: info@chipsmall.com Web: www.chipsmall.com

Address: A1208, Overseas Decoration Building, #122 Zhenhua RD., Futian, Shenzhen, China



DM74AS573

Octal D-Type Transparent Latch with 3-STATE Outputs

General Description

These 8-bit registers feature totem-pole 3-STATE outputs designed specifically for driving highly-capacitive or relatively low-impedance loads. The high-impedance state and increased HIGH-logic-level drive provide these registers with the capability of being connected directly to and driving the bus lines in a bus-organized system without need for interface or pull-up components. They are particularly attractive for implementing buffer registers, I/O ports, bidirectional bus drivers, and working registers.

The eight latches of the DM74AS573 are transparent D-type latches, meaning that while the enable (G) is HIGH the Q outputs will follow the data (D) inputs. When the enable is taken LOW the output will be latched at the level of the data that was set UP.

A buffered output control input can be used to place the eight outputs in either a normal logic state (HIGH or LOW logic levels) or a high-impedance state. In the high-impedance state the outputs neither load nor drive the bus lines significantly.

The output control does not affect the internal operation of the latches. That is, the old data can be retained or new data can be entered even while the outputs are OFF.

The pin-out is arranged to ease printed circuit board layout. All data inputs are on one side of the package while all the outputs are on the other side.

Features

- Switching specifications at 50 pF
- Switching specifications guaranteed over full temperature and V_{CC} range
- Advanced oxide-isolated, ion-implanted Schottky TTL process
- Functionally equivalent with DM74S373
- Improved AC performance over DM74S373 at approximately half the power
- 3-STATE buffer-type outputs drive bus lines directly
- Bus structured pinout

Ordering Code:

Order Number	Package Number	Package Description
DM74AS573WM	M20B	20-Lead Small Outline Integrated Circuit (SOIC), JEDEC MS-013, 0.300 Wide
DM74AS573N	N20A	20-Lead Plastic Dual-In-Line Package (PDIP), JEDEC MS-001, 0.300 Wide

Devices also available in Tape and Reel. Specify by appending the suffix letter "X" to the ordering code.

Connection Diagram

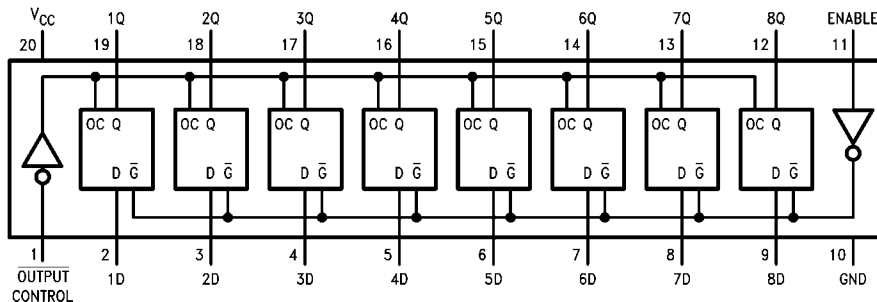

Function Table

Output Control	Enable		Output Q
	G	D	
L	H	H	H
L	H	L	L
L	L	X	Q ₀
H	X	X	Z

L = LOW State
 H = HIGH State
 X = Don't Care
 Z = High Impedance State
 Q₀ = Previous Condition of Q

Logic Diagram

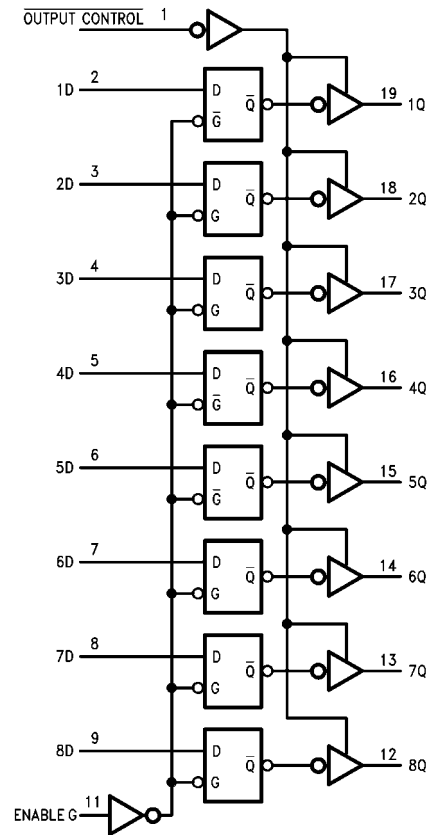

Absolute Maximum Ratings(Note 1)

Supply Voltage	7V
Input Voltage	7V
Voltage Applied to Disabled Output	5.5V
Operating Free Air Temperature Range	0°C to +70°C
Storage Temperature Range	-65°C to +150°C
Typical θ_{JA}	
N Package	52.0°C/W
M Package	70.0°C/W

Note 1: The "Absolute Maximum Ratings" are those values beyond which the safety of the device cannot be guaranteed. The device should not be operated at these limits. The parametric values defined in the Electrical Characteristics tables are not guaranteed at the absolute maximum ratings. The "Recommended Operating Conditions" table will define the conditions for actual device operation.

Recommended Operating Conditions

Symbol	Parameter	Min	Nom	Max	Units
V_{CC}	Supply Voltage	4.5	5	5.5	V
V_{IH}	HIGH Level Input Voltage	2			V
V_{IL}	LOW Level Input Voltage			0.8	V
I_{OH}	HIGH Level Output Current			-15	mA
I_{OL}	LOW Level Output Current			48	mA
t_W	Width of Enable Pulse	HIGH	4.5		ns
		LOW	5.5		
t_{SU}	Data Setup Time (Note 2)	2 \uparrow			ns
t_H	Data Hold Time (Note 2)	3 \uparrow			ns
T_A	Free Air Operating Temperature	0		70	°C

Note 2: The (\uparrow) arrow indicates the positive edge of the Clock is used for reference.

Electrical Characteristics

over recommended operating free air temperature range. All typical values are measured at $V_{CC} = 5V$, $T_A = 25^\circ C$.

Symbol	Parameter	Conditions	Min	Typ	Max	Units
V_{IK}	Input Clamp Voltage	$V_{CC} = 4.5V$, $I_I = -18$ mA			-1.2	V
V_{OH}	HIGH Level Output Voltage	$V_{CC} = 4.5V$, $V_{IL} = \text{Max}$, $I_{OH} = \text{Max}$	2.4	3.3		V
	Output Voltage	$V_{CC} = 4.5V$ to $5.5V$, $I_{OH} = -2$ mA	$V_{CC} - 2$			
V_{OL}	LOW Level Output Voltage	$V_{CC} = 4.5V$, $V_{IH} = 2V$		0.35	0.5	V
	Output Voltage	$I_{OL} = \text{Max}$				
I_I	Input Current @ Max Input Voltage	$V_{CC} = 5.5V$, $V_{IH} = 7V$			0.1	mA
I_{IH}	HIGH Level Input Current	$V_{CC} = 5.5V$, $V_{IH} = 2.7V$			20	μA
I_{IL}	LOW Level Input Current	$V_{CC} = 5.5V$, $V_{IL} = 0.4V$			-0.5	mA
I_O (Note 3)	Output Drive Current	$V_{CC} = 5.5V$, $V_O = 2.25V$	-30		-112	mA
I_{OZH}	OFF-State Output Current, HIGH Level Voltage Applied	$V_{CC} = 5.5V$, $V_{IH} = 2V$, $V_O = 2.7V$			50	μA
I_{OZL}	Off-State Output Current, Low Level Voltage Applied	$V_{CC} = 5.5V$, $V_{IH} = 2V$, $V_O = 0.4V$			-50	μA
I_{CC}	Supply Current	$V_{CC} = 5.5V$	Outputs HIGH	56	93	mA
		Outputs Open	Outputs LOW	55	90	
			Outputs Disabled	65	106	

Note 3: The output conditions have been chosen to produce a current that approximates one half of the true short-circuit output current, I_{OS} .

Switching Characteristics

over recommended operating free air temperature range

Symbol	Parameter	Conditions	From	To	Min	Max	Units
t_{PLH}	Propagation Delay Time LOW-to-HIGH Level Output	$V_{CC} = 4.5V$ to $5.5V$ $R_L = 500\Omega$ $C_L = 50$ pF	Data	Any Q	3	6	ns
t_{PHL}	Propagation Delay Time HIGH-to-LOW Level Output		Data	Any Q	3	6	ns
t_{PLH}	Propagation Delay Time LOW-to-HIGH Level Output		Enable	Any Q	6	11.5	ns
t_{PHL}	Propagation Delay Time HIGH-to-LOW Level Output		Enable	Any Q	4	7.5	ns
t_{pZH}	Output Enable Time to HIGH Level Output		$\overline{\text{Output Control}}$	Any Q	2	6.5	ns
t_{pZL}	Output Enable Time to LOW Level Output		$\overline{\text{Output Control}}$	Any Q	4	9.5	ns
t_{pHZ}	Output Disable Time from HIGH Level Output		$\overline{\text{Output Control}}$	Any Q	2	6.5	ns
t_{pLZ}	Output Disable Time from LOW Level Output		$\overline{\text{Output Control}}$	Any Q	2	7	ns

Physical Dimensions inches (millimeters) unless otherwise noted

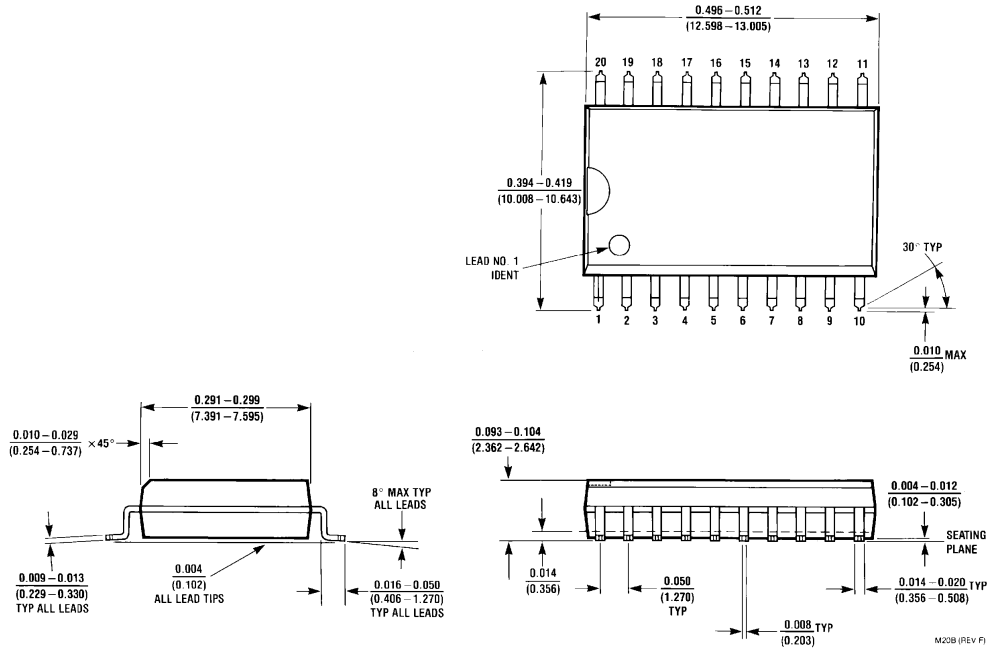

**20-Lead Small Outline Integrated Circuit (SOIC), JEDEC MS-013, 0.300 Wide
Package Number M20B**

Physical Dimensions inches (millimeters) unless otherwise noted (Continued)

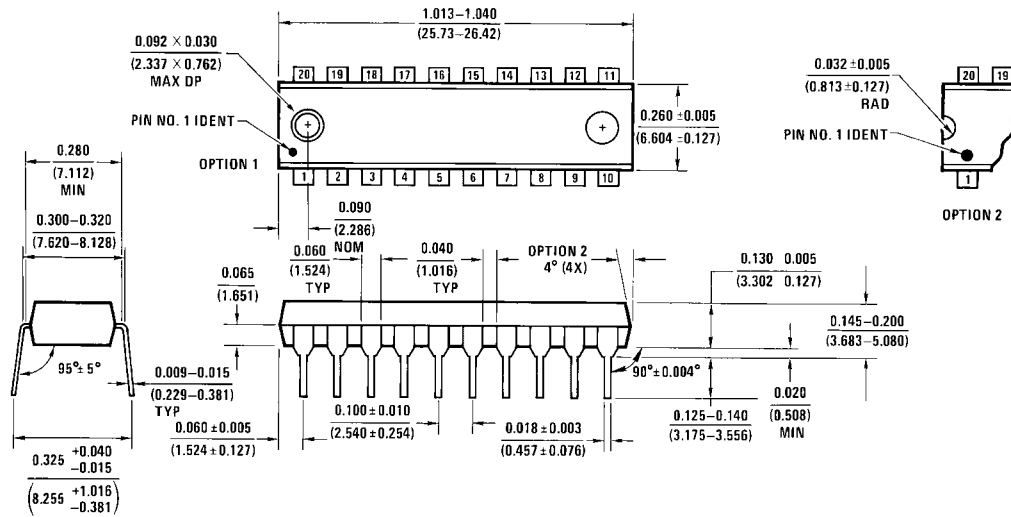

N20A (REV G)

**20-Lead Plastic Dual-In-Line Package (PDIP), JEDEC MS-001, 0.300 Wide
Package Number N20A**

Fairchild does not assume any responsibility for use of any circuitry described, no circuit patent licenses are implied and Fairchild reserves the right at any time without notice to change said circuitry and specifications.

LIFE SUPPORT POLICY

FAIRCHILD'S PRODUCTS ARE NOT AUTHORIZED FOR USE AS CRITICAL COMPONENTS IN LIFE SUPPORT DEVICES OR SYSTEMS WITHOUT THE EXPRESS WRITTEN APPROVAL OF THE PRESIDENT OF FAIRCHILD SEMICONDUCTOR CORPORATION. As used herein:

1. Life support devices or systems are devices or systems which, (a) are intended for surgical implant into the body, or (b) support or sustain life, and (c) whose failure to perform when properly used in accordance with instructions for use provided in the labeling, can be reasonably expected to result in a significant injury to the user.
2. A critical component in any component of a life support device or system whose failure to perform can be reasonably expected to cause the failure of the life support device or system, or to affect its safety or effectiveness.

www.fairchildsemi.com