



Chipsmall Limited consists of a professional team with an average of over 10 year of expertise in the distribution of electronic components. Based in Hongkong, we have already established firm and mutual-benefit business relationships with customers from,Europe,America and south Asia,supplying obsolete and hard-to-find components to meet their specific needs.

With the principle of “Quality Parts,Customers Priority,Honest Operation,and Considerate Service”,our business mainly focus on the distribution of electronic components. Line cards we deal with include Microchip,ALPS,ROHM,Xilinx,Pulse,ON,Everlight and Freescale. Main products comprise IC,Modules,Potentiometer,IC Socket,Relay,Connector.Our parts cover such applications as commercial,industrial, and automotives areas.

We are looking forward to setting up business relationship with you and hope to provide you with the best service and solution. Let us make a better world for our industry!



## Contact us

Tel: +86-755-8981 8866 Fax: +86-755-8427 6832

Email & Skype: info@chipsmall.com Web: www.chipsmall.com

Address: A1208, Overseas Decoration Building, #122 Zhenhua RD., Futian, Shenzhen, China



## DM74AS873 Dual 4-Bit D-Type Transparent Latches with 3-STATE Outputs

### General Description

These dual 4-bit registers feature totem-pole 3-STATE outputs designed specifically for driving highly-capacitive or relatively low-impedance loads. The high-impedance state and increased high-logic-level drive provide these registers with the capability of being connected directly to and driving the bus lines in a bus-organized system without need for interface or pull-up components. They are particularly attractive for implementing buffer registers, I/O ports, bidirectional bus drivers, and working registers.

The eight latches of the DM74AS873 are transparent D-type latches meaning that while the enable (G) is HIGH the Q outputs will follow the data (D) inputs. When the enable is taken LOW the output will be latched at the level of the data that was set up.

A buffered output control input can be used to place the eight outputs in either a normal logic state (HIGH or LOW logic levels) or a high-impedance state. In the high-impedance state the outputs neither load nor drive the bus lines significantly.

The output control does not affect the internal operation of the latches. That is, the old data can be retained or new data can be entered even while the outputs are OFF.

The pinout is arranged to ease printed circuit board layout. All data inputs are on one side of the package while all outputs are on the other side.

### Features

- Switching specifications at 50 pF
- Switching specifications guaranteed over full temperature and  $V_{CC}$  range
- Advanced oxide-isolated, ion-implanted Schottky TTL process
- 3-STATE buffer-type outputs drive bus lines directly
- Space Saving 300 Mil Wide Package
- Bus structured pinout

### Ordering Code:

Order Number	Package Number	Package Description
DM74AS873NT	N24C	24-Lead Plastic Dual-In-Line Package (PDIP), JEDEC MS-001, 0.300" Wide

Devices also available in Tape and Reel. Specify by appending the suffix letter "X" to the ordering code.

### Connection Diagram

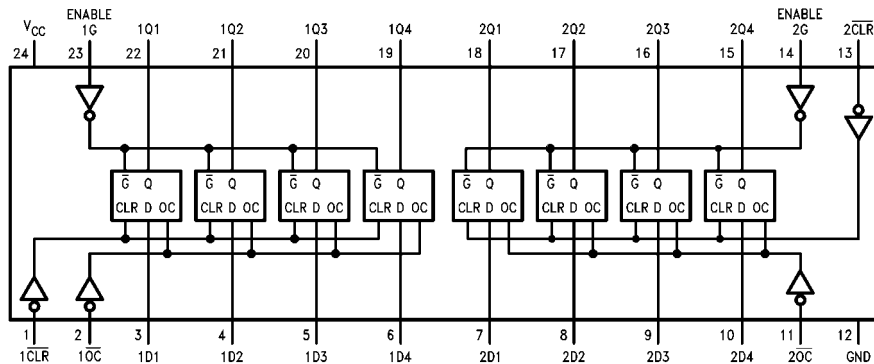

### Function Table

Inputs				Output
CLR	D	EN	OC	Q
X	X	X	H	Z
L	X	X	L	L
H	H	H	L	H
H	L	H	L	L
H	X	L	L	Q <sub>0</sub>

L = LOW State  
 H = HIGH State  
 X = Don't Care  
 Z = High Impedance State  
 Q<sub>0</sub> = Previous Condition of Q

### Logic Diagram

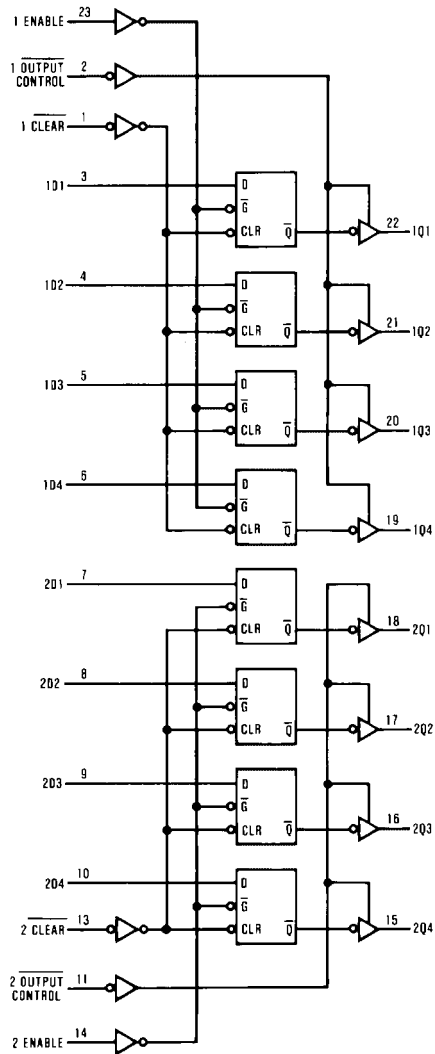

**Absolute Maximum Ratings**(Note 1)

Supply Voltage	7V
Input Voltage	7V
Voltage Applied to Disabled Output	5.5V
Operating Free Air Temperature Range	0°C to +70°C
Storage Temperature Range	-65°C to +150°C
Typical $\theta_{JA}$	
N Package	47.0°C/W

**Note 1:** The "Absolute Maximum Ratings" are those values beyond which the safety of the device cannot be guaranteed. The device should not be operated at these limits. The parametric values defined in the Electrical Characteristics tables are not guaranteed at the absolute maximum ratings. The "Recommended Operating Conditions" table will define the conditions for actual device operation.

**Recommended Operating Conditions**

Symbol	Parameter	Min	Nom	Max	Units
$V_{CC}$	Supply Voltage	4.5	5	5.5	V
$V_{IH}$	HIGH Level Input Voltage	2			V
$V_{IL}$	LOW Level Input Voltage			0.8	V
$I_{OH}$	HIGH Level Output Current			-15	mA
$I_{OL}$	LOW Level Output Current			48	mA
$t_W$	Pulse Width	Enable HIGH	5.5		ns
		Clear LOW	3.5		
$t_{SU}$	Data Setup Time (Note 2)	2↓			ns
$t_H$	Data Hold Time (Note 2)	3↓			ns
$T_A$	Free Air Operating Temperature	0		70	°C

**Note 2:** The (↓) arrow indicates the negative edge of the enable is used for reference.

**Electrical Characteristics**

over recommended operating free air temperature range. All typical values are measured at  $V_{CC} = 5V$ ,  $T_A = 25^\circ C$ .

Symbol	Parameter	Conditions	Min	Typ	Max	Units
$V_{IK}$	Input Clamp Voltage	$V_{CC} = 4.5V$ , $I_I = -18\text{ mA}$			-1.2	V
$V_{OH}$	HIGH Level Output Voltage	$V_{CC} = 4.5V$ , $V_{IL} = \text{Max}$ $I_{OH} = \text{Max}$	2.4	3.3		V
		$I_{OH} = -2\text{ mA}$ , $V_{CC} = 4.5V\text{ to }5.5V$	$V_{CC} - 2$			V
$V_{OL}$	LOW Level Output Voltage	$V_{CC} = 4.5V$ , $V_{IH} = 2V$ $I_{OL} = \text{Max}$		0.35	0.5	V
$I_I$	Input Current at Max Input Voltage	$V_{CC} = 5.5V$ , $V_{IH} = 7V$			0.1	mA
$I_{IH}$	HIGH Level Input Current	$V_{CC} = 5.5V$ , $V_{IH} = 2.7V$			20	$\mu A$
$I_{IL}$	LOW Level Input Current	$V_{CC} = 5.5V$ , $V_{IL} = 0.4V$			-0.5	mA
$I_O$ (Note 3)	Output Drive Current	$V_{CC} = 5.5V$ , $V_O = 2.25V$	-30		-112	mA
$I_{OZH}$	OFF-State Output Current, HIGH Level Voltage Applied	$V_{CC} = 5.5V$ , $V_{IH} = 2V$ $V_O = 2.7V$			50	$\mu A$
$I_{OZL}$	OFF-State Output Current, LOW Level Voltage Applied	$V_{CC} = 5.5V$ , $V_{IH} = 2V$ $V_O = 0.4V$			-50	$\mu A$
$I_{CC}$	Supply Current	$V_{CC} = 5.5V$	Outputs HIGH	68	110	mA
		Outputs Open	Outputs LOW	67	109	mA
			Outputs Disabled	80	129	mA

**Note 3:** The output conditions have been chosen to produce a current that closely approximates one half of the true short circuit current,  $I_{OS}$ .

## Switching Characteristics

over recommended operating free air temperature range. All typical values are measured at  $V_{CC} = 5V$ ,  $T_A = 25^\circ C$ .

Symbol	Parameter	Conditions	From	To	Min	Max	Units
$t_{PLH}$	Propagation Delay Time LOW-to-HIGH Level Output	$V_{CC} = 4.5V$ to $5.5V$ $R_L = 500\Omega$ $C_L = 50$ pF	Data	Any Q	3	6.5	ns
$t_{PHL}$	Propagation Delay Time HIGH-to-LOW Level Output		Data	Any Q	3	6	ns
$t_{PLH}$	Propagation Delay Time LOW-to-HIGH Level Output		Enable	Any Q	6	11.5	ns
$t_{PHL}$	Propagation Delay Time HIGH-to-LOW Level Output		Enable	Any Q	4	7.5	ns
$t_{pZH}$	Output Enable Time to HIGH Level Output		$\overline{\text{Output Control}}$	Any Q	2	6.5	ns
$t_{pZL}$	Output Enable Time to LOW Level Output		$\overline{\text{Output Control}}$	Any Q	4	9.5	ns
$t_{PHZ}$	Output Disable Time from HIGH Level Output		$\overline{\text{Output Control}}$	Any Q	2	6.5	ns
$t_{PLZ}$	Output Disable Time from LOW Level Output		$\overline{\text{Output Control}}$	Any Q	2	7.5	ns
$t_{PHL}$	Propagation Delay Time HIGH-to-LOW Level Output		$\overline{\text{Clear}}$	Any Q	3	8.5	ns

