



Chipsmall Limited consists of a professional team with an average of over 10 year of expertise in the distribution of electronic components. Based in Hongkong, we have already established firm and mutual-benefit business relationships with customers from,Europe,America and south Asia,supplying obsolete and hard-to-find components to meet their specific needs.

With the principle of "Quality Parts,Customers Priority,Honest Operation,and Considerate Service",our business mainly focus on the distribution of electronic components. Line cards we deal with include Microchip,ALPS,ROHM,Xilinx,Pulse,ON,Everlight and Freescale. Main products comprise IC,Modules,Potentiometer,IC Socket,Relay,Connector.Our parts cover such applications as commercial,industrial, and automotives areas.

We are looking forward to setting up business relationship with you and hope to provide you with the best service and solution. Let us make a better world for our industry!



## Contact us

Tel: +86-755-8981 8866 Fax: +86-755-8427 6832

Email & Skype: info@chipsmall.com Web: www.chipsmall.com

Address: A1208, Overseas Decoration Building, #122 Zhenhua RD., Futian, Shenzhen, China



## DM74LS164 8-Bit Serial In/Parallel Out Shift Register

### General Description

These 8-bit shift registers feature gated serial inputs and an asynchronous clear. A low logic level at either input inhibits entry of the new data, and resets the first flip-flop to the low level at the next clock pulse, thus providing complete control over incoming data. A high logic level on either input enables the other input, which will then determine the state of the first flip-flop. Data at the serial inputs may be changed while the clock is HIGH or LOW, but only information meeting the setup and hold time requirements will be entered. Clocking occurs on the LOW-to-HIGH level transition of the clock input. All inputs are diode-clamped to minimize transmission-line effects.

### Features

- Gated (enable/disable) serial inputs
- Fully buffered clock and serial inputs
- Asynchronous clear
- Typical clock frequency 36 MHz
- Typical power dissipation 80 mW

### Ordering Code:

Order Number	Package Number	Package Description
DM74LS164M	M14A	14-Lead Small Outline Integrated Circuit (SOIC), JEDEC MS-120, 0.150 Narrow
DM74LS164N	N14A	14-Lead Plastic Dual-In-Line Package (PDIP), JEDEC MS-001, 0.300 Wide

Devices also available in Tape and Reel. Specify by appending the suffix letter "X" to the ordering code.

### Connection Diagram

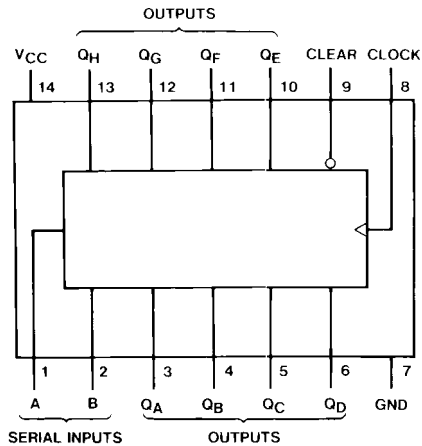

### Function Table

Inputs				Outputs			
Clear	Clock	A	B	QA	QB	...	QH
L	X	X	X	L	L	...	L
H	L	X	X	QA0	QB0	...	QH0
H	↑	H	H	H	QA <sub>n</sub>	...	Q <sub>Gn</sub>
H	↑	L	X	L	QA <sub>n</sub>	...	Q <sub>Gn</sub>
H	↑	X	L	L	QA <sub>n</sub>	...	Q <sub>Gn</sub>

H = HIGH Level (steady state)

L = LOW Level (steady state)

X = Don't Care (any input, including transitions)

↑ = Transition from LOW-to-HIGH level

QA<sub>0</sub>, QB<sub>0</sub>, QH<sub>0</sub> = The level of QA, QB, or QH, respectively, before the indicated steady-state input conditions were established.

QA<sub>n</sub>, Q<sub>Gn</sub> = The level of QA or QG before the most recent ↑ transition of the clock; indicates a one-bit shift.

### Logic Diagram

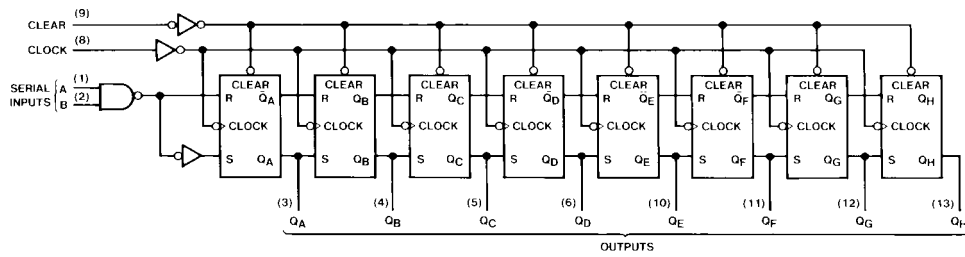

### Timing Diagram

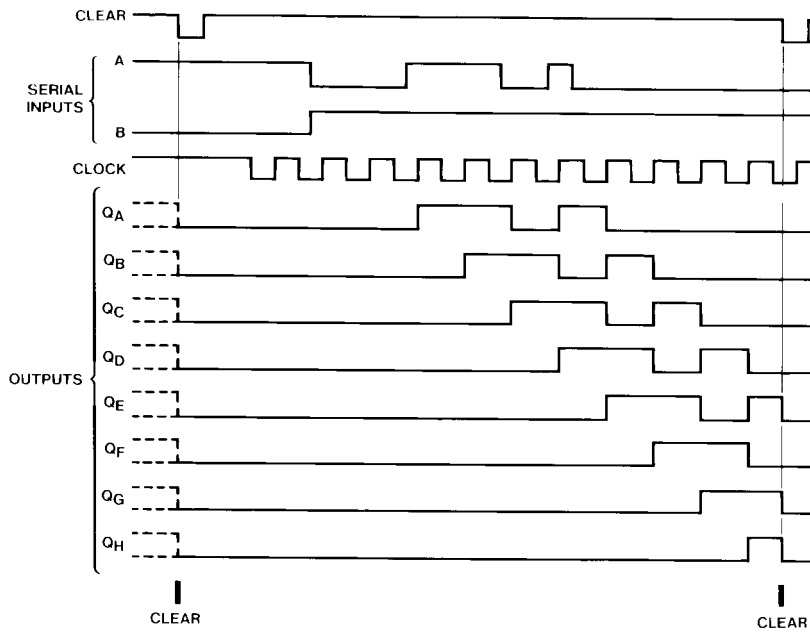

**Absolute Maximum Ratings**(Note 1)

Supply Voltage	7V
Input Voltage	7V
Operating Free Air Temperature Range	0°C to +70°C
Storage Temperature Range	-65°C to +150°C

**Note 1:** The "Absolute Maximum Ratings" are those values beyond which the safety of the device cannot be guaranteed. The device should not be operated at these limits. The parametric values defined in the Electrical Characteristics tables are not guaranteed at the absolute maximum ratings. The "Recommended Operating Conditions" tables will define the conditions for actual device operation.

**Recommended Operating Conditions**

Symbol	Parameter	Min	Nom	Max	Units
$V_{CC}$	Supply Voltage	4.75	5	5.25	V
$V_{IH}$	HIGH Level Input Voltage	2			V
$V_{IL}$	LOW Level Input Voltage			0.8	V
$I_{OH}$	HIGH Level Output Current			-0.4	mA
$I_{OL}$	LOW Level Output Current			8	mA
$f_{CLK}$	Clock Frequency (Note 2)	0		25	MHz
$t_W$	Pulse Width (Note 2)	Clock	20		ns
		Clear	20		
$t_{SU}$	Data Setup Time (Note 2)	17			ns
$t_H$	Data Hold Time (Note 2)	5			ns
$t_{REL}$	Clear Release Time (Note 2)	30			ns
$T_A$	Free Air Operating Temperature	0		70	°C

**Note 2:**  $T_A = 25^\circ\text{C}$  and  $V_{CC} = 5\text{V}$ .

**Electrical Characteristics**

over recommended operating free air temperature range (unless otherwise noted)

Symbol	Parameter	Conditions	Min	Typ (Note 3)	Max	Units
$V_I$	Input Clamp Voltage	$V_{CC} = \text{Min}, I_I = -18\text{ mA}$			-1.5	V
$V_{OH}$	HIGH Level Output Voltage	$V_{CC} = \text{Min}, I_{OH} = \text{Max}$ $V_{IL} = \text{Max}, V_{IH} = \text{Min}$	2.7	3.4		V
$V_{OL}$	LOW Level Output Voltage	$V_{CC} = \text{Min}, I_{OL} = \text{Max}$ $V_{IL} = \text{Max}, V_{IH} = \text{Min}$		0.35	0.5	V
		$I_{OL} = 4\text{ mA}, V_{CC} = \text{Min}$		0.25	0.4	
$I_I$	Input Current @ Max Input Voltage	$V_{CC} = \text{Max}, V_I = 7\text{V}$			0.1	mA
$I_{IH}$	HIGH Level Input Current	$V_{CC} = \text{Max}, V_I = 2.7\text{V}$			20	$\mu\text{A}$
$I_{IL}$	LOW Level Input Current	$V_{CC} = \text{Max}, V_I = 0.4\text{V}$			-0.4	mA
$I_{OS}$	Short Circuit Output Current	$V_{CC} = \text{Max}$ (Note 4)	-20		-100	mA
$I_{CC}$	Supply Current	$V_{CC} = \text{Max}$ (Note 5)		16	27	mA

**Note 3:** All typicals are at  $V_{CC} = 5\text{V}$ ,  $T_A = 25^\circ\text{C}$ .

**Note 4:** Not more than one output should be shorted at a time, and the duration should not exceed one second.

**Note 5:**  $I_{CC}$  is measured with all outputs OPEN, the SERIAL input grounded, the CLOCK input at 2.4V, and a momentary ground, then 4.5V, applied to the CLEAR input.

**Switching Characteristics**

at  $V_{CC} = 5\text{V}$  and  $T_A = 25^\circ\text{C}$

Symbol	Parameter	From (Input) To (Output)	$R_L = 2\text{ k}\Omega$				Units
			$C_L = 15\text{ pF}$		$C_L = 50\text{ pF}$		
			Min	Max	Min	Max	
$f_{MAX}$	Maximum Clock Frequency		25				MHz
$t_{PLH}$	Propagation Delay Time LOW-to-HIGH Level Output	Clock to Output		27		30	ns
$t_{PHL}$	Propagation Delay Time HIGH-to-LOW Level Output	Clock to Output		32		40	ns
$t_{PHL}$	Propagation Delay Time HIGH-to-LOW Level Output	Clear to Output		36		45	ns

**Physical Dimensions** inches (millimeters) unless otherwise noted

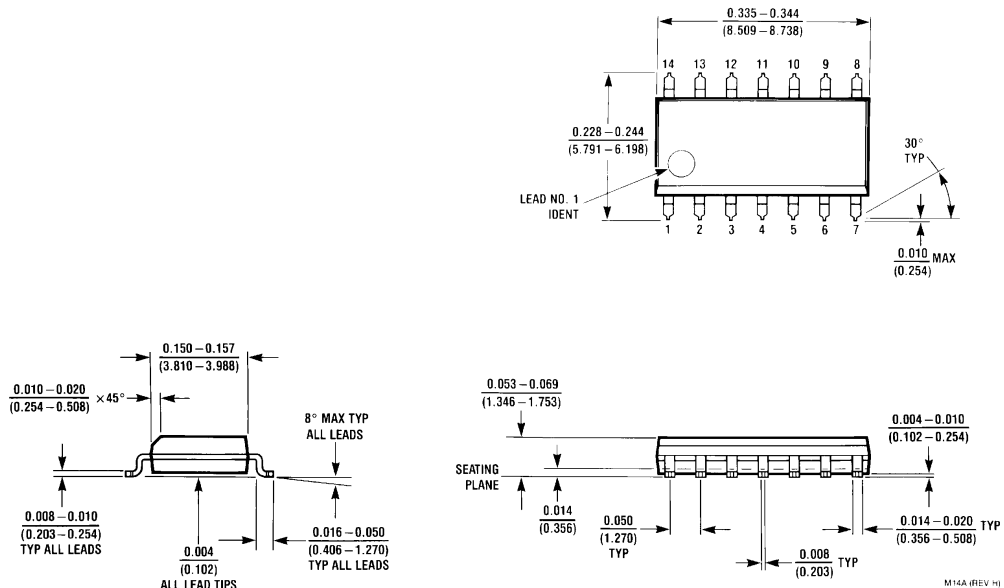

**14-Lead Small Outline Integrated Circuit (SOIC), JEDEC MS-120, 0.150 Narrow  
Package Number M14A**

**Physical Dimensions** inches (millimeters) unless otherwise noted (Continued)

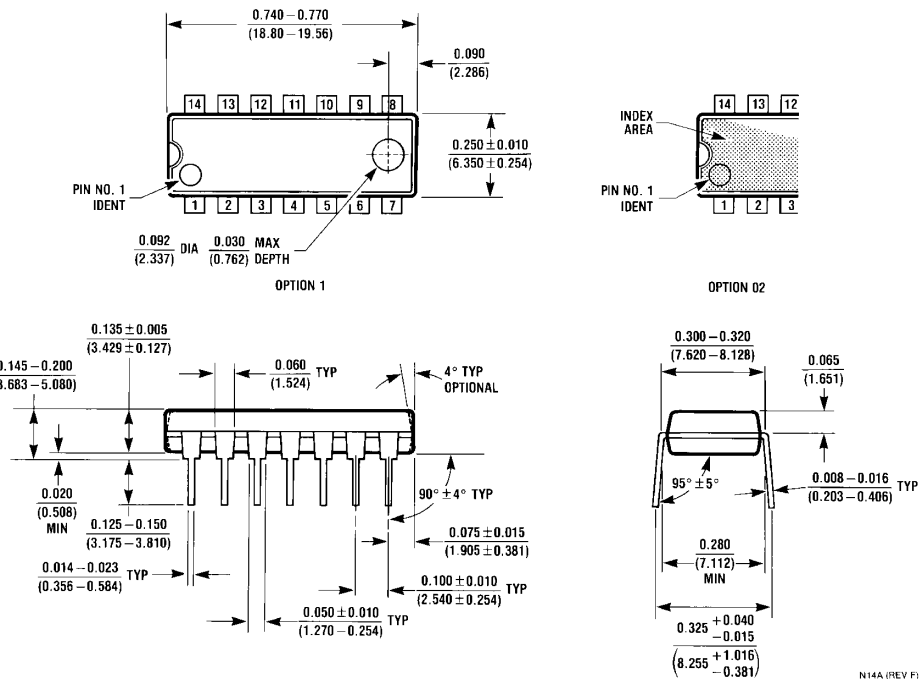

**14-Lead Plastic Dual-In-Line Package (PDIP), JEDEC MS-001, 0.300 Wide Package Number N14A**

Fairchild does not assume any responsibility for use of any circuitry described, no circuit patent licenses are implied and Fairchild reserves the right at any time without notice to change said circuitry and specifications.

**LIFE SUPPORT POLICY**

FAIRCHILD'S PRODUCTS ARE NOT AUTHORIZED FOR USE AS CRITICAL COMPONENTS IN LIFE SUPPORT DEVICES OR SYSTEMS WITHOUT THE EXPRESS WRITTEN APPROVAL OF THE PRESIDENT OF FAIRCHILD SEMICONDUCTOR CORPORATION. As used herein:

1. Life support devices or systems are devices or systems which, (a) are intended for surgical implant into the body, or (b) support or sustain life, and (c) whose failure to perform when properly used in accordance with instructions for use provided in the labeling, can be reasonably expected to result in a significant injury to the user.
2. A critical component in any component of a life support device or system whose failure to perform can be reasonably expected to cause the failure of the life support device or system, or to affect its safety or effectiveness.

[www.fairchildsemi.com](http://www.fairchildsemi.com)