



Chipsmall Limited consists of a professional team with an average of over 10 year of expertise in the distribution of electronic components. Based in Hongkong, we have already established firm and mutual-benefit business relationships with customers from,Europe,America and south Asia,supplying obsolete and hard-to-find components to meet their specific needs.

With the principle of “Quality Parts,Customers Priority,Honest Operation,and Considerate Service”,our business mainly focus on the distribution of electronic components. Line cards we deal with include Microchip,ALPS,ROHM,Xilinx,Pulse,ON,Everlight and Freescale. Main products comprise IC,Modules,Potentiometer,IC Socket,Relay,Connector.Our parts cover such applications as commercial,industrial, and automotives areas.

We are looking forward to setting up business relationship with you and hope to provide you with the best service and solution. Let us make a better world for our industry!



Contact us

Tel: +86-755-8981 8866 Fax: +86-755-8427 6832

Email & Skype: info@chipsmall.com Web: www.chipsmall.com

Address: A1208, Overseas Decoration Building, #122 Zhenhua RD., Futian, Shenzhen, China



DM74S182 Look-Ahead Carry Generator

General Description

These circuits are high-speed, look-ahead carry generators, capable of anticipating a carry across four binary adders or groups of adders. They are cascadable to perform full look-ahead across n-bit adders. Carry, generate-carry, and propagate-carry functions are provided as shown in the pin designation table.

When used in conjunction with the 181 arithmetic logic unit, these generators provide high-speed carry look-ahead capability for any word length. Each DM74S182 generates the look-ahead (anticipated carry) across a group of four ALU's and, in addition, other carry look-ahead circuits may be employed to anticipate carry across sections of four look-ahead packages up to n-bits. The method of cascading circuits to perform multi-level look-ahead is illustrated under typical application data.

Carry input and output of the ALU's are in their true form, and the carry propagate (P) and carry generate (G) are in negated form; therefore, the carry functions (inputs, out-

puts, generate, and propagate) of the look-ahead generators are implemented in the compatible forms for direct connection to the ALU. Reinterpretations of carry functions, as explained on the 181 data sheet are also applicable to and compatible with the look-ahead generator. Positive logic equations for the DM74S182 are:

$$C_{n+x} = \bar{G}0 + \bar{P}0 C_n$$

$$C_{n+y} = \bar{G}1 + \bar{P}1 \bar{G}0 + \bar{P}1 \bar{P}0 C_n$$

$$C_{n+z} = \bar{G}2 + \bar{P}2 \bar{G}1 + \bar{P}2 \bar{P}1 \bar{G}0 + \bar{P}2 \bar{P}1 \bar{P}0 C_n$$

$$\bar{G} = \bar{G}3 (\bar{P}3 + \bar{G}2) (\bar{P}3 + \bar{P}2 + \bar{G}1) (\bar{P}3 + \bar{P}2 + \bar{P}1 + \bar{G}0)$$

$$\bar{P} = \bar{P}3 \bar{P}2 \bar{P}1 \bar{P}0$$

Features

- Typical propagation delay time 7 ns
- Typical power dissipation 260 mW

Ordering Code:

Order Number	Package Number	Package Description
DM74S182N	N16E	16-Lead Plastic Dual-In-Line Package (PDIP), JEDEC MS-001, 0.300 Wide

Connection Diagram

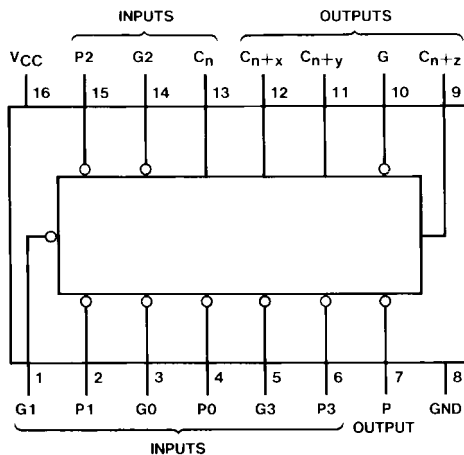

Pin Designations

Designation	Pin Nos.	Function
G0, G1, G2, G3	3, 1, 14, 5	Active LOW Carry Generate Inputs
P0, P1, P2, P3	4, 2, 15, 6	Active LOW Carry Propagate Inputs
C _n	13	Carry Input
C _{n+x} , C _{n+y} , C _{n+z}	12, 11, 9	Carry Outputs
G	10	Active LOW Carry Generate Output
P	7	Active LOW Carry Propagate Output
V _{CC}	16	Supply Voltage
GND	8	Ground

Logic Diagram

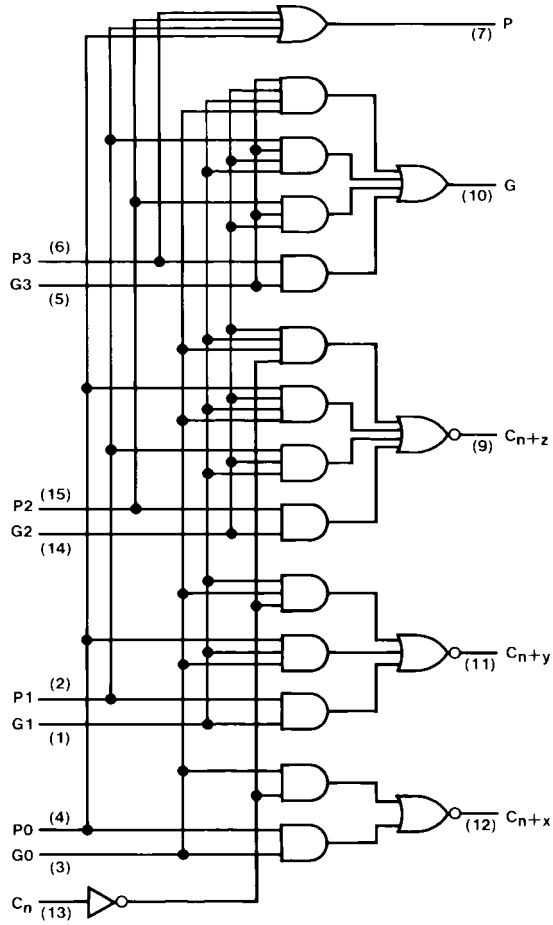

V_{CC} = PIN 16
 GND = PIN 8

Typical Application

64-Bit ALU, Full-Carry Look Ahead in Three Levels

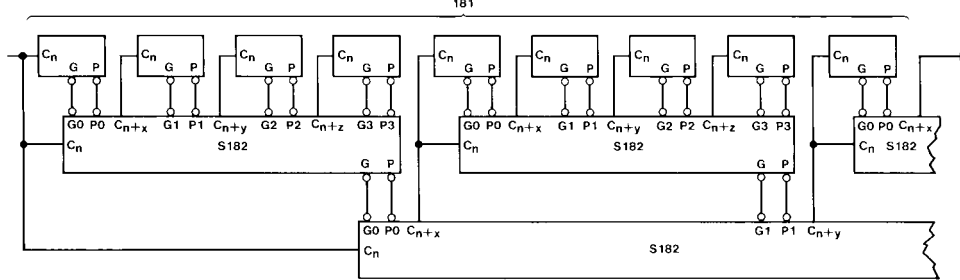

A and B inputs, and F outputs of 181 are not shown.

Absolute Maximum Ratings(Note 1)

Supply Voltage	7V
Input Voltage	5.5V
Operating Free Air Temperature Range	0°C to +70°C
Storage Temperature Range	-65°C to +150°C

Note 1: The "Absolute Maximum Ratings" are those values beyond which the safety of the device cannot be guaranteed. The device should not be operated at these limits. The parametric values defined in the Electrical Characteristics tables are not guaranteed at the absolute maximum ratings. The "Recommended Operating Conditions" table will define the conditions for actual device operation.

Recommended Operating Conditions

Symbol	Parameter	Min	Nom	Max	Units
V _{CC}	Supply Voltage	4.75	5	5.25	V
V _{IH}	HIGH Level Input Voltage	2			V
V _{IL}	LOW Level Input Voltage			0.8	V
I _{OH}	HIGH Level Output Current			-1	mA
I _{OL}	LOW Level Output Current			20	mA
T _A	Free Air Operating Temperature	0		70	°C

Electrical Characteristics

over recommended operating free air temperature (unless otherwise noted)

Symbol	Parameter	Conditions	Min	Typ (Note 2)	Max	Units
V _I	Input Clamp Voltage	V _{CC} = Min, I _I = -18 mA			-1.2	V
V _{OH}	HIGH Level Output Voltage	V _{CC} = Min, I _{OH} = Max V _{IL} = Max, V _{IH} = Min	2.7	3.4		V
V _{OL}	LOW Level Output Voltage	V _{CC} = Min, I _{OL} = Max V _{IH} = Min, V _{IL} = Max			0.5	V
I _I	Input Current @ Max Input Voltage	V _{CC} = Max, V _I = 5.5V			1	mA
I _{IH}	HIGH Level Input Current	V _{CC} = Max V _I = 2.7V	P0, P1 or G3		200	μA
			P3		100	
			P2		150	
			C _n		50	
			G0, G2		350	
			G1		400	
I _{IL}	LOW Level Input Current	V _{CC} = Max V _I = 0.5V	P0, P1 or G3		-8	mA
			P3		-4	
			P2		-6	
			C _n		-2	
			G0, G2		-14	
			G1		-16	
I _{OS}	Short Circuit Output Current	V _{CC} = Max (Note 3)	-40		-100	mA
I _{CCH}	Supply Current with Outputs HIGH	V _{CC} = Max (Note 4)		39	55	mA
I _{CCL}	Supply Currents with Outputs LOW	V _{CC} = Max (Note 5)		69	109	mA

Note 2: All typicals are at V_{CC} = 5V, T_A = 25°C.

Note 3: Not more than one output should be shorted at a time, and the duration should not exceed one second.

Note 4: I_{CCH} is measured with all outputs OPEN, inputs P3 and G3 at 4.5V, and all other inputs grounded.

Note 5: I_{CCL} is measured with all outputs OPEN, inputs G0, G1, and G2 at 4.5V, and all other inputs grounded.

Switching Characteristics

at $V_{CC} = 5V$ and $T_A = 25^\circ C$

Symbol	Parameter	From (Input) To (Output)	$R_L = 280\Omega$				Units
			$C_L = 15\text{ pF}$		$C_L = 50\text{ pF}$		
			Min	Max	Min	Min	
t_{PLH}	Propagation Delay Time LOW-to-HIGH Level Output	GN or PN to $C_{n+x, y, z}$		7		10	ns
t_{PHL}	Propagation Delay Time HIGH-to-LOW Level Output	GN or PN to $C_{n+x, y, z}$		7		11	ns
t_{PLH}	Propagation Delay Time LOW-to-HIGH Level Output	GN or PN to G		7.5		11	ns
t_{PHL}	Propagation Delay Time HIGH-to-LOW Level Output	GN or PN to G		10.5		14	ns
t_{PLH}	Propagation Delay Time LOW-to-HIGH Level Output	PN to P		6.5		10	ns
t_{PHL}	Propagation Delay Time HIGH-to-LOW Level Output	PN to P		10		14	ns
t_{PLH}	Propagation Delay Time LOW-to-HIGH Level Output	C_n to to $C_{n+x, y, z}$		10		13	ns
t_{PHL}	Propagation Delay Time HIGH-to-LOW Level Output	C_n to to $C_{n+x, y, z}$		10.5		14	ns

Physical Dimensions inches (millimeters) unless otherwise noted

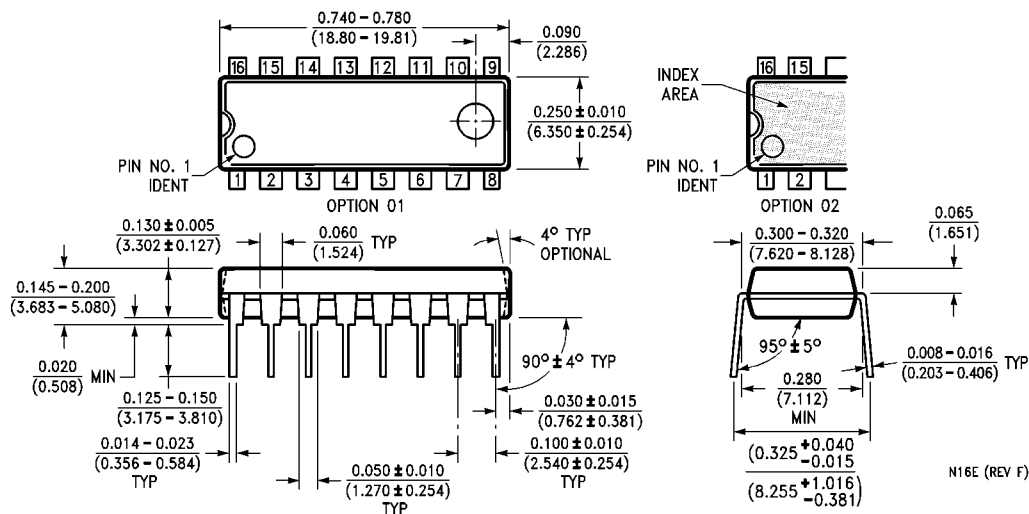

**16-Lead Plastic Dual-In-Line Package (PDIP), JEDEC MS-001, 0.300 Wide
Package Number N16E**

Fairchild does not assume any responsibility for use of any circuitry described, no circuit patent licenses are implied and Fairchild reserves the right at any time without notice to change said circuitry and specifications.

LIFE SUPPORT POLICY

FAIRCHILD'S PRODUCTS ARE NOT AUTHORIZED FOR USE AS CRITICAL COMPONENTS IN LIFE SUPPORT DEVICES OR SYSTEMS WITHOUT THE EXPRESS WRITTEN APPROVAL OF THE PRESIDENT OF FAIRCHILD SEMICONDUCTOR CORPORATION. As used herein:

1. Life support devices or systems are devices or systems which, (a) are intended for surgical implant into the body, or (b) support or sustain life, and (c) whose failure to perform when properly used in accordance with instructions for use provided in the labeling, can be reasonably expected to result in a significant injury to the user.
2. A critical component in any component of a life support device or system whose failure to perform can be reasonably expected to cause the failure of the life support device or system, or to affect its safety or effectiveness.

www.fairchildsemi.com