



Chipsmall Limited consists of a professional team with an average of over 10 year of expertise in the distribution of electronic components. Based in Hongkong, we have already established firm and mutual-benefit business relationships with customers from,Europe,America and south Asia,supplying obsolete and hard-to-find components to meet their specific needs.

With the principle of “Quality Parts,Customers Priority,Honest Operation,and Considerate Service”,our business mainly focus on the distribution of electronic components. Line cards we deal with include Microchip,ALPS,ROHM,Xilinx,Pulse,ON,Everlight and Freescale. Main products comprise IC,Modules,Potentiometer,IC Socket,Relay,Connector.Our parts cover such applications as commercial,industrial, and automotives areas.

We are looking forward to setting up business relationship with you and hope to provide you with the best service and solution. Let us make a better world for our industry!



## Contact us

Tel: +86-755-8981 8866 Fax: +86-755-8427 6832

Email & Skype: info@chipsmall.com Web: www.chipsmall.com

Address: A1208, Overseas Decoration Building, #122 Zhenhua RD., Futian, Shenzhen, China



## DM74S283 4-Bit Binary Adder with Fast Carry

### General Description

These full adders perform the addition of two 4-bit binary numbers. The sum ( $\Sigma$ ) outputs are provided for each bit and the resultant carry (C4) is obtained from the fourth bit. These adders feature full internal look ahead across all four bits. This provides the system designer with partial look-ahead performance at the economy and reduced package count of a ripple-carry implementation.

The adder logic, including the carry, is implemented in its true form meaning that the end-around carry can be accomplished without the need for logic or level inversion.

### Features

- Full-carry look-ahead across the four bits
- Systems achieve partial look-ahead performance with the economy of ripple carry
- Typical add times
  - Two 8-bit words 15 ns
  - Two 16-bit words 30 ns
- Typical power dissipation 510 mW

### Ordering Code:

Order Number	Package Number	Package Description
DM74S283N	N16E	16-Lead Plastic Dual-In-Line Package (PDIP), JEDEC MS-001, 0.300 Wide

### Connection Diagram

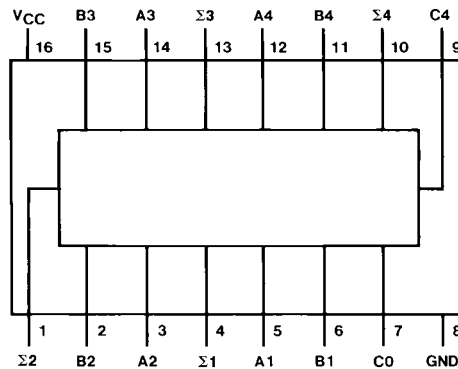



**Absolute Maximum Ratings**(Note 1)

Supply Voltage	7V
Input Voltage	5.5V
Operating Free Air Temperature Range	0°C to +70°C
Storage Temperature Range	-65°C to +150°C

**Note 1:** The "Absolute Maximum Ratings" are those values beyond which the safety of the device cannot be guaranteed. The device should not be operated at these limits. The parametric values defined in the Electrical Characteristics tables are not guaranteed at the absolute maximum ratings. The "Recommended Operating Conditions" table will define the conditions for actual device operation.

**Recommended Operating Conditions**

Symbol	Parameter	Min	Nom	Max	Units
V <sub>CC</sub>	Supply Voltage	4.75	5	5.25	V
V <sub>IH</sub>	HIGH Level Input Voltage	2			V
V <sub>IL</sub>	LOW Level Input Voltage			0.8	V
I <sub>OH</sub>	HIGH Level Output Current (Output C4)			-0.5	mA
	HIGH Level Output Current (Other Outputs)			-1	
I <sub>OL</sub>	LOW Level Output Current (Output C4)			10	mA
	LOW Level Output Current (Other Outputs)			20	
T <sub>A</sub>	Free Air Operating Temperature	0		70	°C

**Electrical Characteristics**

over recommended operating free air temperature (unless otherwise noted)

Symbol	Parameter	Conditions	Min	Typ (Note 2)	Max	Units
V <sub>I</sub>	Input Clamp Voltage	V <sub>CC</sub> = Min, I <sub>I</sub> = -18 mA			-1.2	V
V <sub>OH</sub>	HIGH Level Output Voltage	V <sub>CC</sub> = Min, I <sub>OH</sub> = Max V <sub>IL</sub> = Max, V <sub>IH</sub> = Min	2.7	3.4		V
V <sub>OL</sub>	LOW Level Output Voltage	V <sub>CC</sub> = Min, I <sub>OL</sub> = Max V <sub>IH</sub> = Min, V <sub>IL</sub> = Max			0.5	V
I <sub>I</sub>	Input Current @ Max Input Voltage	V <sub>CC</sub> = Max, V <sub>I</sub> = 5.5V			1	mA
I <sub>IH</sub>	HIGH Level Input Current	V <sub>CC</sub> = Max, V <sub>I</sub> = 2.7V			50	μA
I <sub>IL</sub>	LOW Level Input Current	V <sub>CC</sub> = Max, V <sub>I</sub> = 0.5V			-2	mA
I <sub>OS</sub>	Short Circuit Output Current	V <sub>CC</sub> = Max (Note 3)	C4 Output	-20	-100	mA
			Other Outputs	-40	-100	
I <sub>CC1</sub>	Supply Current	V <sub>CC</sub> = Max (Note 4)		80	120	mA
I <sub>CC2</sub>	Supply Current	V <sub>CC</sub> = Max (Note 5)		95	160	mA

**Note 2:** All typicals are at V<sub>CC</sub> = 5V, T<sub>A</sub> = 25°C.

**Note 3:** Not more than one output should be shorted at a time, and the duration should not exceed one second.

**Note 4:** I<sub>CC1</sub> is measured with all outputs OPEN, all B inputs LOW and all other inputs at 4.5V.

**Note 5:** I<sub>CC2</sub> is measured with all outputs OPEN and all inputs at 4.5V.

## Switching Characteristics

at  $V_{CC} = 5V$  and  $T_A = 25^\circ C$

Symbol	Parameter	From (Input) To (Output)	$R_L = 280\Omega$				Units
			$C_L = 15\text{ pF}$		$C_L = 50\text{ pF}$		
			Min	Max	Min	Max	
$t_{PLH}$	Propagation Delay Time LOW-to-HIGH Level Output	C0 to $\Sigma 1$ or $\Sigma 2$		18		20	ns
$t_{PHL}$	Propagation Delay Time HIGH-to-LOW Level Output	C0 to $\Sigma 1$ or $\Sigma 2$		18		20	ns
$t_{PLH}$	Propagation Delay Time LOW-to-HIGH Level Output	C0 to $\Sigma 3$		18		20	ns
$t_{PHL}$	Propagation Delay Time HIGH-to-LOW Level Output	C0 to $\Sigma 3$		18		20	ns
$t_{PLH}$	Propagation Delay Time LOW-to-HIGH Level Output	C0 to $\Sigma 4$		18		20	ns
$t_{PHL}$	Propagation Delay Time HIGH-to-LOW Level Output	C0 to $\Sigma 4$		18		20	ns
$t_{PLH}$	Propagation Delay Time LOW-to-HIGH Level Output	$A_i, B_i$ to $S_i$		18		20	ns
$t_{PHL}$	Propagation Delay Time HIGH-to-LOW Level Output	$A_i, B_i$ to $S_i$		18		20	ns
$t_{PLH}$	Propagation Delay Time LOW-to-HIGH Level Output (Note 6)	C0 to $\Sigma 4$		11		15	ns
$t_{PHL}$	Propagation Delay Time HIGH-to-LOW Level Output (Note 6)	C0 to $\Sigma 4$		11		15	ns
$t_{PLH}$	Propagation Delay Time LOW-to-HIGH Level Output (Note 6)	$A_i, B_i$ to C4		12		16	ns
$t_{PHL}$	Propagation Delay Time HIGH-to-LOW Level Output (Note 6)	$A_i, B_i$ to C4		12		16	ns

Note 6:  $R_L = 560\Omega$ .

**Physical Dimensions** inches (millimeters) unless otherwise noted

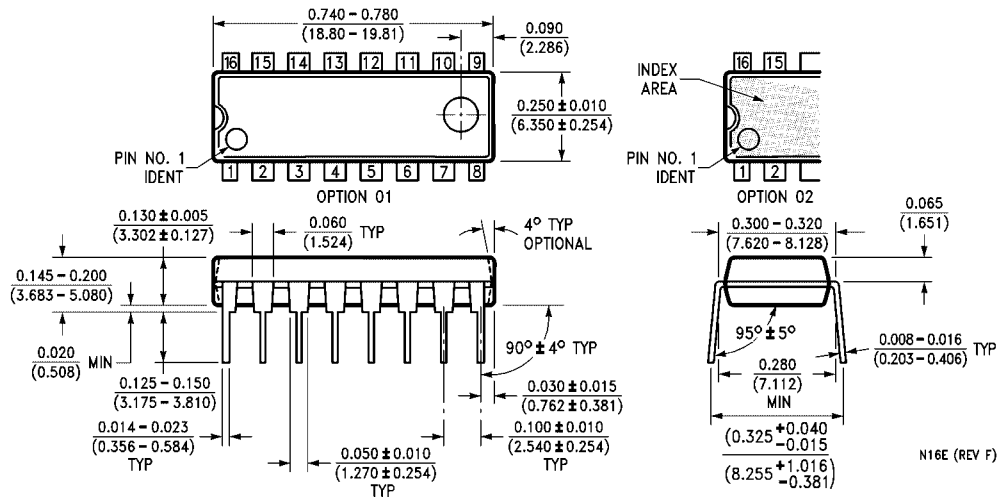

**16-Lead Plastic Dual-In-Line Package (PDIP), JEDEC MS-001, 0.300 Wide Package Number N16E**

Fairchild does not assume any responsibility for use of any circuitry described, no circuit patent licenses are implied and Fairchild reserves the right at any time without notice to change said circuitry and specifications.

**LIFE SUPPORT POLICY**

FAIRCHILD'S PRODUCTS ARE NOT AUTHORIZED FOR USE AS CRITICAL COMPONENTS IN LIFE SUPPORT DEVICES OR SYSTEMS WITHOUT THE EXPRESS WRITTEN APPROVAL OF THE PRESIDENT OF FAIRCHILD SEMICONDUCTOR CORPORATION. As used herein:

1. Life support devices or systems are devices or systems which, (a) are intended for surgical implant into the body, or (b) support or sustain life, and (c) whose failure to perform when properly used in accordance with instructions for use provided in the labeling, can be reasonably expected to result in a significant injury to the user.
2. A critical component in any component of a life support device or system whose failure to perform can be reasonably expected to cause the failure of the life support device or system, or to affect its safety or effectiveness.

[www.fairchildsemi.com](http://www.fairchildsemi.com)