



Chipsmall Limited consists of a professional team with an average of over 10 year of expertise in the distribution of electronic components. Based in Hongkong, we have already established firm and mutual-benefit business relationships with customers from,Europe,America and south Asia,supplying obsolete and hard-to-find components to meet their specific needs.

With the principle of “Quality Parts,Customers Priority,Honest Operation,and Considerate Service”,our business mainly focus on the distribution of electronic components. Line cards we deal with include Microchip,ALPS,ROHM,Xilinx,Pulse,ON,Everlight and Freescale. Main products comprise IC,Modules,Potentiometer,IC Socket,Relay,Connector.Our parts cover such applications as commercial,industrial, and automotives areas.

We are looking forward to setting up business relationship with you and hope to provide you with the best service and solution. Let us make a better world for our industry!



Contact us

Tel: +86-755-8981 8866 Fax: +86-755-8427 6832

Email & Skype: info@chipsmall.com Web: www.chipsmall.com

Address: A1208, Overseas Decoration Building, #122 Zhenhua RD., Futian, Shenzhen, China



DM74S74

Dual Positive-Edge-Triggered D Flip-Flops with Preset, Clear, and Complementary Outputs

General Description

This device contains two independent positive-edge-triggered D flip-flops with complementary outputs. The information on the D input is accepted by the flip-flops on the positive going edge of the clock pulse. The triggering occurs at a voltage level and is not directly related to the transition time of the rising edge of the clock. The data on the D input may be changed while the clock is LOW or HIGH without affecting the outputs as long as setup and hold times are not violated. A low logic level on the preset or clear inputs will set or reset the outputs regardless of the logic levels of the other inputs.

Ordering Code:

Order Number	Package Number	Package Description
DM74S74M	M14A	14-Lead Small Outline Integrated Circuit (SOIC), JEDEC MS-120, 0.150 Narrow
DM74S74N	N14A	14-Lead Plastic Dual-In-Line Package (PDIP), JEDEC MS-001, 0.300 Wide

Devices also available in Tape and Reel. Specify by appending the suffix letter "X" to the ordering code.

Connection Diagram

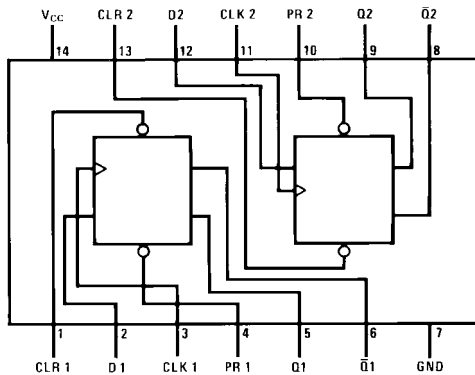

Function Table

Inputs				Outputs	
PR	CLR	CLK	D	Q	\bar{Q}
L	H	X	X	H	L
H	L	X	X	L	H
L	L	X	X	H*	H*
H	H	↑	H	H	L
H	H	↑	L	L	H
H	H	L	X	Q ₀	\bar{Q}_0

H = HIGH Logic Level

X = Either LOW or HIGH Logic Level

L = LOW Logic Level

↑ = Positive-going Transition

* = This configuration is nonstable; that is, it will not persist when either the preset and/or clear inputs return to its inactive (HIGH) level.

Q₀ = The output logic level of Q before the indicated input conditions were established.

Absolute Maximum Ratings(Note 1)

Supply Voltage	7V
Input Voltage	5.5V
Operating Free Air Temperature Range	0°C to +70°C
Storage Temperature Range	-65°C to +150°C

Note 1: The "Absolute Maximum Ratings" are those values beyond which the safety of the device cannot be guaranteed. The device should not be operated at these limits. The parametric values defined in the Electrical Characteristics tables are not guaranteed at the absolute maximum ratings. The "Recommended Operating Conditions" table will define the conditions for actual device operation.

Recommended Operating Conditions

Symbol	Parameter	Min	Nom	Max	Units
V_{CC}	Supply Voltage	4.75	5	5.25	V
V_{IH}	HIGH Level Input Voltage	2			V
V_{IL}	LOW Level Input Voltage			0.8	V
I_{OH}	HIGH Level Output Current			-1	mA
I_{OL}	LOW Level Output Current			20	mA
f_{CLK}	Clock Frequency (Note 2)	0	110	75	MHz
f_{CLK}	Clock Frequency (Note 3)	0	95	65	MHz
t_w	Pulse Width (Note 2)	Clock HIGH	6		ns
		Clock LOW	7.3		
		Clear LOW	7		
		Preset LOW	7		
t_w	Pulse Width (Note 3)	Clock HIGH	8		ns
		Clock LOW	9		
		Clear LOW	9		
		Preset LOW	9		
t_{SU}	Setup Time (Note 2)(Note 4)	3 \uparrow			ns
t_{SU}	Setup Time (Note 3)(Note 4)	3 \uparrow			ns
t_H	Input Hold Time (Note 2)(Note 4)	2 \uparrow			ns
t_H	Input Hold Time (Note 3)(Note 4)	2 \uparrow			ns
T_A	Free Air Operating Temperature	0		70	°C

Note 2: $C_L = 15$ pF, $R_L = 280\Omega$, $T_A = 25^\circ\text{C}$ and $V_{CC} = 5\text{V}$.

Note 3: $C_L = 50$ pF, $R_L = 280\Omega$, $T_A = 25^\circ\text{C}$ and $V_{CC} = 5\text{V}$.

Note 4: The symbol (\uparrow) indicates the rising edge at the clock pulse is used for reference.

Electrical Characteristics

over recommended operating free air temperature range (unless otherwise noted)

Symbol	Parameter	Conditions	Min	Typ (Note 5)	Max	Units
V_I	Input Clamp Voltage	$V_{CC} = \text{Min}$, $I_I = -18 \text{ mA}$			-1.2	V
V_{OH}	HIGH Level Output Voltage	$V_{CC} = \text{Min}$, $I_{OH} = \text{Max}$ $V_{IL} = \text{Max}$, $V_{IH} = \text{Min}$	2.7	3.4		V
V_{OL}	LOW Level Output Voltage	$V_{CC} = \text{Min}$, $I_{OL} = \text{Max}$ $V_{IH} = \text{Min}$, $V_{IL} = \text{Max}$			0.5	V
I_I	Input Current @ Max Input Voltage	$V_{CC} = \text{Max}$, $V_I = 5.5\text{V}$			1	mA
I_{IH}	HIGH Level Input Current	$V_{CC} = \text{Max}$ $V_I = 2.7\text{V}$	D		50	μA
			Clear		150	
			Preset		100	
			Clock		100	
I_{IL}	LOW Level Input Current	$V_{CC} = \text{Max}$ $V_I = 0.5\text{V}$ (Note 6)	D		-2	mA
			Clear		-6	
			Preset		-4	
			Clock		-4	
I_{OS}	Short Circuit Output Current	$V_{CC} = \text{Max}$ (Note 7)	-40		-100	mA
I_{CC}	Supply Current	$V_{CC} = \text{Max}$, (Note 8)		30	50	mA

Note 5: All typicals are at $V_{CC} = 5\text{V}$, $T_A = 25^\circ\text{C}$.

Note 6: Clear is tested with preset HIGH and preset is tested with clear HIGH.

Note 7: Not more than one output should be shorted at a time, and the duration should not exceed one second.

Note 8: With all outputs OPEN, I_{CC} is measured with the Q and \bar{Q} outputs HIGH in turn. At the time of measurement, the clock is grounded.

Switching Characteristics

at $V_{CC} = 5\text{V}$ and $T_A = 25^\circ\text{C}$

Symbol	Parameter	From (Input) To (Output)	$R_L = 280\Omega$				Units
			$C_L = 15 \text{ pF}$		$C_L = 50 \text{ pF}$		
			Min	Max	Min	Max	
f_{MAX}	Maximum Clock Frequency		75		65		MHz
t_{PLH}	Propagation Delay Time LOW-to-HIGH Level Output	Preset to Q		6		9	ns
t_{PLH}	Propagation Delay Time LOW-to-HIGH Level Output	Clear to \bar{Q}		6		9	ns
t_{PHL}	Propagation Delay Time HIGH-to-LOW Level Output (Clock HIGH)	Preset to \bar{Q}		13.5		17	ns
t_{PHL}	Propagation Delay Time HIGH-to-LOW Level Output (Clock LOW)	Preset to \bar{Q}		8		14	ns
t_{PHL}	Propagation Delay Time HIGH-to-LOW Level Output (Clock HIGH)	Clear to Q		13.5		16	ns
t_{PHL}	Propagation Delay Time HIGH-to-LOW Level Output (Clock LOW)	Clear to Q		8		13	ns
t_{PLH}	Propagation Delay Time LOW-to-HIGH Level Output	Clock to Q or \bar{Q}		9		12	ns
t_{PHL}	Propagation Delay Time HIGH-to-LOW Level Output	Clock to Q or \bar{Q}		9		14	ns

Physical Dimensions inches (millimeters) unless otherwise noted

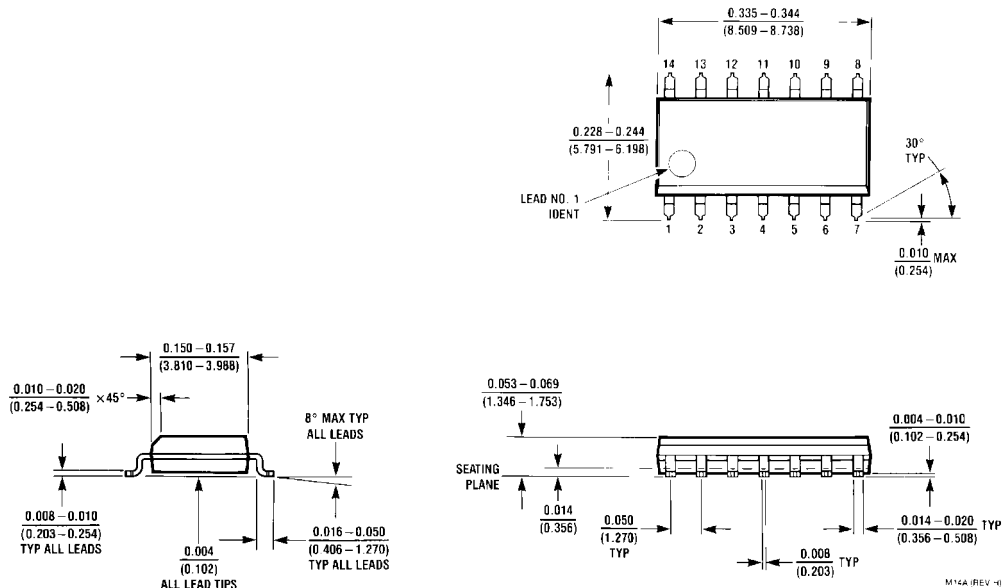

**14-Lead Small Outline Integrated Circuit (SOIC), JEDEC MS-120, 0.150 Narrow
Package Number M14A**

Physical Dimensions inches (millimeters) unless otherwise noted (Continued)

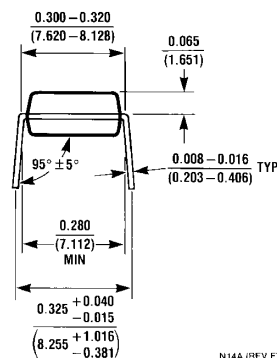
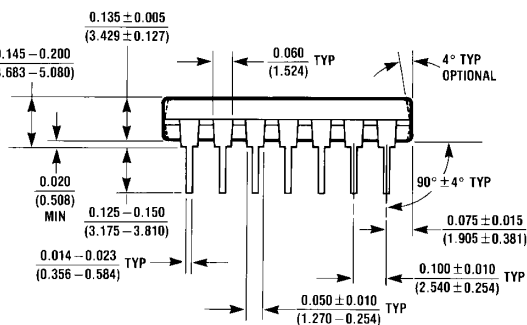
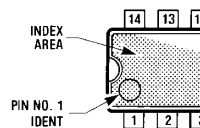
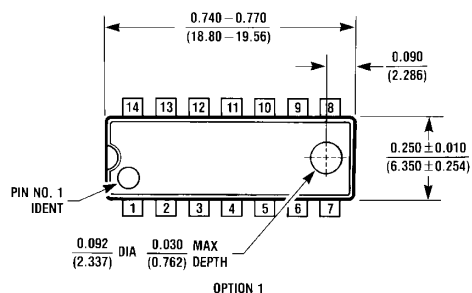

N14A (REV F)

14-Lead Plastic Dual-In-Line Package (PDIP), JEDEC MS-001, 0.300 Wide Package Number N14A

Fairchild does not assume any responsibility for use of any circuitry described, no circuit patent licenses are implied and Fairchild reserves the right at any time without notice to change said circuitry and specifications.

LIFE SUPPORT POLICY

FAIRCHILD'S PRODUCTS ARE NOT AUTHORIZED FOR USE AS CRITICAL COMPONENTS IN LIFE SUPPORT DEVICES OR SYSTEMS WITHOUT THE EXPRESS WRITTEN APPROVAL OF THE PRESIDENT OF FAIRCHILD SEMICONDUCTOR CORPORATION. As used herein:

1. Life support devices or systems are devices or systems which, (a) are intended for surgical implant into the body, or (b) support or sustain life, and (c) whose failure to perform when properly used in accordance with instructions for use provided in the labeling, can be reasonably expected to result in a significant injury to the user.
2. A critical component in any component of a life support device or system whose failure to perform can be reasonably expected to cause the failure of the life support device or system, or to affect its safety or effectiveness.

www.fairchildsemi.com