



Chipsmall Limited consists of a professional team with an average of over 10 year of expertise in the distribution of electronic components. Based in Hongkong, we have already established firm and mutual-benefit business relationships with customers from,Europe,America and south Asia,supplying obsolete and hard-to-find components to meet their specific needs.

With the principle of “Quality Parts,Customers Priority,Honest Operation,and Considerate Service”,our business mainly focus on the distribution of electronic components. Line cards we deal with include Microchip,ALPS,ROHM,Xilinx,Pulse,ON,Everlight and Freescale. Main products comprise IC,Modules,Potentiometer,IC Socket,Relay,Connector.Our parts cover such applications as commercial,industrial, and automotives areas.

We are looking forward to setting up business relationship with you and hope to provide you with the best service and solution. Let us make a better world for our industry!



Contact us

Tel: +86-755-8981 8866 Fax: +86-755-8427 6832

Email & Skype: info@chipsmall.com Web: www.chipsmall.com

Address: A1208, Overseas Decoration Building, #122 Zhenhua RD., Futian, Shenzhen, China



PHE840MB5470KB04R17

aka F840BD473K275A

Capacitor, film, 0.047 uF, +/-10% Tol, -55/+105C, Safety: X2, 275VAC,
Lead Spacing=15 mm

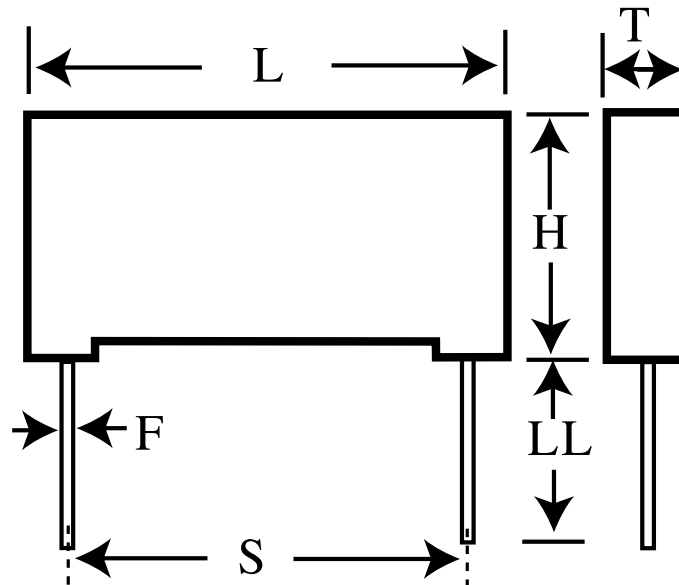

Dimensions (mm)

Specifications

ID	Dimension	Tolerance	Manufacturer:	KEMET
L	18	max	Brand:	Rifa
H	10.5	max	Capacitance:	0.047 uF
T	5.5	max	Temperature Range:	-55/+105C
S	15	+/-0.4	Rated Temperature:	105C
LL	17	nom	Voltage @ rated temp:	760V
F	0.8	nom	Voltage AC:	275VAC
			Tolerance:	+/-10%
			Body Type:	Radial Box
			Construction:	Wound
			Application:	Safety: X2
			Dissipation Factor @ 1 kHz:	0.1%
			Dissipation Factor @ 10 kHz:	0.2%
			Dissipation Factor @ 100kHz:	0.6%
			Insulation Resistance:	30 GOhm
			Maximum dVdT:	100v/us
			UL_1414:	250V
			UL_1283:	280V
			IEC_60384-14:	275V
			EN_132400:	275V
			C_22.2_NO.1:	250V
			C_22.2_NO.8:	280V
			Miscellaneous Electrical:	UL/CSA VAC= 280; fo= &DD2&"MHz series(PHE840M)
			Package Kind:	Bulk
			Package Quantity:	800