



Chipsmall Limited consists of a professional team with an average of over 10 year of expertise in the distribution of electronic components. Based in Hongkong, we have already established firm and mutual-benefit business relationships with customers from,Europe,America and south Asia,supplying obsolete and hard-to-find components to meet their specific needs.

With the principle of “Quality Parts,Customers Priority,Honest Operation,and Considerate Service”,our business mainly focus on the distribution of electronic components. Line cards we deal with include Microchip,ALPS,ROHM,Xilinx,Pulse,ON,Everlight and Freescale. Main products comprise IC,Modules,Potentiometer,IC Socket,Relay,Connector.Our parts cover such applications as commercial,industrial, and automotives areas.

We are looking forward to setting up business relationship with you and hope to provide you with the best service and solution. Let us make a better world for our industry!



Contact us

Tel: +86-755-8981 8866 Fax: +86-755-8427 6832

Email & Skype: info@chipsmall.com Web: www.chipsmall.com

Address: A1208, Overseas Decoration Building, #122 Zhenhua RD., Futian, Shenzhen, China



MD1.3 2A Dual Motor Controller SKU DRI0002



MD1.3 2A Dual Motor Controller (SKU: DRI0002)

Contents

- 1 Introduction
- 2 Specifications
- 3 Pin Out
- 4 Detailed Descriptions
 - 4.1 Motor Terminal
 - 4.2 LED
 - 4.3 Power
 - 4.4 Supply Switching Jumper
 - 4.5 Motor Control Pins
- 5 Tutorial
 - 5.1 Connection Diagram
 - 5.2 Sample Code
- 6 PWM Principle
- 7 Trouble shooting

Introduction

This is a 4.8-46V, 2A Dual Motor Controller which is the revised version of the DF-MDV1.0. Its performance has been improved greatly. It can bear larger current due to the increased heatsink dissipation. It is easy to control, using LGS's outstanding high-power motor driver chip, the L298N. This chip allows for direct drive of two bi-directional DC motors, and incorporates high-speed short

diodes for protection. Drive current up to 2A per motor output. The driver uses a broad-brush design to reduce wire resistance.

Specifications

- The logic part of the input voltage: 6 ~ 12V
- Driven part of the input voltage V_s : 4.8 ~ 46V
- The logical part of the work current I_{ss} : 36mA
- Drive part of the operating current I_o : 2A
- Maximum power dissipation: 25W ($T = 75$ degree Celsius)
- Control signal input level:
 - High level: $2.3V = V_{in} = V_{ss}$
 - Low: $-0.3V = V_{in} = 1.5V$
- Operating temperature: -25 degree Celsius ~ +130 degree Celsius
- Drive Type: Dual high-power H-bridge driver
- Module Size: 47 mm × 53mm
- Module Weight: About 29g

Pin Out

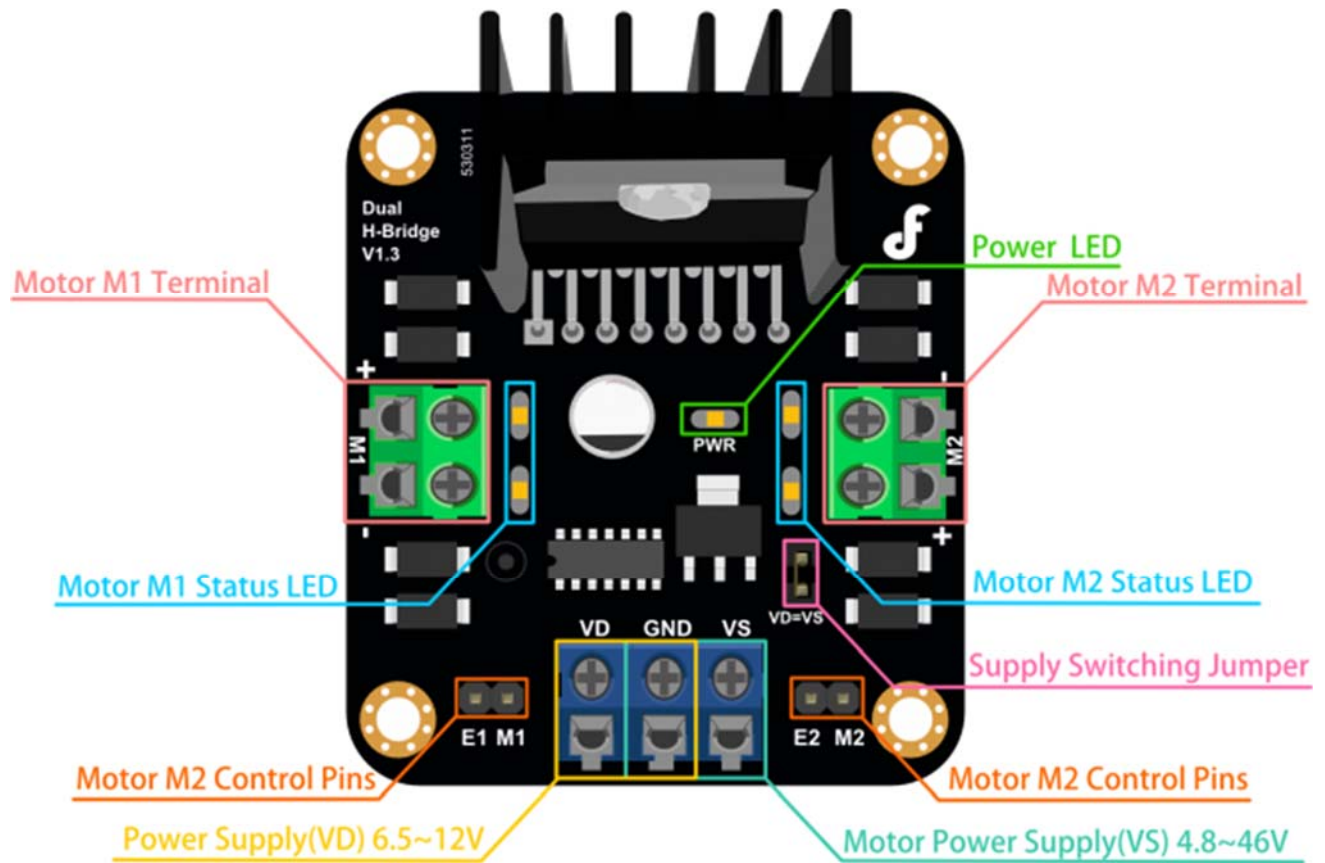

Detailed Descriptions

Motor Terminal

The terminals are used to connected to the motors, which labeled "+" and "-" representing motor polarity.

LED

PWM: Power LED

Motor Status LED: Motors work normally, thus the IED will light up.

Power

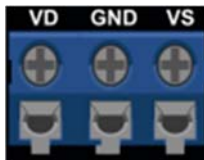

VD: Power Supply 6.5V~12V;

VS: Motor Power Supply 4.8~46V;

GND: The common ground of Logic Power Supply and Motor Supply

Supply Switching Jumper



When jumper is shorted, logic power supply voltage is the same as the motor power supply.

If motor power supply is less than 12V, you can set jumper shorted.

If motor power supply is more than 12V, dont't short jumper!

Motor Control Pins

E1,E2: Motor Enable Pin (PWM Control)

M1,M2: Motor Signal Pin. Eg: M1 = 0,the motor rotates in forward direction. M1 = 1,the motor rotates in back direction.

E	M	Run
LOW	LOW/HIGH	STOP
HIGH	HIGH	Back Direction
HIGH	LOW	Forward direction
PWM	LOW/HIGH	Speed

Note: LOW = 0; HIGH = 1; PWM = 0~255

Tutorial

This tutorial shows you how to use I298N motor drive shield to drive two DC motors.

Connection Diagram

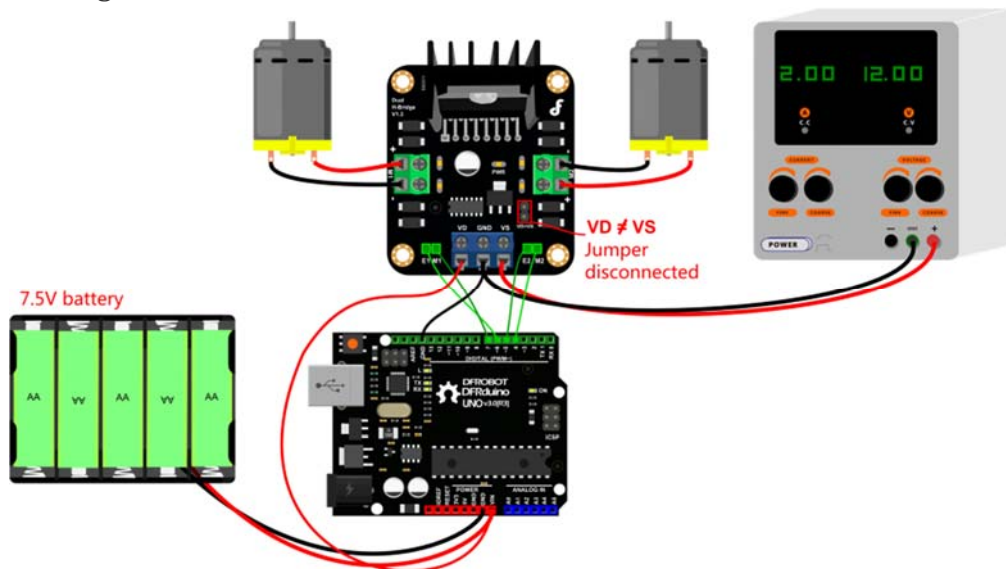

Connection Diagram

Sample Code

```
// # Editor      : Lauren from DFRobot
// # Date        : 17.02.2012

// # Product name: L298N motor driver module DF-MD v1.3
// # Product SKU : DRI0002
// # Version     : 1.0

// # Description:
// # The sketch for using the motor driver L298N
// # Run with the PWM mode

// # Connection:
// #           M1 pin  -> Digital pin 4
// #           E1 pin  -> Digital pin 5
// #           M2 pin  -> Digital pin 7
// #           E2 pin  -> Digital pin 6
// #           Motor Power Supply -> Centor blue screw connector(5.08mm 3p connector)
// #           Motor A  -> Screw terminal close to E1 driver pin
// #           Motor B  -> Screw terminal close to E2 driver pin
// #
// # Note: You should connect the GND pin from the DF-MD v1.3 to your MCU controller. They should share the GND pins.
// #

int E1 = 6;
int M1 = 7;
int E2 = 5;
int M2 = 4;

void setup()
{
    pinMode(M1, OUTPUT);
    pinMode(M2, OUTPUT);
}
```

```

}

void loop()
{
  int value;
  for(value = 0 ; value <= 255; value+=5)
  {
    digitalWrite(M1,HIGH);
    digitalWrite(M2,HIGH);
    analogWrite(E1, value); //PWM Speed Control
    analogWrite(E2, value); //PWM Speed Control
    delay(30);
  }
}

```

PWM Principle

$$\text{output_voltage} = (\text{on_time} / \text{off_time}) * \text{max_voltage}$$

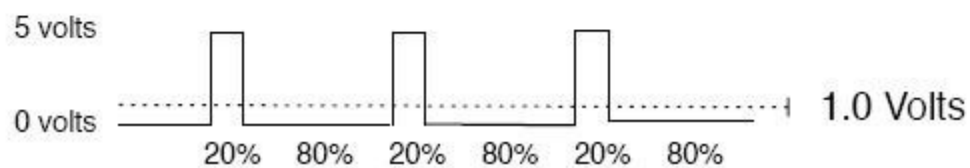
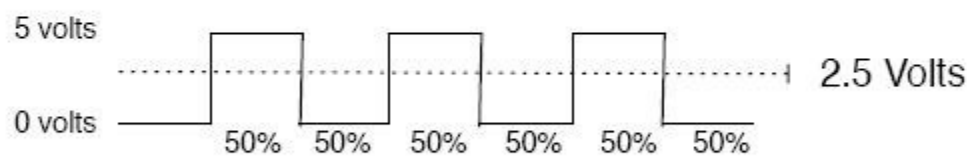
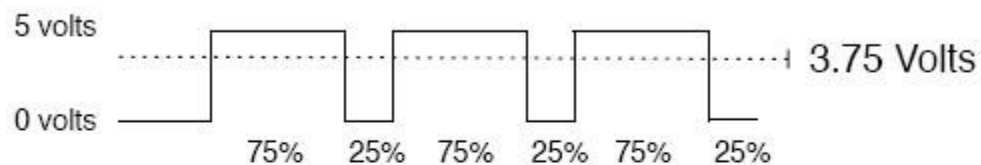

Trouble shooting

More question and cool idea, visit [DFRobot Forum](#)