



Chipsmall Limited consists of a professional team with an average of over 10 year of expertise in the distribution of electronic components. Based in Hongkong, we have already established firm and mutual-benefit business relationships with customers from,Europe,America and south Asia,supplying obsolete and hard-to-find components to meet their specific needs.

With the principle of "Quality Parts,Customers Priority,Honest Operation,and Considerate Service",our business mainly focus on the distribution of electronic components. Line cards we deal with include Microchip,ALPS,ROHM,Xilinx,Pulse,ON,Everlight and Freescale. Main products comprise IC,Modules,Potentiometer,IC Socket,Relay,Connector.Our parts cover such applications as commercial,industrial, and automotives areas.

We are looking forward to setting up business relationship with you and hope to provide you with the best service and solution. Let us make a better world for our industry!



## Contact us

Tel: +86-755-8981 8866 Fax: +86-755-8427 6832

Email & Skype: info@chipsmall.com Web: www.chipsmall.com

Address: A1208, Overseas Decoration Building, #122 Zhenhua RD., Futian, Shenzhen, China



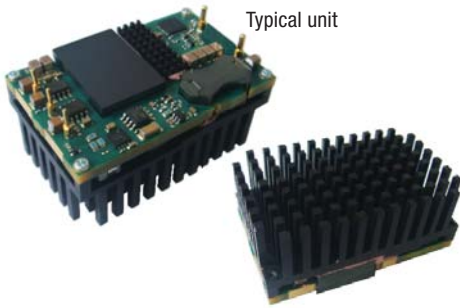

### FEATURES

- Fixed DC outputs, 12V @ 50A
- Advanced Bus Converter industry standard quarter-brick with digital PMBus™ interface
- Optional five pin version (DOSA compatible pinouts)
- 44-60 VDC input range
- Load sharing option
- Baseplate & heatsink options
- 96% typical efficiency
- 2250 VDC isolation
- Certified to UL 60950-1, CSA-C22.2 No. 60950-1, 2nd edition safety approvals
- Extensive self-protection, OVP, input undervoltage, current limiting and thermal shutdown

### PRODUCT OVERVIEW

The DRQ 600W series provides a fully regulated, digitally controlled DC output in a ¼-brick format that will support the evolving Advanced Bus Converter (ABC) industry standard footprint for isolated board mounted power modules. The DRQ series supports advances in power conversion technology including a digital interface supporting the PMBus protocol for communications to power modules.

The DRQ series offers high output current (up to 50 Amps) in an industry standard “quarter brick” package. The DRQ series is an isolated, regulated, 600W-12Vout quarter brick that has an input range of 44-60Vdc with a typical efficiency of 96%. The DRQ-12/50-L48 is ideal for intermediate bus applications.

A digitally controlled version is also available with the Advanced Bus Converter (ABC) pinout.

Advanced automated surface mount assembly

and planar magnetics deliver galvanic isolation rated at 2250 Vdc for functional insulation. Target markets include Networking Equipment, Power over Ethernet applications, Wireless Networking Equipment, Telecommunications Equipment, Wireless pre-amplifiers, Industrial and test equipment, 12V Fan trays and applications requiring a regulated 12V output.

A wealth of self-protection features include input undervoltage lockout and overtemperature shutdown; over current protection using the “hiccup” autorestart technique, provides indefinite short-circuit protection, along with output OVP. The DRQ series is certified to safety standards UL/IEC/CSA 60950-1, 2nd edition. It meets RFI/EMI conducted emission compliance to EN55022, CISPR22 with an external filter.

### APPLICATIONS

- Embedded systems, datacom and telecom installations, wireless base stations
- Disk farms, data centers and cellular repeater sites
- Remote sensor systems, dedicated controllers
- Instrumentation systems, R&D platforms, automated test fixtures
- Data concentrators, voice forwarding and speech processing systems

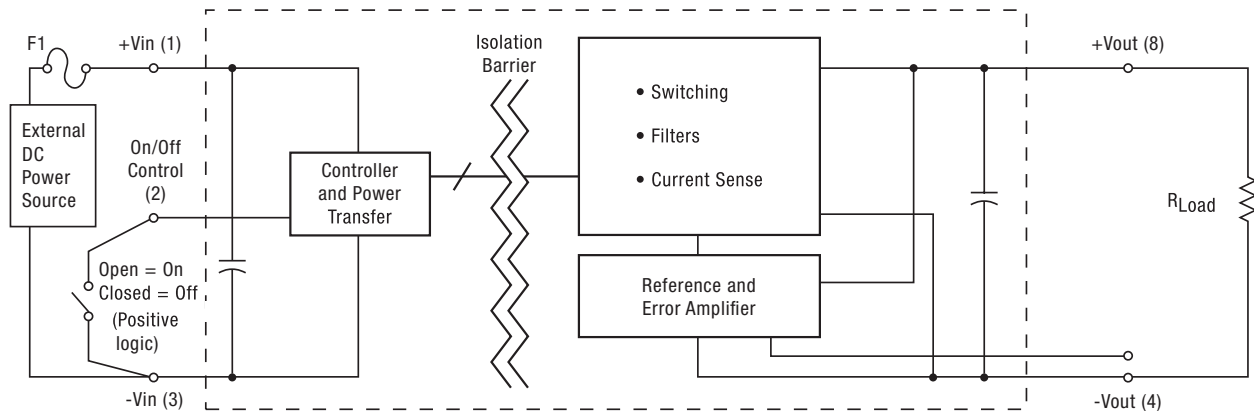

Figure 1. Connection Diagram (without digital interface)

Typical topology is shown. Murata Power Solutions recommends an external fuse.



PERFORMANCE SPECIFICATIONS SUMMARY AND ORDERING GUIDE ① ②															
Root Model ①	Output							Input				Efficiency		Dimensions with heat sink	
	V <sub>OUT</sub> (Volts)	I <sub>OUT</sub> (Amps, max.)	Power (Watts)	R/N (mV pk-pk)		Regulation (mV, max.)		V <sub>IN</sub> Nom. (Volts)	Range (Volts)	I <sub>IN</sub> no load (mA)	I <sub>IN</sub> full load (Amps)	Min.	Typ.	(inches)	(mm)
				Typ.	Max.	Line	Load								
DRQ-12/50-L48	12	50	600	150	200	100	120	48	44-60	150	13.02	95%	96%	2.3 x 1.45 x 1.1	58.4 x 36.8 x 27.94

① Please refer to the part number structure for additional ordering information and options.  
 ② All specifications are typical at nominal line voltage and full load, +25°C unless otherwise noted. See

detailed specifications. Output capacitors are 1 µF || 10 µF. These caps are necessary for our test equipment and may not be needed for your application.

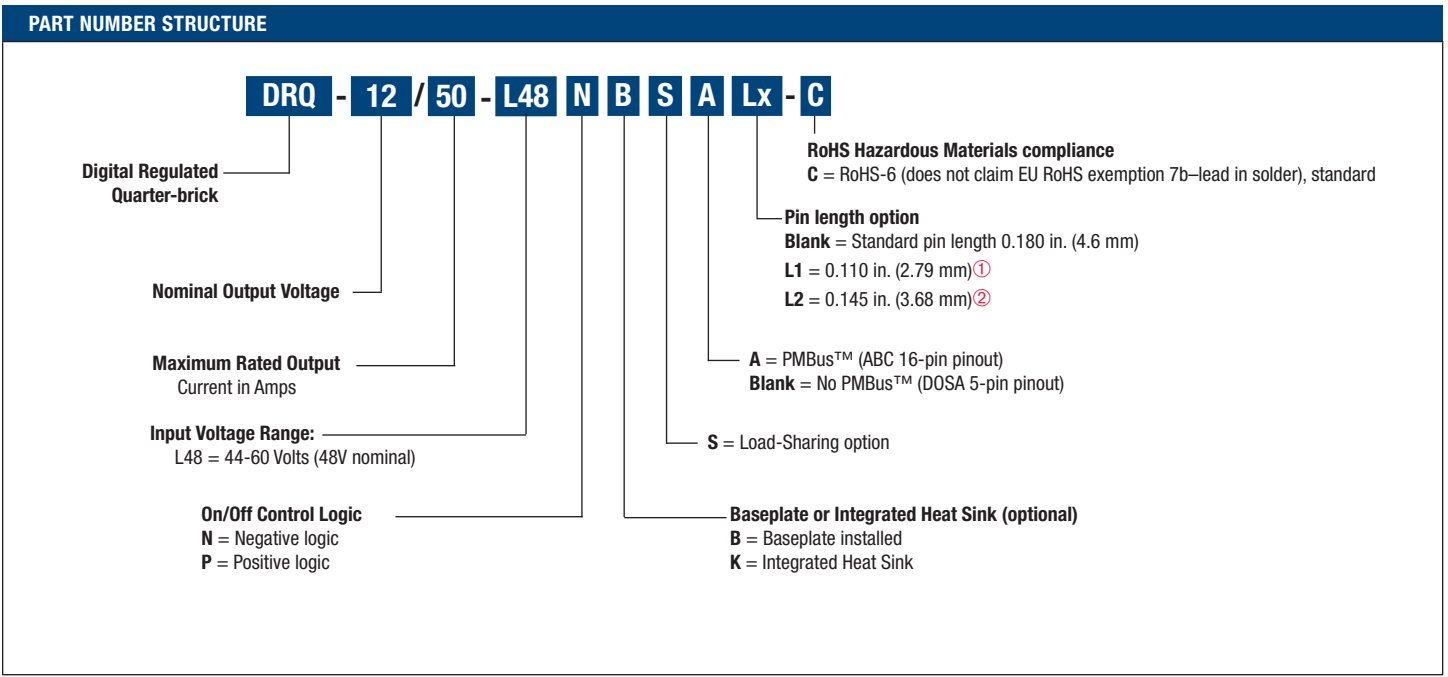

- ① Special quantity order is required; samples available with standard pin length only.
- ② Some model number combinations may not be available. See website or contact your local Murata sales representative.

**Complete Model Number Example:** **DRQ-12/50-L48NKL1-C**  
 Negative On/Off logic, Integrated Heat Sink installed, 0.110" pin length, RoHS-6 compliance

### FUNCTIONAL SPECIFICATIONS

ABSOLUTE MAXIMUM RATINGS	Conditions ①	Minimum	Typical/Nominal	Maximum	Units
Input Voltage, Continuous		0		60	Vdc
Isolation Voltage	Input to output, continuous			2250	Vdc
On/Off Remote Control	Power on, referred to -Vin	0		13.5	Vdc
Output Power		0		612	W
Output Current	Current-limited, no damage, short-circuit protected	0		50	A
Storage Temperature Range	Vin = Zero (no power)	-55		125	°C
Absolute maximums are stress ratings. Exposure of devices to greater than any of these conditions may adversely affect long-term reliability. Proper operation under conditions other than those listed in the Performance/Functional Specifications Table is not implied or recommended.					
INPUT	Conditions ① ③				
Operating voltage range		44	48	60	Vdc
Recommended External Fuse	Fast blow		25		A
Start-up threshold	Rising input voltage	41	42	43	Vdc
Undervoltage shutdown	Falling input voltage	39	40	41	Vdc
Overvoltage Shutdown		64	66	68	Vdc
Overvoltage Recover		62	64	66	Vdc
Internal Filter Type			Pi		
Input current					
Full Load Conditions	Vin = nominal		13.02	14.02	A
Low Line	Vin = minimum		14.2	14.28	A
Inrush Transient			0.15	0.30	A <sup>2</sup> -Sec.
Short Circuit Input Current			0.05	0.1	A
No Load Input Current	Iout = minimum, unit = ON		150	200	mA
Shut-Down Input Current (Off, UV, OT)			10	20	mA
Reflected (back) ripple current ②	Measured at input with specified filter		100	180	mA, p-p
Pre-biased startup	External output voltage < Vset		Monotonic		
GENERAL and SAFETY					
Efficiency	Vin = 48V, full load	95	96		%
	Vin = min., full load	95.5	96		%
Isolation					
Isolation Voltage	Input to output, continuous			2250	Vdc
Isolation Voltage	Input to baseplate, continuous			1500	Vdc
Isolation Voltage	Output to baseplate, continuous			1500	Vdc
Insulation Safety Rating			functional		
Isolation Resistance			10		MΩ
Isolation Capacitance			1500		pF
Safety	Certified to UL-60950-1, CSA-C22.2 No. 60950-1, IEC 60950-1, 2nd edition		Yes		
Calculated MTBF	Per Telcordia SR332, issue 2, class 3, method 1, ground fixed, Tambient = +25°C		3.2		Hours x 10 <sup>6</sup>
DYNAMIC CHARACTERISTICS					
Fix Frequency Control			150		KHz
Vin Startup delay time	Power on to Vout regulated		25	30	mS
Enable startup delay time	Remote ON to Vout regulated		3	5	mS
Rise Time			15	20	mS
Dynamic Load Response	50-75-50% load step, settling time to within 1% of Vout (Cout=3300μF)		200	250	μSec
Dynamic Load Peak Deviation	same as above		±250	±300	mV
FEATURES and OPTIONS					
Remote On/Off Control ④					
"N" suffix:					
Negative Logic, ON state	ON = Ground pin or external voltage	-0.1		0.8	V
Negative Logic, OFF state	OFF = Pin open or external voltage	3.5		13.5	V
Control Pin Shutdown Current	Open collector/drain			5	mA
Control Pin On Current				1	mA
"P" suffix:					
Positive Logic, ON state	ON = Pin open or external voltage	3.5		13.5	V
Positive Logic, OFF state	OFF = Ground pin or external voltage	0		0.8	V
Control Pin Shutdown Current	Open collector/drain			1	mA
Control Pin On Current				5	mA

### FUNCTIONAL SPECIFICATIONS, (CONT.)

OUTPUT	Conditions ①	Minimum	Typical/Nominal	Maximum	Units
<b>Total Output Power</b>		0	600	612	W
<b>Voltage</b>					
<b>Nominal Output Voltage</b>	No trim, all conditions	11.76	12	12.24	Vdc
<b>Setting Accuracy</b>	At 50% load, no trim	-2		2	% of Vnom
<b>Output Voltage</b>	@Vin=48V, Iout=0, Ta=+25°C	11.95		12.05	Vdc
<b>Overvoltage Protection</b>	Via magnetic feedback	13.8	14.4	15.6	Vdc
<b>Current</b>					
<b>Output Current Range</b>		0		50	A
<b>Minimum Load</b>					
<b>Current Limit Inception</b>	90% of Vout, after warmup	56	58	60	A
<b>Short Circuit</b>					
<b>Short Circuit Current</b>	Hiccup technique, autorecovery within ±1.25% of Vout		0.4	1	A
<b>Short Circuit Duration (remove short for recovery)</b>	Output shorted to ground, no damage		Continuous		
<b>Short circuit protection method</b>	Current limiting				
<b>Regulation ⑤</b>					
<b>Line Regulation</b>			40	100	mV
<b>Load Regulation</b>	Iout = min. to max.		40	120	mV
<b>Ripple and Noise ⑥</b>	5 Hz- 20 MHz BW		150	200	mV pk-pk
<b>Temperature Coefficient</b>	At all outputs			±0.02	% of Vout./°C
<b>Maximum Capacitive Loading</b>	Low ESR			10,000	µF
<b>MECHANICAL (Through Hole Models)</b>					
<b>Outline Dimensions with heat sink</b>			2.3 x 1.45 x 1.1		Inches
(Please refer to outline drawing)	LxWxH		58.4 x 36.83 x 27.94		mm
<b>Outline Dimensions with baseplate</b>			2.3 x 1.45 x .052		Inches
(Please refer to outline drawing)	LxWxH		58.4x 36.83x 13.2		mm
<b>Weight with heat sink</b>			3.38		Ounces
			96		Grams
<b>Weight with baseplate</b>			2.63		Ounces
			74.5		Grams
<b>Through Hole Pin Diameter</b>			0.04 & 0.062		Inches
			1.016 & 1.575		mm
<b>Through Hole Pin Material</b>			Copper alloy		
<b>TH Pin Plating Metal and Thickness</b>	Nickel subplate		98.4-299		µ-inches
	Gold overplate		4.7-19.6		µ-inches
<b>ENVIRONMENTAL</b>					
<b>Operating Ambient Temperature Range</b>	See Derating	-40		85	°C
<b>Operating Case Temperature</b>	No derating	-40		110	°C
<b>Storage Temperature</b>	Vin = Zero (no power)	-55		125	°C
<b>Thermal Protection/Shutdown</b>	Measured in center		135		°C
<b>Electromagnetic Interference</b>	External filter is required				
<b>Conducted, EN55022/CISPR22</b>			B		Class
<b>RoHS rating</b>			RoHS-6		

### Notes

- ① Unless otherwise noted, all specifications apply at Vin = nominal, nominal output voltage and full output load. General conditions are near sea level altitude, no base plate installed and natural convection airflow unless otherwise specified. All models are tested and specified with external parallel 1 µF and 10 µF output capacitors (see Technical Notes). All capacitors are low-ESR types wired close to the converter. These capacitors are necessary for our test equipment and may not be needed in the user's application.
- ② Input (back) ripple current is tested and specified over 5 Hz to 20 MHz bandwidth. Input filtering is Cin = 33 µF/100V, Cbus = 220µF/100V and Lbus = 12 µH.
- ③ All models are stable and regulate to specification under no load.
- ④ The Remote On/Off Control is referred to -Vin.
- ⑤ Regulation specifications describe the output voltage changes as the line voltage or load current is varied from its nominal or midpoint value to either extreme. The load step is ±25% of full load current.
- ⑥ Output Ripple and Noise is measured with Cout = 1 µF || 10 µF, 20 MHz oscilloscope bandwidth and full resistive load.

## PERFORMANCE DATA

Efficiency vs. Line Voltage and Load Current @ +25°C

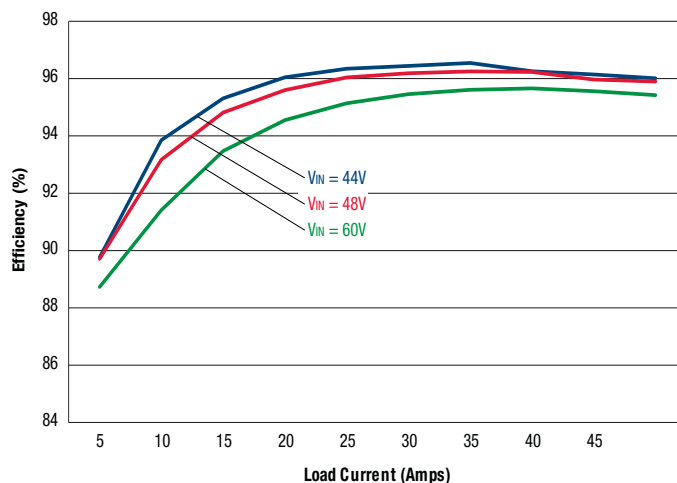

Maximum Current Temperature Derating at sea level  
(Vin = 44V, airflow from -Vin to +Vin, with heat sink)

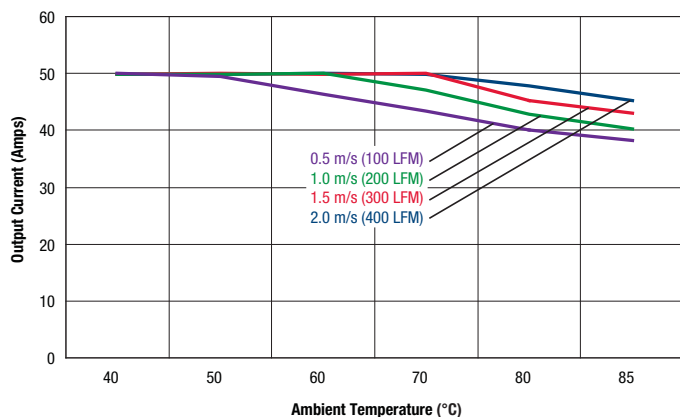

Maximum Current Temperature Derating at sea level  
(Vin = 48V, airflow from -Vin to +Vin, with heat sink)

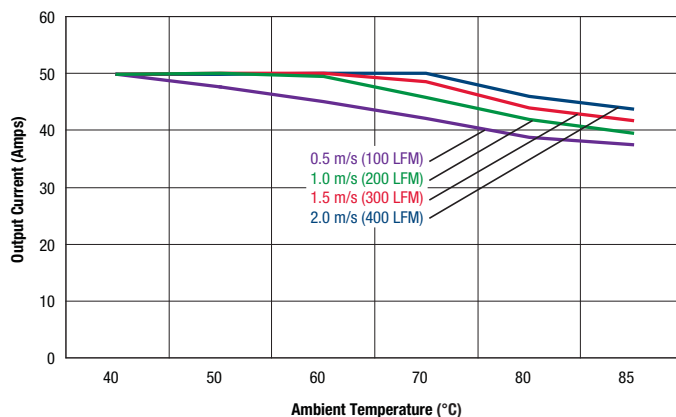

Maximum Current Temperature Derating at sea level  
(Vin = 54V, airflow from -Vin to +Vin, with heat sink)

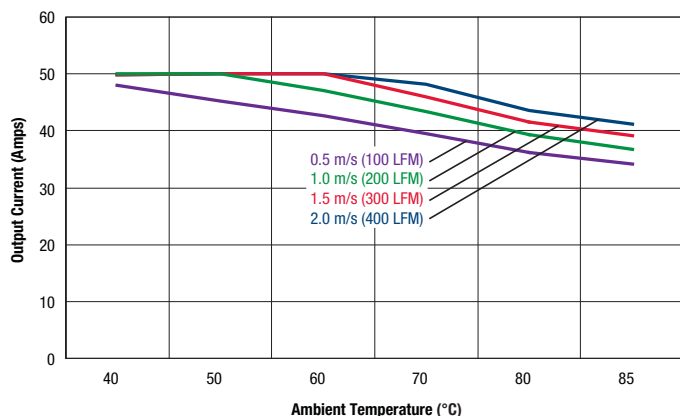

Maximum Current Temperature Derating at sea level  
(Vin = 60V, airflow from -Vin to +Vin, with heat sink)

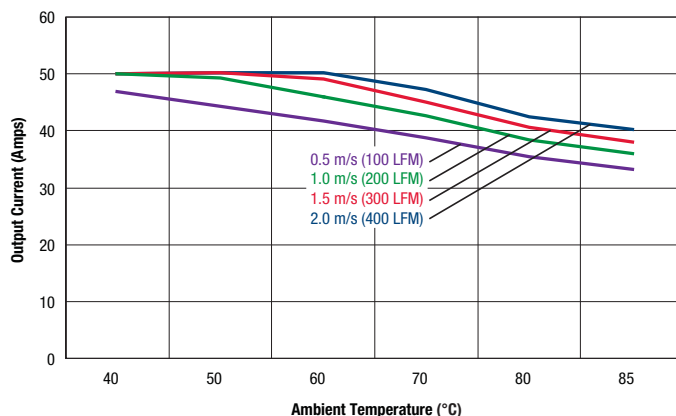

**PERFORMANCE DATA**

Transverse

Longitudinal

Maximum Current Temperature Derating at sea level  
(Vin = 44V, airflow from -Vin to +Vin, with baseplate)

Maximum Current Temperature Derating at sea level  
(Vin = 44V, airflow from Vin to Vout, with baseplate)

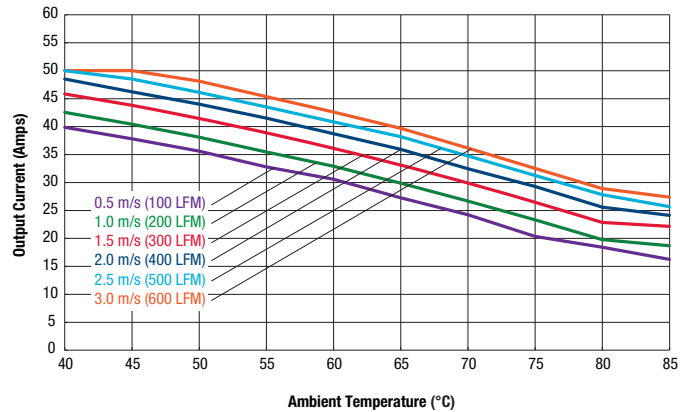
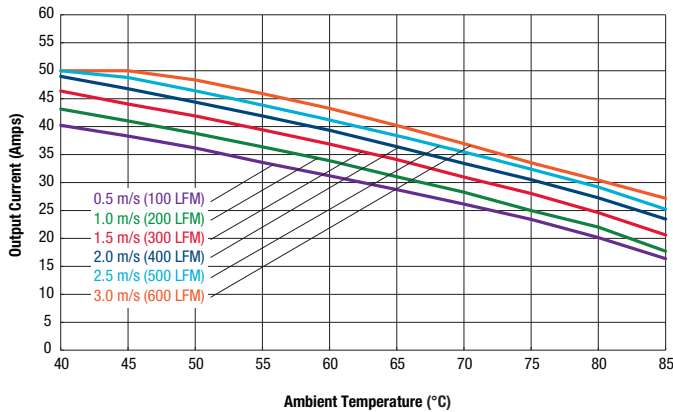

Maximum Current Temperature Derating at sea level  
(Vin = 48V, airflow from -Vin to +Vin, with baseplate)

Maximum Current Temperature Derating at sea level  
(Vin = 48V, airflow from Vin to Vout, with baseplate)

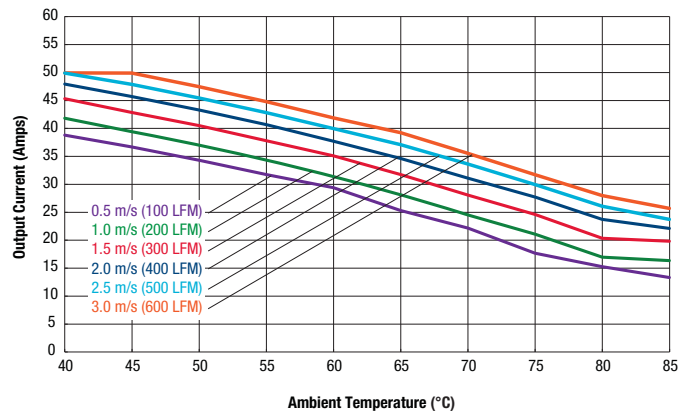
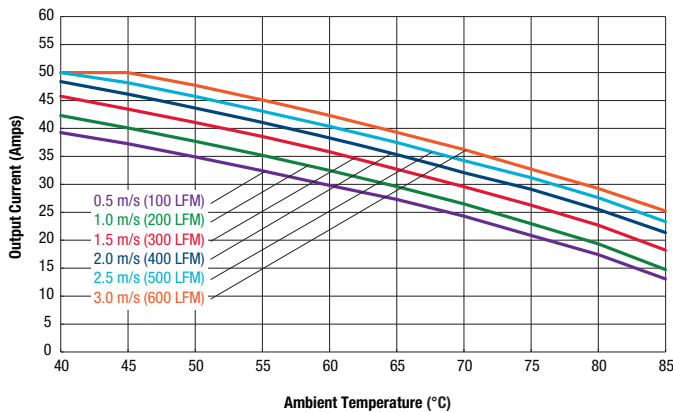

Maximum Current Temperature Derating at sea level  
(Vin = 60V, airflow from -Vin to +Vin, with baseplate)

Maximum Current Temperature Derating at sea level  
(Vin = 60V, airflow from Vin to Vout, with baseplate)

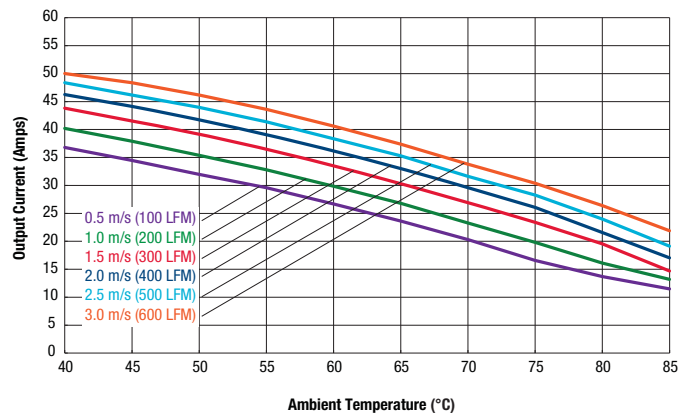
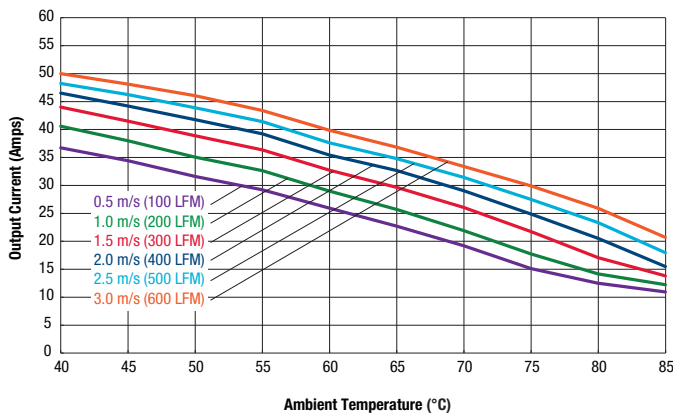

## PERFORMANCE DATA

Enable Startup Delay (Vin = 48V, Iout = 50A, Cout = 10000µF, Ta = +25°C)  
Ch2 = Vout, Ch4 = Enable.

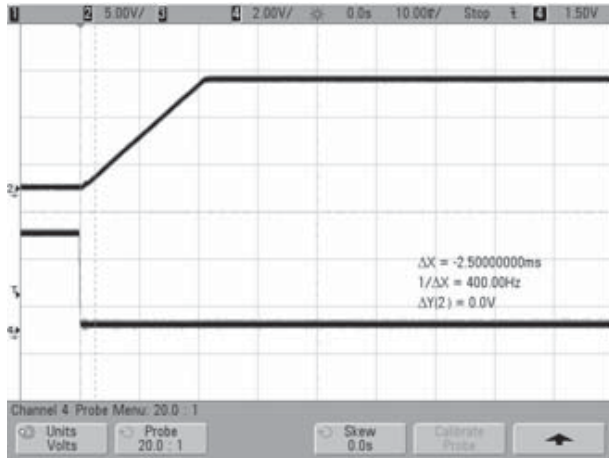

Startup Delay (Vin = 48V, Iout = 50A, Cout = 10000µF, Ta = +25°C)  
Ch1 = Vin, Ch2 = Vout.

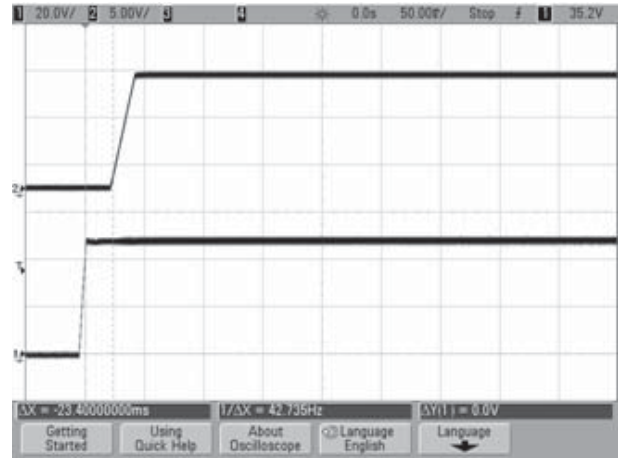

Stepload Transient Response (Vin = 48V, Iout = 50-75-50% of Iout, Load = 1000µF)

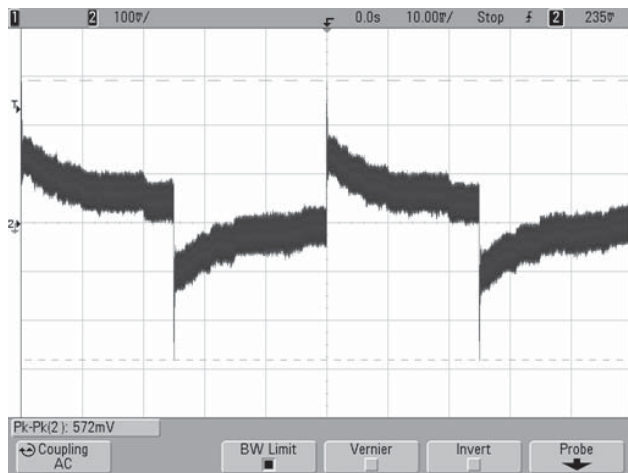

Stepload Transient Response (Vin = 48V, Iout = 25-75-25% of Iout, Load = 1000µF)

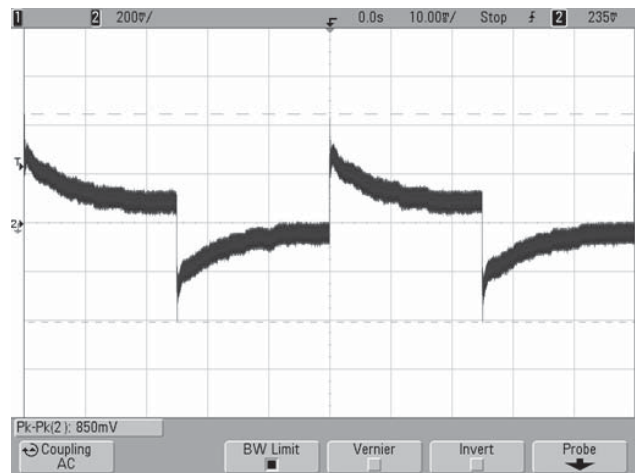

Output Ripple & Noise (Vin = 48V, Iout = 0A, Cout = 1µF || 10µF, Ta = +25°C)

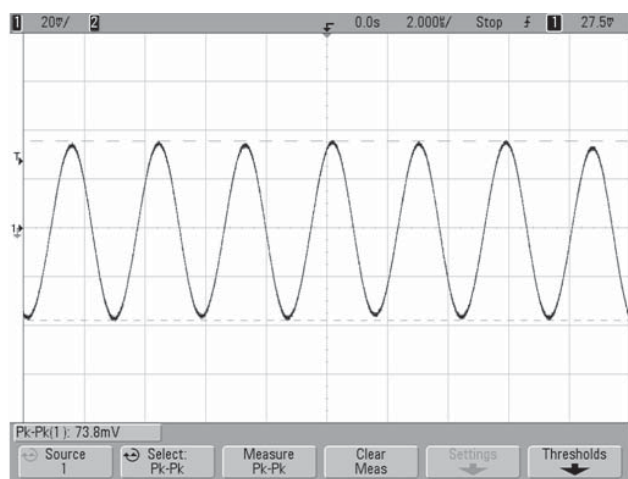

Output Ripple & Noise (Vin = 48V, Iout = 50A, Cout = 1µF || 10µF, Ta = +25°C)

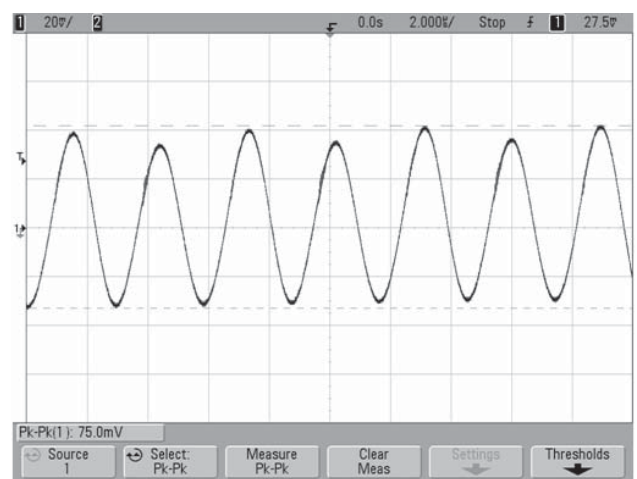



**PERFORMANCE DATA**

Output v. Input Voltage @ No Load

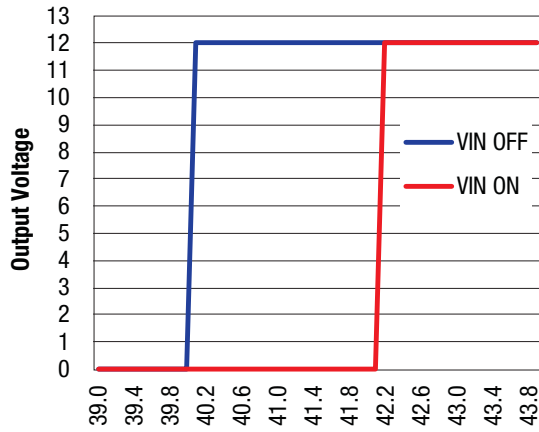

Output v. Input Voltage @ 50% Load

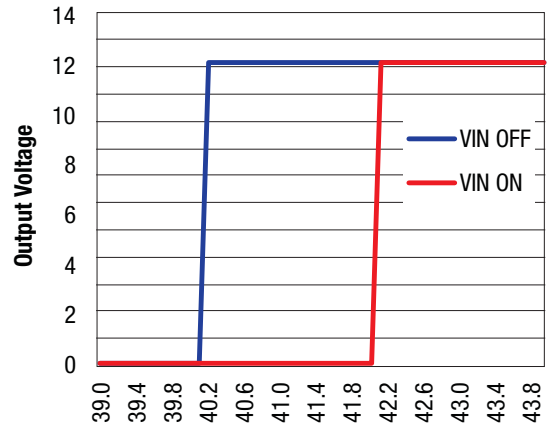

Output v. Input Voltage @ Full Load

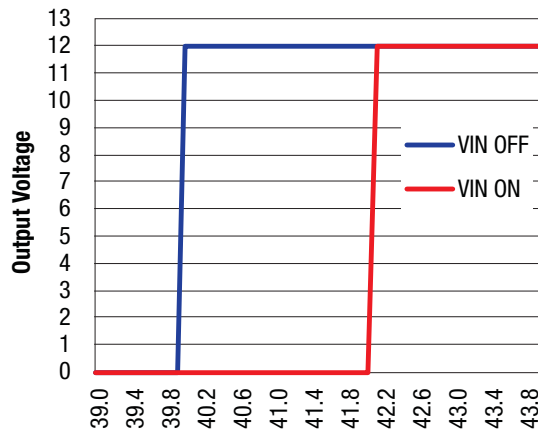

**ABC (PMBUS) MECHANICAL SPECIFICATIONS WITH HEAT SINK**

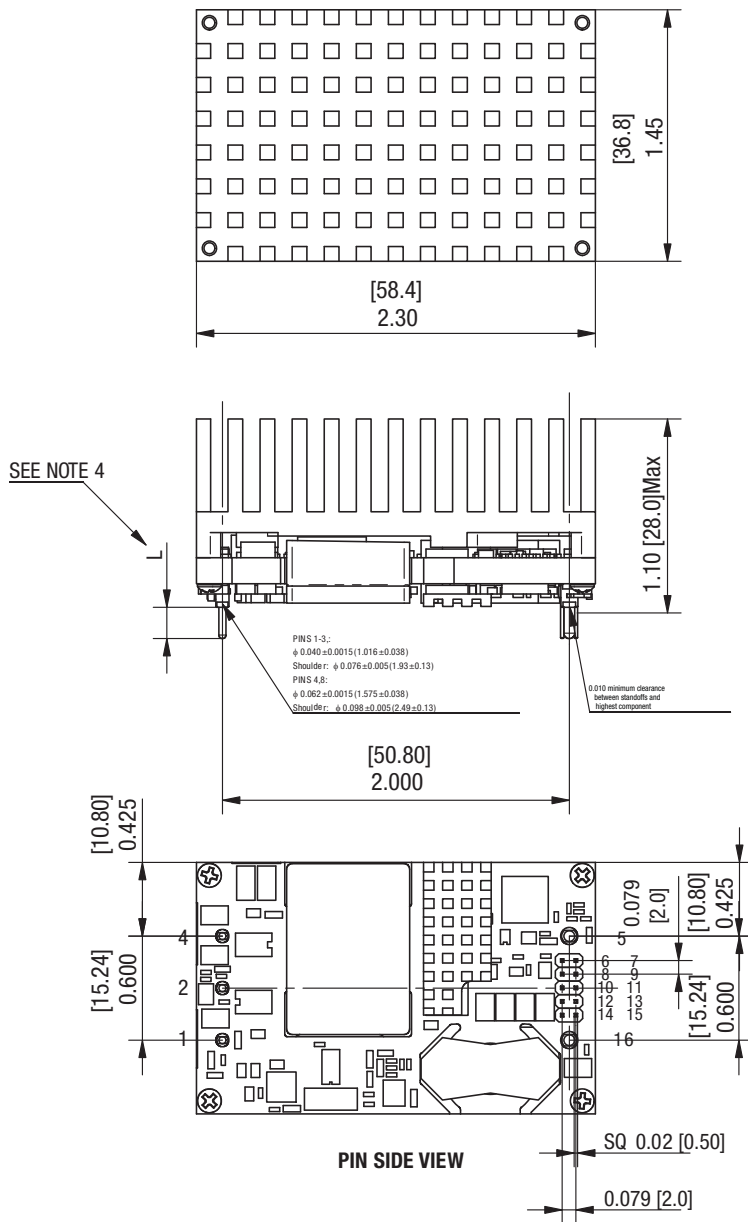

- NOTES:  
 UNLESS OTHERWISE SPECIFIED:  
 1: ALL DIMENSIONS ARE IN INCHES [MILLIMETERS];  
 2: ALL TOLERANCES:  $x.xx \times in, \pm 0.02in$  ( $x.xxmm, \pm 0.5mm$ )  
 $x.xxx \times in, \pm 0.01in$  ( $x.xxxmm, \pm 0.25mm$ )  
 3: COMPONENTS WILL VARY BETWEEN MODELS  
 4: STANDARD PIN LENGTH: 0.180 Inch  
 FOR PIN LENGTH OPTIONS, SEE PART NUMBER STRUCTURE.

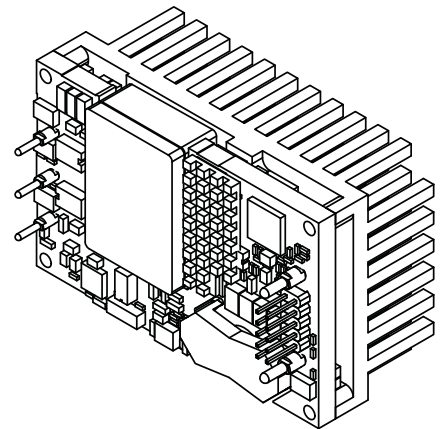

ISOMETRIC VIEW

INPUT/OUTPUT CONNECTIONS		
Pin	Designation	Function
1	+VIN	Positive Input
2	On/Off 1 Control	Primary On/Off Control
3	No Pin	No Pin
4	-VIN	Negative Input
5	-VOUT	Negative Output
6	+S	Positive Remote Sense
7	-S	Negative Remote Sense
8	SA0	Address Pin 0
9	SA1	Address Pin 1
10	SCL	PMBus Clock
11	SDA	PMBus Data
12	PG	Power Good Output
13	DGND	PMBus Ground
14	SMBALERT	PMBus Alert Signal
15	On/Off 2 Control	Secondary On/Off Control
16	+VOUT	Positive Output

Dimensions are in inches (mm) shown for ref. only.

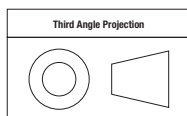

Tolerances (unless otherwise specified):  
 .XX  $\pm 0.02$  (0.5)  
 .XXX  $\pm 0.010$  (0.25)  
 Angles  $\pm 2^\circ$

**ABC (PMBUS) MECHANICAL SPECIFICATIONS WITH BASEPLATE**

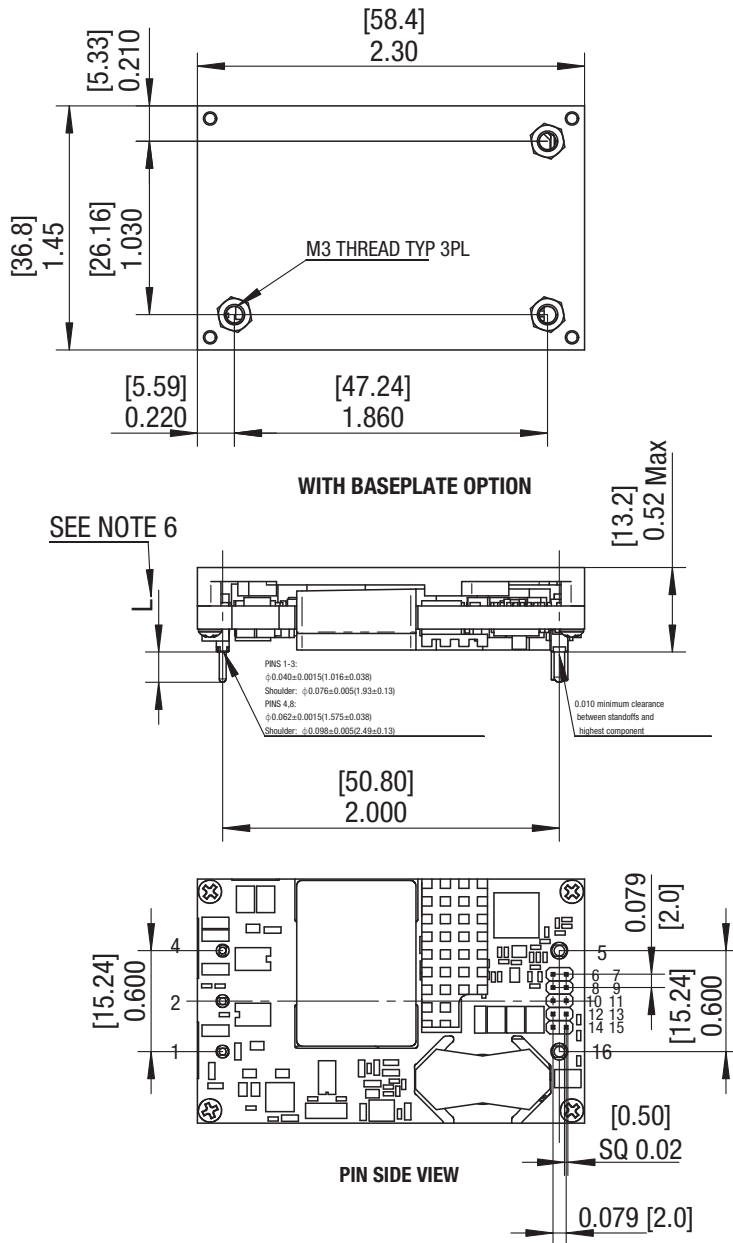

**NOTES:**

UNLESS OTHERWISE SPECIFIED:

- 1: M3 SCREW USED TO BOLT UNIT'S BASEPLATE TO OTHER SURFACES (SUCH AS HEATSINK) MUST NOT EXCEED 0.11"(2.8mm) DEPTH BELOW THE SURFACE OF BASEPLATE
- 2: APPLIED TORQUE PER SCREW SHOULD NOT EXCEED 5.3In-lb (0.6Nm);
- 3: ALL DIMENSIONS ARE IN INCHES [MILLIMETERS];
- 4: ALL TOLERANCES: x.x×in, ±0.02in (x.x×mm, ±0.5mm)  
x.x××in, ±0.01in (x.x××mm, ±0.25mm)
- 5: COMPONENTS WILL VARY BETWEEN MODELS
- 6: STANDARD PIN LENGTH: 0.180 Inch  
FOR PIN LENGTH OPTIONS, SEE PART NUMBER STRUCTURE.

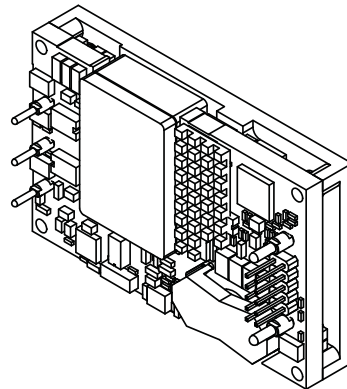

**INPUT/OUTPUT CONNECTIONS**

Pin	Designation	Function
1	+VIN	Positive Input
2	On/Off 1 Control	Primary On/Off Control
3	No Pin	No Pin
4	-VIN	Negative Input
5	-VOUT	Negative Output
6	+S	Positive Remote Sense
7	-S	Negative Remote Sense
8	SA0	Address Pin 0
9	SA1	Address Pin 1
10	SCL	PMBus Clock
11	SDA	PMBus Data
12	PG	Power Good Output
13	DGND	PMBus Ground
14	SMBALERT	PMBus Alert Signal
15	On/Off 2 Control	Secondary On/Off Control
16	+VOUT	Positive Output

Dimensions are in inches (mm) shown for ref. only.

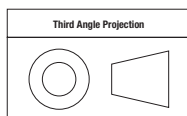

Tolerances (unless otherwise specified):  
 .XX ± 0.02 (0.5)  
 .XXX ± 0.010 (0.25)  
 Angles ± 2°

ABC (PMBUS) RECOMMENDED FOOTPRINT

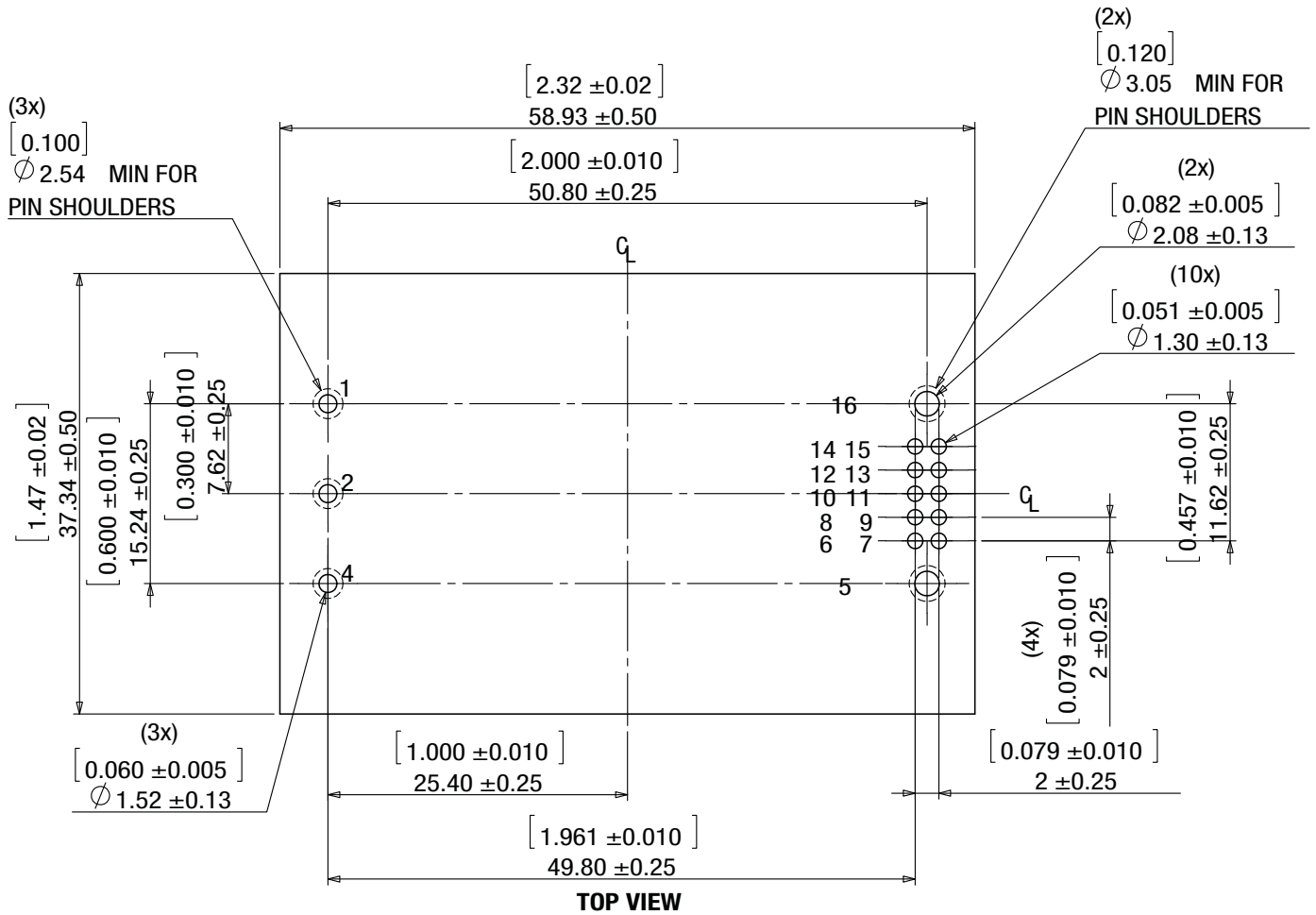

**MECHANICAL SPECIFICATIONS (NO PMBUS) WITH HEAT SINK**

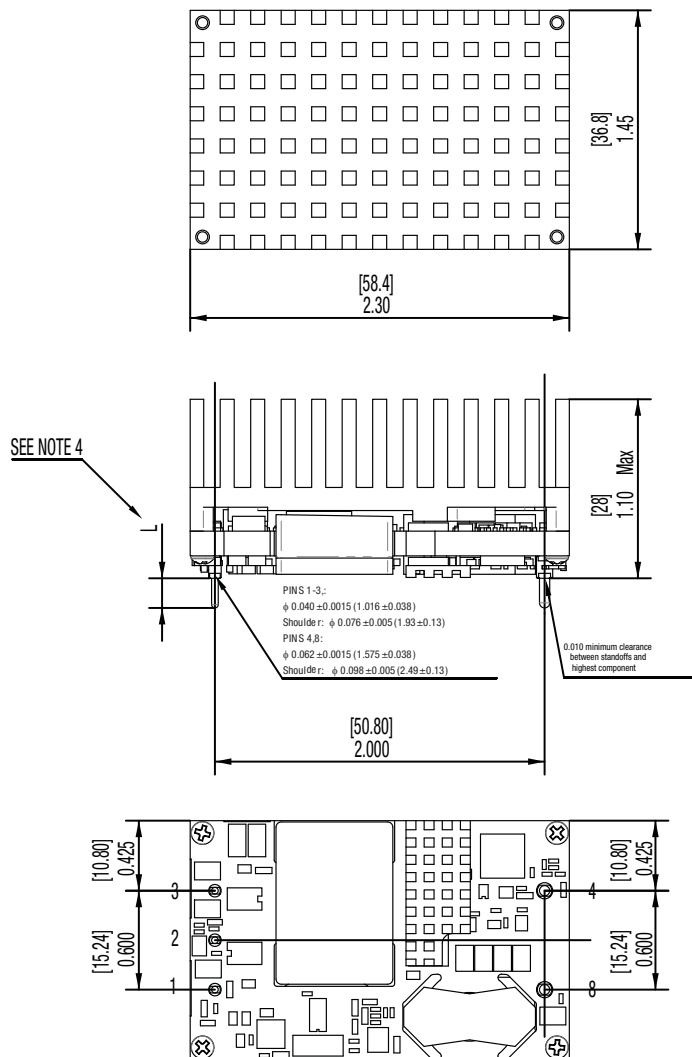

**PIN SIDE VIEW**

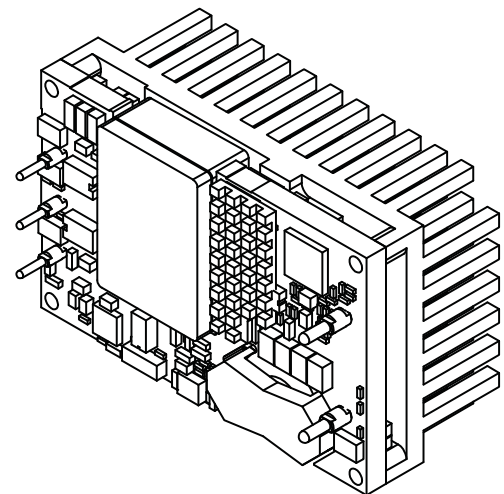

**ISOMETRIC VIEW**

Dimensions are in inches (mm) shown for ref. only.

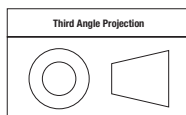

Tolerances (unless otherwise specified):  
 .XX  $\pm$  0.02 (0.5)  
 .XXX  $\pm$  0.010 (0.25)  
 Angles  $\pm 2^\circ$

**NOTES:**

UNLESS OTHERWISE SPECIFIED:

- 1: ALL DIMENSIONS ARE IN INCHES [MILLIMETERS];
- 2: ALL TOLERANCES:  $x.x \times \text{in}$ ,  $\pm 0.02 \text{in}$  ( $x.x \text{mm}$ ,  $\pm 0.5 \text{mm}$ )  
 $x.x \times \text{in}$ ,  $\pm 0.01 \text{in}$  ( $x.x \text{mm}$ ,  $\pm 0.25 \text{mm}$ )
- 3: COMPONENTS WILL VARY BETWEEN MODELS
- 4: STANDARD PIN LENGTH: 0.180 Inch  
 FOR PIN LENGTH OPTIONS, SEE PART NUMBER STRUCTURE.
- 5: DOSA 5 PIN COMPATIBLE

I/O Connections	
Pin	Function
1	+Vin
2	Remote On/Off Control
3	-Vin
4	-Vout
8	+Vout

**MECHANICAL SPECIFICATIONS (NO PMBUS) WITH BASEPLATE**

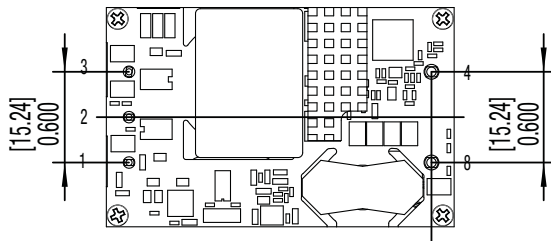
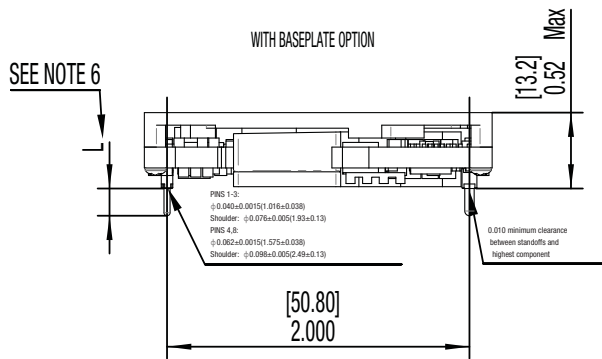
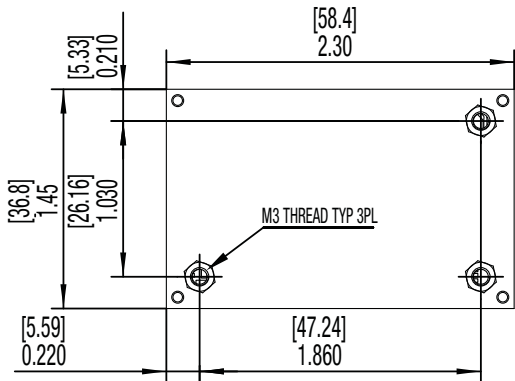

**PIN SIDE VIEW**

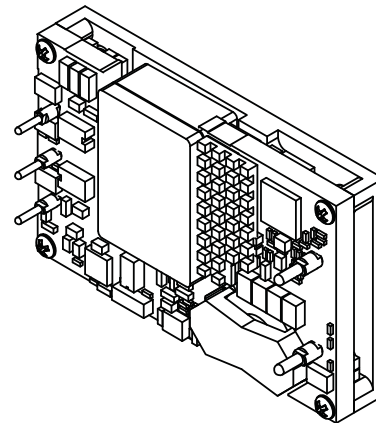

**ISOMETRIC VIEW**

**NOTES:**

UNLESS OTHERWISE SPECIFIED:

- 1: M3 SCREW USED TO BOLT UNIT'S BASEPLATE TO OTHER SURFACES (SUCH AS HEATSINK) MUST NOT EXCEED 0.11"(2.8mm) DEPTH BELOW THE SURFACE OF BASEPLATE
- 2: APPLIED TORQUE PER SCREW SHOULD NOT EXCEED 5.3In-lb (0.6Nm);
- 3: ALL DIMENSIONS ARE IN INCHES [MILLIMETERS];
- 4: ALL TOLERANCES:  $x.x \times \text{in}$ ,  $\pm 0.02 \text{in}$  ( $x.x \times \text{mm}$ ,  $\pm 0.5 \text{mm}$ )  
 $x.x \times \text{in}$ ,  $\pm 0.01 \text{in}$  ( $x.x \times \text{mm}$ ,  $\pm 0.25 \text{mm}$ )
- 5: COMPONENTS WILL VARY BETWEEN MODELS
- 6: STANDARD PIN LENGTH: 0.180 Inch  
FOR PIN LENGTH OPTIONS, SEE PART NUMBER STRUCTURE.
- 7: DOSA 5 PIN COMPATIBLE

Dimensions are in inches (mm) shown for ref. only.

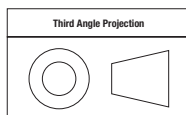

Tolerances (unless otherwise specified):  
 .XX  $\pm 0.02$  (0.5)  
 .XXX  $\pm 0.010$  (0.25)  
 Angles  $\pm 2^\circ$

**I/O Connections**

Pin	Function
1	+Vin
2	Remote On/Off Control
3	-Vin
4	-Vout
8	+Vout

**RECOMMENDED FOOTPRINT (NO PMBUS)**

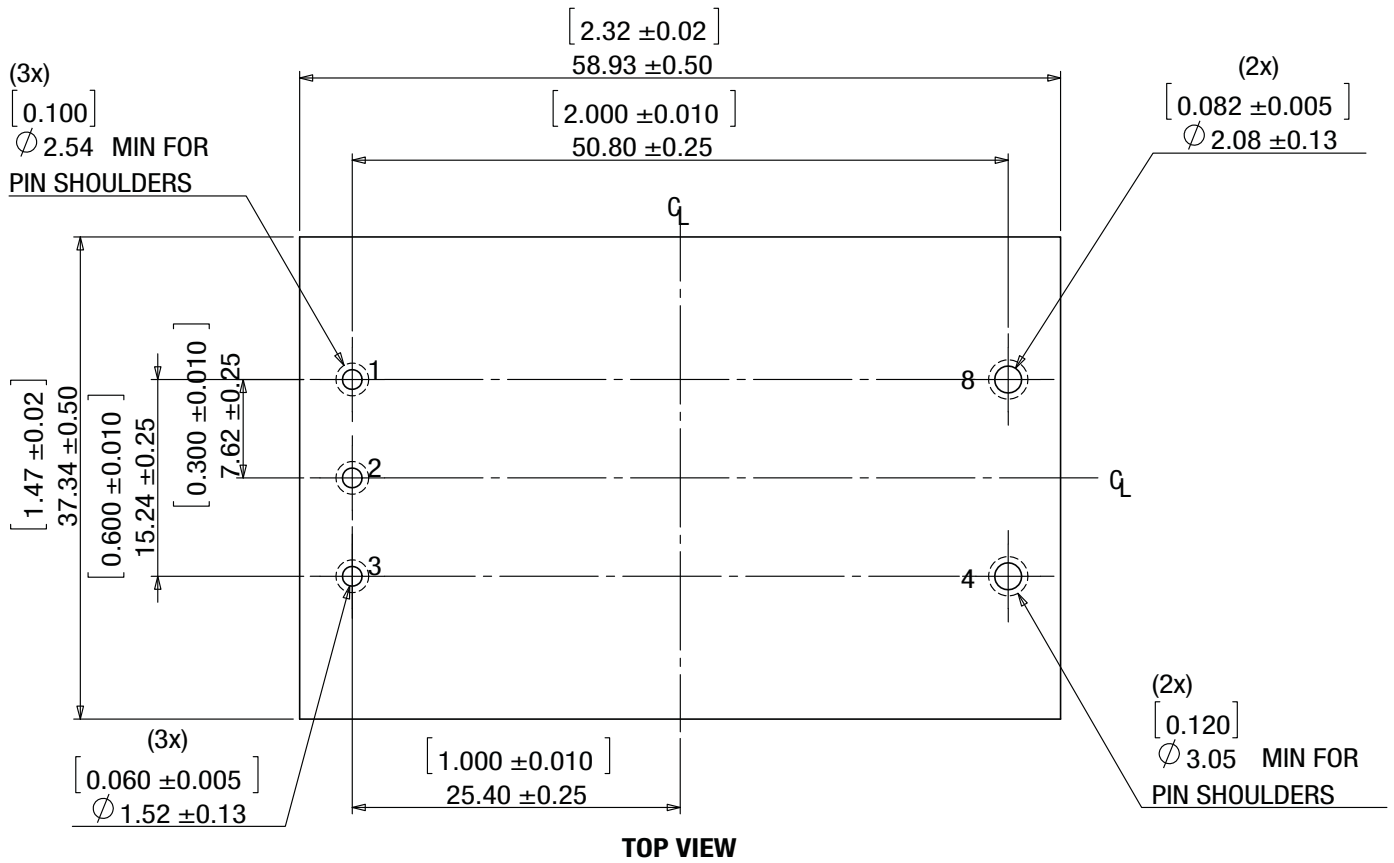

**STANDARD PACKAGING**

**BASEPLATE VERSION**

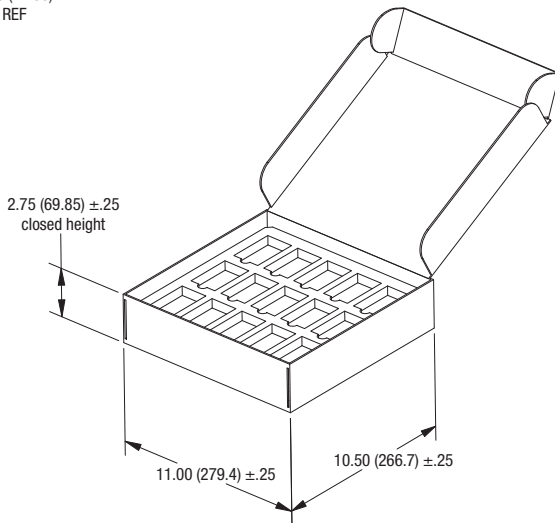
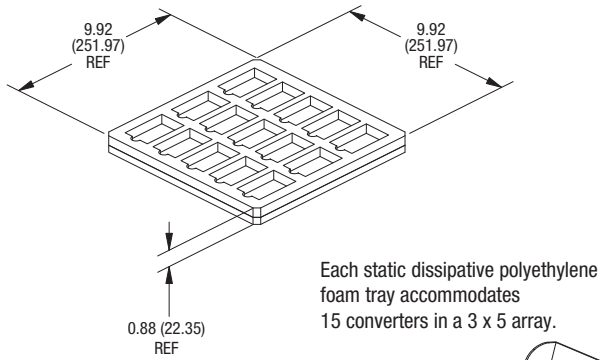

Carton accommodates two (2) trays yielding 30 converters per carton

**HEATSINK VERSION**

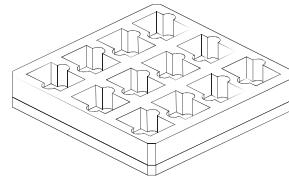

Each static dissipative polyethylene foam tray accommodates 12 converters in a 3 x 4 array.

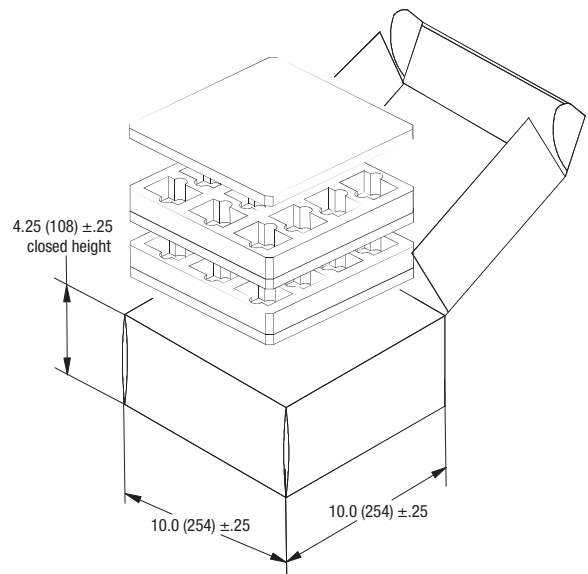

Carton accommodates two (2) trays yielding 24 converters per carton

Dimensions are in inches (mm) shown for ref. only.

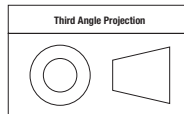

Tolerances (unless otherwise specified):  
 .XX ± 0.02 (0.5)  
 .XXX ± 0.010 (0.25)  
 Angles ± 2'



### TECHNICAL NOTES

#### Power Management Overview

The module includes a wide range of readable and configurable power management features that are easy to implement with a minimum of external components. Furthermore, the module includes protection features that continuously protect the load from damage due to unexpected system faults. The SMBALERT pin alerts the host if there is a fault in the module. The following product parameters can continuously be monitored by a host: Vout, Iout, Vin, Temperature, and Power Good. The module is distributed with a default configuration suitable for a wide range operation in terms of Vin, Vout, and load. All power management functions can be reconfigured using the PMBus interface. The product provides a PMBus digital interface that enables the user to configure many aspects of the device operation as well as monitor the input and output parameters. Please contact our FAE for special configurations.

#### Soft-start Power Up

The default rise time of the ramp up is 20 ms. When starting by applying input voltage the control circuit boot-up time adds an additional 10 ms delay. The soft-start power up of the module can be reconfigured using the PMBus interface.

#### Over Voltage Protection (OVP)

The module includes over voltage limiting circuitry for protection of the load. The default OVP limit is 20% above the nominal output voltage. If the output voltage surpasses the OVP limit, the module can respond in different ways. The default response from an over voltage fault is to immediately shut down. The device will continuously check for the presence of the fault condition, and when the fault condition no longer exists the device will be re-enabled. The OVP fault level and fault response can be reconfigured using the PMBus interface.

#### Over Current Protection (OCP, Current limit)

The module includes current limiting circuitry for protection at continuous over load. The default setting for the product is hicup mode. The current limit could be configured by simply setting the IOUT\_OC\_FAULT\_LIMIT to be greater than the IOUT\_OC\_WARN\_LIMIT. The maximum value that the current limit could be set is 50A.

#### Power Good

The module provides Power Good (PG) flag in the Status Word register that indicates the output voltage is within a specified tolerance of its target level and no fault condition exists. The Power Good pin default logic is negative and it can be configured by MFR\_PGOOD\_POLARITY.

#### PMBus Interface

This module offers a PMBus digital interface that enables the user to configure many characteristics of the device operation as well as to monitor the input and output voltages, output current and device temperature. The module can be used with any standard two-wire I2C or SMBus host device. In addition, the module is compatible with PMBus version 1.2 and includes an SMBALERT line to help alleviate bandwidth limitations related to continuous fault monitoring. The module supports 100 kHz and 400 kHz bus clock frequency only.

#### Monitoring via PMBus

A system controller (host device) can monitor a wide variety of parameters through the PMBus interface. The controller can monitor fault conditions by monitoring the SMBALERT pin, which will be asserted when any number of pre-configured fault or warning conditions occur. The system controller can also continuously monitor any number of power conversion parameters including but not limited to the following:

- Input voltage
- Output voltage
- Output current
- Module temperature

#### Software Tools for Design and Production

For these modules, Murata-PS provides software for configuring and monitoring via the PMBus interface. For more information please contact your local Murata-PS representative.

[Click here for Application Note AN-63, Digital DC-DC Evaluation Board User Guide.](#)

[Click here for Application Note AN-64, Murata Power Brick GUI User Guide.](#)

### PMBus Addressing

Figure 2 and the accompanying table display the recommended resistor values for hard-wiring PMBus addresses (1% tolerance resistors recommended): The address is set in the form of two octal (0 to 7) digits, with each pin setting one digit. The resistor values for each digit is shown below.

The SA0 and SA1 pins can be configured with a resistor to GND according to the following equation.

$$\text{PMBus Address} = 8 \times (\text{SA0value}) + (\text{SA1 value})$$

If the calculated PMBus address is 0d, 11d or 12d, PMBus address 119d is assigned instead. From a system point of view, the user shall also be aware of further limitations of the addresses as stated in the PMBus Specification. It is not recommended to keep the SA0 and SA1 pins left open.

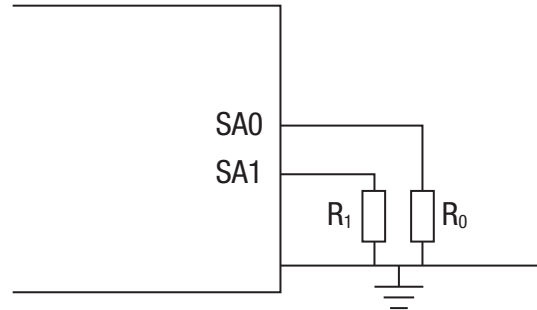

Figure 2. Schematic of Connection of Address Resistors

### PMBus Commands

The products are designed to be PMBus compliant. The following tables list the implemented PMBus read commands. For more detailed information see “PMBus Power System Management Protocol Specification, Part I – General Requirements, Transport and Electrical Interface” and “PMBus Power System Management Protocol, Part II – Command Language.”

Digit (SA0, SA1 index)	Resistor Value [kΩ]
0	10
1	22
2	33
3	47
4	68
5	100
6	150
7	220

### OVERALL

CMD	Command Name	SMBus Transaction Type: Writing Data	SMBus Transaction Type: Reading Data	Number of Data Bytes	Default Value	Lower Limit	Upper Limit	Cross check	Unit
01h	OPERATION <sup>2</sup>	Write Byte	Read Byte	1	0x80				
02h	ON_OFF_CONFIG <sup>3</sup>	Write Byte	Read Byte	1	0x1D				
03h	CLEAR_FAULTS	Send byte	N/A	0	N/A				
10h	WRITE_PROTECT	Write Byte	Read Byte	1	0x00				
11h	STORE_DEFAULT_ALL <sup>4</sup>	Send byte	N/A	0	N/A				
12h	RESTORE_DEFAULT_ALL <sup>4</sup>	Send byte	N/A	0	N/A				
15h	STORE_USER_ALL <sup>4</sup>	Send byte	N/A	0	N/A				
16h	RESTORE_USER_ALL <sup>4</sup>	Send byte	N/A	0	N/A				
19h	CAPABILITY	N/A	Read Byte	1	0xB0				
20h	VOUT_MODE	N/A	Read Byte	1	0x17				
21h	VOUT_COMMAND	Write Word	Read Word	2	12.000	8.100	13.200		V
22h	VOUT_TRIM	Write Word	Read Word	2	0			8.1<=Vout<=13.2 <sup>15</sup>	V
25h	VOUT_MARGIN_HIGH	Write Word	Read Word	2	13.199	8.100	13.199	>VOUT_MARGIN_LOW	V
26h	VOUT_MARGIN_LOW	Write Word	Read Word	2	8.100	8.100	13.200	<VOUT_MARGIN_HIGH	V
28h	VOUT_DROOP	Write Word <sup>12</sup>	Read Word	2	0/12 <sup>13</sup>	0	100	Vout>=8.100	mΩ
40h	VOUT_OV_FAULT_LIMIT	Write Word	Read Word	2	14.199	8.100	15.600	>VOUT_OV_WARN_LIMIT	V
41h	VOUT_OV_FAULT_RESPONSE <sup>5</sup>	Write Byte	Read Byte	1	0xB8				
42h	VOUT_OV_WARN_LIMIT	Write Word	Read Word	2	13.500	8.100	15.600	<VOUT_OV_FAULT_LIMIT >VOUT_COMMAND	V
46h	IOUT_OC_FAULT_LIMIT	Write Word	Read Word	2	59.00	0.00	65.00	>IOUT_OC_WARN_LIMIT	A
47h	IOUT_OC_FAULT_RESPONSE <sup>6</sup>	Write Byte	Read Byte	1	0xF8				
4Ah	IOUT_OC_WARN_LIMIT	Write Word	Read Word	2	56.00	0.00	65.00	<IOUT_OC_FAULT_LIMIT	A
4Fh	OT_FAULT_LIMIT	Write Word	Read Word	2	135	30	145	>OT_WARN_LIMIT	°C
50h	OT_FAULT_RESPONSE <sup>5</sup>	Write Byte	Read Byte	1	0xB8				
51h	OT_WARN_LIMIT	Write Word	Read Word	2	115	30	145	<OT_FAULT_LIMIT	°C
55h	VIN_OV_FAULT_LIMIT	Write Word	Read Word	2	66.50	32.00	110.00	>VIN_OV_WARN_LIMIT	V
56h	VIN_OV_FAULT_RESPONSE <sup>7</sup>	Write Byte	Read Byte	1	0xF8				
57h	VIN_OV_WARN_LIMIT	Write Word	Read Word	2	64.50	32.00	110.00	<VIN_OV_FAULT_LIMIT >VIN_OV_WARN_LIMIT	V
58h	VIN_UV_WARN_LIMIT	Write Word	Read Word	2	42.00	32.00	75.00	<VIN_OV_WARN_LIMIT >VIN_UV_FAULT_LIMIT	V
59h	VIN_UV_FAULT_LIMIT	Write Word	Read Word	2	40.00	32.00	75.00	<VIN_UV_WARN_LIMIT	V
5Ah	VIN_UV_FAULT_RESPONSE <sup>7</sup>	Write Byte	Read Byte	1	0xF8				

### OVERALL (CONT.)

CMD	Command Name	SMBus Transaction Type: Writing Data	SMBus Transaction Type: Reading Data	Number of Data Bytes	Default Value	Lower Limit	Upper Limit	Cross check	Unit
5Eh	POWER_GOOD_ON	Write Word	Read Word	2	10.799	1.000	13.199	>POWER_GOOD_OFF	V
5Fh	POWER_GOOD_OFF	Write Word	Read Word	2	9.600	1.000	13.199	<POWER_GOOD_ON	V
60h	TON_DELAY	Write Word <sup>12</sup>	Read Word	2	1	1	500		ms
61h	TON_RISE <sup>16</sup>	Write Word <sup>12</sup>	Read Word	2	0	10	100		ms
64h	TOFF_DELAY	Write Word <sup>12</sup>	Read Word	2	0	0	500		ms
65h	TOFF_FALL <sup>16</sup>	Write Word <sup>12</sup>	Read Word	2	0	10	100		ms
78h	STATUS_BYTE	Write Byte	Read Byte	1	N/A				
79h	STATUS_WORD	Write Word	Read Word	2	N/A				
7Ah	STATUS_VOUT	Write Byte	Read Byte	1	N/A				
7Bh	STATUS_IOUT	Write Byte	Read Byte	1	N/A				
7Ch	STATUS_INPUT	Write Byte	Read Byte	1	N/A				
7Dh	STATUS_TEMPERATURE	Write Byte	Read Byte	1	N/A				
7Eh	STATUS_CML	Write Byte	Read Byte	1	N/A				
88h	READ_VIN	N/A	Read Word	2	N/A				V
8Bh	READ_VOUT	N/A	Read Word	2	N/A				V
8Ch	READ_IOUT	N/A	Read Word	2	N/A				A
8Dh	READ_TEMPERATURE_1 <sup>8</sup>	N/A	Read Word	2	N/A				°C
8Eh	READ_TEMPERATURE_2 <sup>9</sup>	N/A	Read Word*	2	N/A				°C
94h	READ_DUTY_CYCLE	N/A	Read Word	2	N/A				%
95h	READ_FREQUENCY	N/A	Read Word	2	N/A				KHZ
96h	READ_POUT	N/A	Read Word	2	N/A				W
98h	PMBUS_REVISION	N/A	Read Byte	1	0x42				
99h	MFR_ID	N/A	Block Read	22	"Murata Power Solutions"				
9Ah	MFR_MODEL <sup>10</sup>	Block Write*	Block Read	<=20	N/A				
9Bh	MFR_REVISION <sup>10</sup>	Block Write*	Block Read	<=10	N/A				
9Dh	MFR_DATE <sup>10</sup>	Block Write*	Block Read	<=10	N/A				
9Eh	MFR_SERIAL <sup>10</sup>	Block Write*	Block Read	<=10	N/A				
A0h	MFR_VIN_MIN	N/A	Read Word	2	44.00				V
A1h	MFR_VIN_MAX	N/A	Read Word	2	60.00				V
A2h	MFR_IIN_MAX	N/A	Read Word	2	14.28				A
A3h	MFR_PIN_MAX	N/A	Read Word	2	438				W
A4h	MFR_VOUT_MIN	N/A	Read Word	2	8.100				V
A5h	MFR_VOUT_MAX	N/A	Read Word	2	13.199				V
A6h	MFR_IOUT_MAX	N/A	Read Word	2	50.00				A
A7h	MFR_POUT_MAX	N/A	Read Word	2	600				W
A8h	MFR_TAMBIENT_MAX	N/A	Read Word	2	85				°C
A9h	MFR_TAMBIENT_MIN	N/A	Read Word	2	-40				°C
B0h	USER_DATA_00	Block Write	Block Read	<=20	"..."				
B1h	USER_DATA_01	Block Write	Block Read	<=20	"..."				
C0h	MFR_MAX_TEMP_1	N/A	Read Word	2	135				°C
D0h	MFR_VARIABLE_FREQUENCY_DISABLE	Write Byte	Read Byte	1	0x00				
DBh	MFR_CURRENT_SHARE_CONFIG	Write Byte*	Read Byte	1	0x00/0x01 <sup>11</sup>				
DDh	MFR_PRIMARY_ON_OFF_CONFIG	Write Byte	Read Byte	1	0x04/0x06 <sup>14</sup>				
DEh	MFR_PGOOD_POLARITY	Write Byte	Read Byte	1	0x00				
E8h	MFR_VIN_OV_FAULT_HYS	Write Word	Read Word	2	2.00	1.00	20.00		V
E9h	MFR_VIN_UV_FAULT_HYS	Write Word	Read Word	2	2.00	1.00	20.00		V
EAh	MFR_OT_FAULT_HYS	Write Word	Read Word	2	20	5	50		°C
F6h	MFR_CALIBRATION_STATUS	N/A	Read Byte*	1	0xC7				
F9h	MFR_VIN_SENSE_CALIBRATION	Write byte*	N/A	1	N/A				
FAh	MFR_IOUT_SENSE_CALIBRATION	Write Word*	N/A	2	N/A				
FBh	MFR_VOUT_SET_POINT_CALIBRATION	Write Word*	N/A	2	N/A				
FCh	MFR_SUPERVISOR_PASSWORD	Block Write	N/A	N/A	N/A				

### OVERALL (CONT.)

#### Notes:

- \* Only available in supervisor mode (default state is user mode, send password to comand 0xFC to change to supervisor mode)
- 1. a) Unit restores the entire contents of the non-volatile User Store memory when power up
  - b) PEC is supported
  - c) Max bus speed: 400kHz
  - d) SMBALERT# is supported
  - e) Linear data format used
  - f) addressing: If the calculated PMBus address is 0d, 11d or 12d, SA0 or SA1 lefts open, default PMBus address 120d is assigned instead.
- 2. Not supported items:
  - 100101XXb Margin Low(Ignore Fault),
  - 101001XXb On Margin High(Ignore Fault)
- 3. Restart delay of turned off by OPEATION or CONTROL or primary on/off is 200ms
- 4. Unit will shutdown 1 second for protection , then recover automaticly
- 5. Restart delay unit: 500ms, lower limit: 500ms.
  - Turn off delay unit: 0ms, lower limit: 0ms
  - if bits 7:6=11b, restart delay is 500ms
- 6. Restart delay unit and Turn off delay unit are same as note 5
  - Bits 7:6: 00b,01b,10b are not supported
- 7. Restart delay unit: 100ms, lower limit: 100ms.
  - Turn off delay unit:0ms, lower limit: 0ms if bits 7:6=11b, restart delay is 100ms
- 8. Temperature of baseplate side
- 9. Temperature of pin side
- 10. Unit's actual inforamtion
- 11. Default value of DROOP CURRENT SHARE mode: 0x01
  - Default value of CURRENT SHARE DISABLED mode: 0x00
- 12. Not available in Droop current share mode
- 13. Locked to 12mΩ in DROOP CURRENT SHARE mode; configurable and default value is 0mΩ in CURRENT SHARE DISABLED mode
- 14. Default value of negative logic: 0x04
  - Default value of positive logic: 0x06
- 15. Unit can receive any value for VOUT\_TRIM command, but Vout is limited to 8.1~13.2V, if calculated Vout exceeds limit, then equal to limit.
- 16. Value of 0 is acceptable, which is the same as lower limit to unit.

### MURATA-PS defined commands (01-CFh Refer to PMBus 1.2 SPEC)

D0h: MFR_VARIABLE_FREQUENCY_DISABLE			
Bits	Purpose	Value	Meaning
7:1		0000000	Reserved
0	Variable frequency control	0	Turn on variable frequency control
		1	Turn off variable frequency control

DBh: MFR_CURRENT_SHARE_CONFIG				CTRL/CS Pin	VOUT_DROOP	TON_DELAY	TOFF_DELAY	TON_RISE	TOFF_FALL
Bits	Purpose	Value	Meaning						
7:1		0000000	Reserved	--	--	--	--	--	--
0	Droop Current Share Control	0	Current share disabled	CTRL	configurable	configurable	configurable	configurable	configurable
		1	Droop current share mode enabled	CTRL	locked to 0x000A	locked to 0x0001	locked to 0x0000	locked to 0x0000	locked to 0x0000

DDh: MFR_PRIMARY_ON_OFF_CONFIG			
Bits	Purpose	Value	Meaning
7:3		00000	Reserved
2	Controls how the unit responds to the CONTROL pin	0	Unit ignores the primary ON/OFF pin
		1	Unit requires the primary ON/OFF pin to be asserted to start the unit.
1	Polarity of primary ON/OFF logic	0	Active low (Pull pin low to start the unit)
		1	Active high (Pull high or open to start the unit)
0		0	Reserved

DEh: MFR_PGOOD_POLARITY			
Bits	Purpose	Value	Meaning
7:1		0000000	Reserved
0	Power good polarity of pin 12	0	Negative logic, output low if Vout rises to specific value
		1	Positive logic, output high if Vout rises to specific value

E8h: MFR_VIN_OV_FAULT_HYS
Hysteresis of VIN_OV_FAULT recover, Linear data format

E9h: MFR_VIN_UV_FAULT_HYS
Hysteresis of VIN_UV_FAULT recover, Linear data format

EAh: MFR_OT_FAULT_HYS
Hysteresis of OT_FAULT recover, Linear data format

F6h: MFR_CALIBRATION_STATUS
Refer to calibration procedure file

F9h: MFR_VIN_SENSE_CALIBRATION
Refer to calibration procedure file

FAh: MFR_IOUT_SENSE_CALIBRATION
Refer to calibration procedure file

FBh: MFR_VOUT_SET_POINT_CALIBRATION
Refer to calibration procedure file

FCh: MFR_SUPERVISOR_PASSWORD
Set unit to supervisor mode or ROM mode, Refer to password table

**STATUS WORD AND BYTE (GREEN = SUPPORTED)**

STATUS_VOUT	
7	VOUT_OV_FAULT
6	VOUT_OV_WARNING
5	VOUT_UV_WARNING
4	VOUT_UV_FAULT
3	VOUT_MAX Warning
2	TON_MAX_FAULT
1	TOFF_MAX_WARNING
0	VOUT Tracking Error

STATUS_IOUT	
7	IOUT_OC_FAULT
6	IOUT_OC_LV_FAULT
5	IOUT_OC_WARNING
4	IOUT_UC_FAULT
3	Current Share Fault
2	In Power Limiting Mode
1	POUT_OP_FAULT
0	POUT_OP_WARNING

STATUS_TEMPERATURE	
7	OT_FAULT
6	OT_WARNING
5	UT_WARNING
4	UT_FAULT
3	Reserved
2	Reserved
1	Reserved
0	Reserved

STATUS_CML	
7	Invalid/Unsupported Command
6	Invalid/Unsupported Data
5	Packet Error Check Failed
4	Memory Fault Detected
3	Processor Fault Detected
2	Reserved
1	Other Communication Fault
0	Other Memory Or Logic Fault

STATUS_WORD	
7	VOUT
6	IOUT/POUT
5	INPUT
4	MFR_SPECIFIC
3	POWER_GOOD#
2	FANS
1	OTHER
0	UNKNOWN
7	BUSY
6	OFF
5	VOUT_OV_FAULT
4	IOUT_OC_FAULT
3	VIN_UV_FAULT
2	TEMPERATURE
1	CML
0	NONE OF THE ABOVE

STATUS_OTHER	
7	Reserved
6	Reserved
5	Input A Fuse/Breaker Fault
4	Input B Fuse/Breaker Fault
3	Input A OR-ing Device Fault
2	Input B OR-ing Device Fault
1	Output OR-ing Device Fault
0	Reserved

STATUS_INPUT	
7	VIN_OV_FAULT
6	VIN_OV_WARNING
5	VIN_UV_WARNING
4	VIN_UV_FAULT
3	Unit Off For Low Input Voltage
2	IIN_OC_FAULT
1	IIN_OC_WARNING
0	PIN_OP_WARNING

STATUS_MFR_SPECIFIC	
	Manufacturer Defined
	Manufacturer Defined
	Manufacturer Defined
	Manufacturer Defined
	Manufacturer Defined
	Manufacturer Defined
	Manufacturer Defined
	Manufacturer Defined

STATUS_FANS_1_2	
7	Fan 1 Fault
6	Fan 2 Fault
5	Fan 1 Warning
4	Fan 2 Warning
3	Fan 1 Speed Override
2	Fan 2 Speed Override
1	Air Flow Fault
0	Air Flow Warning

STATUS_FANS_3_4	
7	Fan 3 Fault
6	Fan 4 Fault
5	Fan 3 Warning
4	Fan 4 Warning
3	Fan 3 Speed Override
2	Fan 4 Speed Override
1	Reserved
0	Reserved

### TECHNICAL NOTES (CONT.)

#### Parallel Load Sharing (S Option, Load Sharing)

Two or more converters may be connected in parallel at both the input and output terminals to support higher output current (total power, see figure 3) or to improve reliability due to the reduced stress that results when the modules are operating below their rated limits. For applications requiring current share, followed the guidelines below. The products have a pre-configured voltage. The stated output voltage set point is at no load. The output voltage will decrease when the load current is increased. The voltage will drop 0.35V while load reaches max load. Our goal is to have each converter contribute nearly identical current into the output load under all input, environmental and load conditions.

#### Using Parallel Connections – Load Sharing (Power Boost)

Direct Connection Parallel Guidelines

- Use a common input power source. The input voltage must be between 44V and 60V.
- +Vout and –Vout of all parallel units should be connected with a balance output impedance; +Sense and –Sense should be connected together with PMBus option (see figure 3).
- Turn all units off before configuring the output voltage via PMBus commands; all units must have the same output voltage configuration.
- It is recommended to turn on one unit first and then turn other unit (s) on after the output for the first one has settled. Turn on the next unit (s) after the previous unit reaches its regulated output voltage for at least 10mS. Users can use a different control signal to turn each unit on.
- Users have the option to use a common primary or secondary Remote On/Off logic control signal to turn on modules at the same time after the input voltage rises above 44V.
- Do not use PMBus to control unit On/Off when parallel operation is used.
- First power up the parallel system (all converters) with a load not exceeding the rated load of  $60\% * 50A * UNITS\_QUANTITY$  and allow converters to settle (typically 10-50mS) before applying full load (90% load is recommended). If the loads are downstream POL converters, power these up shortly after the converter has reached steady state output. Also be aware of the delay caused by charging up external bypass capacitors.
- When converters are connected in parallel, allow for a safety factor of at least 10%. Up to 90% of max output current can be used from each module.
- It is critical that the PCB layout incorporates identical connections from each module to the load; use the same trace rating and airflow/thermal environments. If you add input filter components, use identical components and layout.
- For Power-down, do not soft-off (GUI) while in parallel operation. Power down units by primary or secondary On/Off signal. Turn units off at the same time or one by one to avoid the OCP being triggered.

**CAUTION:** This converter is not internally fused. To avoid danger to persons or equipment and to retain safety certification, the user must connect an external fast-blow input fuse as listed in the specifications. Be sure that the PCB board pad area and etch size are adequate to provide enough current so that the fuse will blow with an overload.

#### Using Parallel Connections – Redundancy (N+1)

The redundancy connections require external user supplied “OR”ing diodes or “OR”ing MOSFETs for reliability purposes. The diodes allow for an uninterrupted power system operation in case of a catastrophic failure (shorted output) by one of the converters.

The diodes should be identical part numbers to enhance balance between the converters. The default factory nominal voltage should be sufficiently matched between converters. The OR’ing diode system is the responsibility of the user. Be aware of the power levels applied to the diodes and possible heat sink requirements.

Schottky power diodes with approximately 0.3V drops or “OR”ing MOSFETs may be suitable in the loop whereas 0.7 V silicon power diodes may not be advisable. In the event of an internal device fault or failure of the mains power modules on the primary side, the other devices automatically take over the entire supply of the loads. In the basic N+1 power system, the “N” equals the number of modules required to fully power the system and “+1” equals one back-up module that will take over for a failed module. If the system consists of two power modules, each providing 50% of the total load power under normal operation and one module fails, another one delivers full power to the load. This means you can use smaller and less expensive power converters as the redundant elements, while achieving the goal of increased availability.

#### Thermal Shutdown

Extended operation at excessive temperature will initiate overtemperature shutdown triggered by a temperature sensor outside the PWM controller. This operates similarly to overcurrent and short circuit mode. The inception point of the overtemperature condition depends on the average power delivered, the ambient temperature and the extent of forced cooling airflow. Thermal shutdown uses only the hiccup mode (autorestart) and PMBus configurable hysteresis.

#### Start Up Considerations

When power is first applied to the DC-DC converter, there is some risk of start up difficulties if you do not have both low AC and DC impedance and adequate regulation of the input source. Make sure that your source supply does not allow the instantaneous input voltage to go below the minimum voltage at all times.

Use a moderate size capacitor very close to the input terminals. You may need two or more parallel capacitors. A larger electrolytic or ceramic cap supplies the surge current and a smaller parallel low-ESR ceramic cap gives low AC impedance.

Remember that the input current is carried both by the wiring and the ground plane return. Make sure the ground plane uses adequate thickness copper. Run additional bus wire if necessary.

#### Input Fusing

Certain applications and/or safety agencies may require fuses at the inputs of power conversion components. Fuses should also be used when there is the possibility of sustained input voltage reversal which is not current-limited. For greatest safety, we recommend a fast blow fuse installed in the ungrounded input supply line.

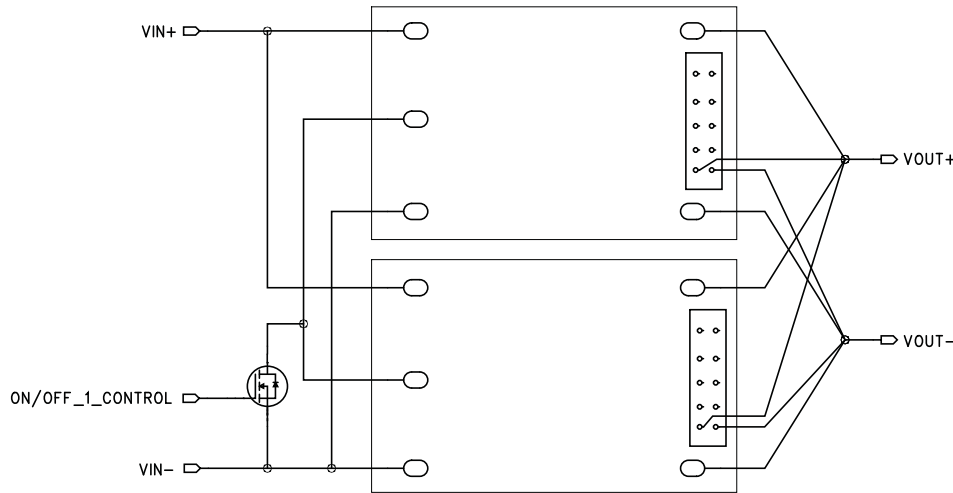

Figure 3. Load Sharing Block Diagram

### Input Under-Voltage Shutdown and Start-Up Threshold

Converters will not begin to regulate properly until the rising input voltage exceeds and remains at the Start-Up Threshold Voltage (see Specifications). Once operating, converters will not turn off until the input voltage drops below the Under-Voltage Shutdown Limit. Subsequent restart will not occur until the input voltage rises again above the Start-Up Threshold. This built-in hysteresis prevents any unstable on/off operation at a single input voltage. The over/under-voltage fault level and fault response and hysteresis can be configured via the PMBus interface.

### Start-Up Time

Start-Up Time (see Specifications) is the time interval between the point when the rising input voltage crosses the Start-Up Threshold and the output voltage enters and remains within its specified accuracy band.

These converters include a soft start circuit to control Vout ramp time, thereby limiting the input inrush current.

The On/Off Remote Control interval from On command to Vout (final  $\pm 5\%$ ) assumes that the converter already has its input voltage stabilized above the Start-Up Threshold before the On command. The interval is measured from the On command until the output enters and remains within its specified accuracy band.

### Recommended Input Filtering

The user must assure that the input source has low AC impedance to provide dynamic stability and that the input supply has little or no inductive content, including long distributed wiring to a remote power supply. The converter will operate with no additional external capacitance if these conditions are met.

For best performance, we recommend installing a low-ESR capacitor immediately adjacent to the converter's input terminals. The capacitor should be a ceramic type such as the Murata GRM32 series or a polymer type. More input bulk capacitance may be added in parallel (either electrolytic or tantalum) if needed.

### Recommended Output Filtering

The converter will achieve its rated output ripple and noise with no additional external capacitor. However, the user may install more external output capacitance to reduce the ripple even further or for improved dynamic response. Again, use low-ESR ceramic (Murata GRM32 series) or polymer capacitors. Mount these close to the converter. Measure the output ripple under your load conditions.

Use only as much capacitance as required to achieve your ripple and noise objectives. Excessive capacitance can make step load recovery sluggish or possibly introduce instability. Do not exceed the maximum rated output capacitance listed in the specifications.

### Input Ripple Current and Output Noise

All models in this converter series are tested and specified for input reflected ripple current and output noise using designated external input/output components, circuits and layout as shown in the figures below. The Cbus and Lbus components simulate a typical DC voltage bus.

### Minimum Output Loading Requirements

All models regulate within specification and are stable under no load to full load conditions.

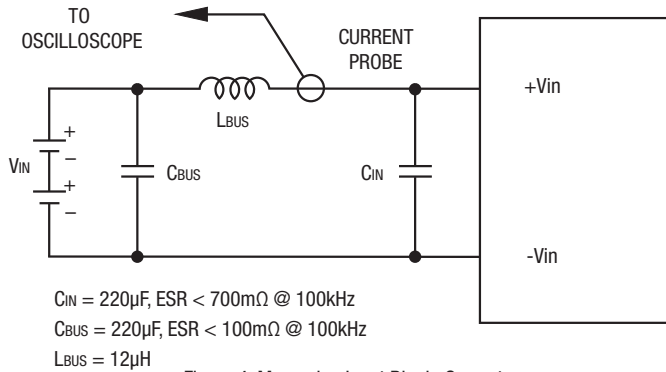

Figure 4. Measuring Input Ripple Current

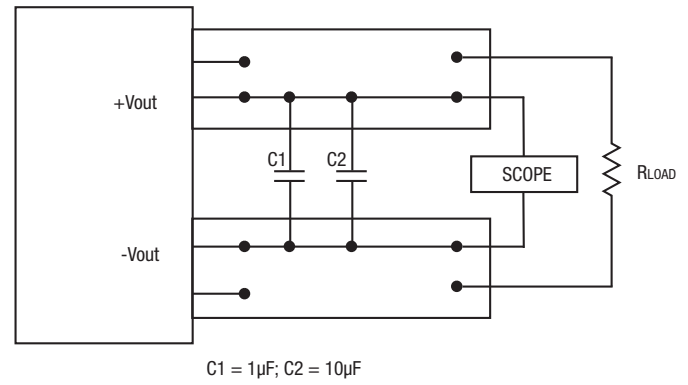

Figure 5. Measuring Output Ripple and Noise (PARD)

### Thermal Shutdown (OTP, UTP)

To prevent many over temperature problems and damage, these converters include thermal shutdown circuitry. If environmental conditions cause the temperature of the DC-DCs to rise above the Operating Temperature Range up to the shutdown temperature, an on-board electronic temperature sensor will power down the unit. When the temperature decreases below the turn-on threshold set in the command recover temp is (OT\_FAULT\_LIMIT-MFR\_OT\_FAULT\_HYS), the hysteresis is defined in general electrical specification section. The OTP and hysteresis of the module can be reconfigured using the PMBus. The OTP and UTP fault limit and fault response can be configured via the PMBus.

**CAUTION:** If you operate too close to the thermal limits, the converter may shut down suddenly without warning. Be sure to thoroughly test your application to avoid unplanned thermal shutdown.

### Temperature Derating Curves

The graphs in this data sheet illustrate typical operation under a variety of conditions. The Derating curves show the maximum continuous ambient air temperature and decreasing maximum output current which is acceptable under increasing forced airflow measured in Linear Feet per Minute (“LFM”). Note that these are AVERAGE measurements. The converter will accept brief increases in current or reduced airflow as long as the average is not exceeded.

Note that the temperatures are of the ambient airflow, not the converter itself which is obviously running at higher temperature than the outside air. Also note that “natural convection” is defined as very low rates which are not using fan-forced airflow. Depending on the application, “natural convection” is usually about 30-65 LFM but is not equal to still air (0 LFM).

Murata Power Solutions makes Characterization measurements in a closed cycle wind tunnel with calibrated airflow. We use both thermocouples and an infrared camera system to observe thermal performance. As a practical matter, it is quite difficult to insert an anemometer to precisely measure airflow in most applications. Sometimes it is possible to estimate the effective airflow if you thoroughly understand the enclosure geometry, entry/exit orifice areas and the fan flowrate specifications.

**CAUTION:** If you exceed these Derating guidelines, the converter may have an unplanned Over Temperature shut down. Also, these graphs are all collected near Sea Level altitude. Be sure to reduce the derating for higher altitude.

### Output Short Circuit Condition

The short circuit condition is an extension of the “Current Limiting” condition. When the monitored peak current signal reaches a certain range, the PWM controller’s outputs are shut off thereby turning the converter “off.” This is followed by an extended time out period. This period can vary depending on other conditions such as the input voltage level. Following this time out period, the PWM controller will attempt to re-start the converter by initiating a “normal start cycle” which includes softstart. If the “fault condition” persists, another “hiccup” cycle is initiated. This “cycle” can and will continue indefinitely until such time as the “fault condition” is removed, at which time the converter will resume “normal operation.” Operating in the “hiccup” mode during a fault condition is advantageous in that average input and output power levels are held low preventing excessive internal increases in temperature.

### Remote On/Off Control

The DRQ series modules are equipped with both primary (On/Off 1, enabled, pull up internal) and secondary (On/Off 2, disabled, pull up internal) control pins for increased system flexibility. Both are configurable via PMBus. The On/Off pins are TTL open-collector and/or CMOS open-drain compatible. (See general specifications for threshold voltage levels. See also MFR\_PRIMARY\_ON\_OFF\_CONFIG section.)

**Negative-logic** models are on (enabled) when the On/Off is grounded or brought to within a low voltage (see specifications) with respect to  $-V_{in}$ . The device is off (disabled) when the On/Off is left open or is pulled high to +13.5Vdc with respect to  $-V_{in}$ . The On/Off function allows the module to be turned on/off by an external device switch.

**Positive-logic** models are enabled when the On/Off pin is left open or is pulled high to +13.5V with respect to  $-V_{in}$ . Positive-logic devices are disabled when the On/Off is grounded or brought to within a low voltage (see specifications) with respect to  $-V_{in}$ . For voltage levels for On/Off 2 signal see functional specifications.

The restart delay for this module to turn On/Off by the On/Off control pin is 100ms.

On/Off 1 or 2 Control status	Not ignored		Ignored	
	P LOGIC	N LOGIC	P LOGIC	N LOGIC
OPEN	ON	OFF	ON	ON
PULL HIGH	ON	OFF	ON	ON
PULL LOW	OFF	ON	ON	ON



On/Off 1 can be configured by PMBus command MFR\_PRIMARY\_ON\_OFF\_CONFIG (DDh); default configuration is not ignored; required On/Off 1 control pin to be asserted to start the unit.

On/Off 2 can be configured by PMBUS command ON\_OFF\_CONFIG (02h); default configuration is ignored; treat it as always ON.

DRQ's On/Off status is dependent on On/Off 1 control, On/Off 2 control, and OPERATION (PMBus command) status; all three must be ON to turn DRQ on; if one of them is OFF, unit will be turned off.

### Output Capacitive Load

These converters do not require external capacitance added to achieve rated specifications. Users should only consider adding capacitance to reduce switching noise and/or to handle spike current load steps. Install only enough capacitance to achieve noise objectives. Excess external capacitance may cause degraded transient response and possible oscillation or instability.

### Remote Sense Input

Use the Sense inputs with caution. Sense is normally connected **at the load**. Sense inputs compensate for output voltage inaccuracy delivered at the load.

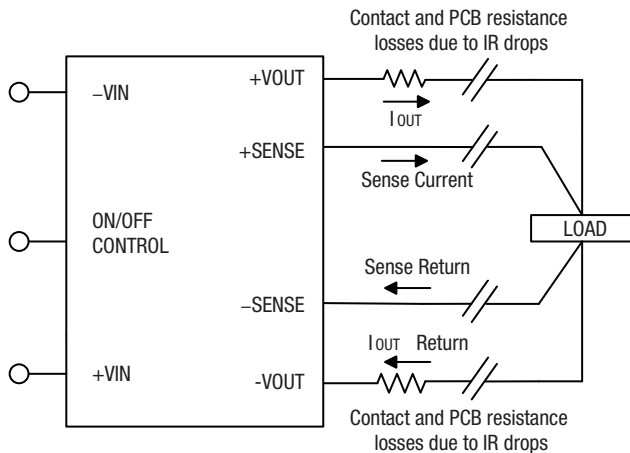

Figure 6. Remote Sense Circuit Configuration

This is done by correcting IR voltage drops along the output wiring and the current carrying capacity of PC board etc. This output drop (the difference between Sense and Vout when measured at the converter) should not exceed 0.5V. Consider using heavier wire if this drop is excessive. Sense inputs also improve the stability of the converter and load system by optimizing the control loop phase margin.

Note: The Sense input and power Vout lines are internally connected through low value resistors to their respective polarities so that the converter can operate without external connection to the Sense. Nevertheless, if the Sense function is not used for remote regulation, the user should connect +Sense to +Vout and -Sense to -Vout at the converter pins.

The remote Sense lines carry very little current. They are also capacitively coupled to the output lines and therefore are in the feedback control loop to regulate and stabilize the output. As such, they are not low impedance inputs and must be treated with care in PC board layouts. Sense lines on the PCB should run adjacent to DC signals, preferably Ground. In cables and discrete wiring, use twisted pair, shielded tubing or similar techniques.

Any long, distributed wiring and/or significant inductance introduced into the Sense control loop can adversely affect overall system stability. If in doubt, test your applications by observing the converter's output transient response during step loads. There should not be any appreciable ringing or oscillation. You may also adjust the output trim slightly to compensate for voltage loss in any external filter elements. Do not exceed maximum power ratings.

Please observe Sense inputs tolerance to avoid improper operation:

$$[V_{out(+)} - V_{out(-)}] - [Sense(+)] - Sense(-)] \leq 10\% \text{ of } V_{out}$$

Output overvoltage protection is monitored at the output voltage pin, not the Sense pin. Therefore excessive voltage differences between Vout and Sense together with trim adjustment of the output can cause the overvoltage protection circuit to activate and shut down the output.

Power derating of the converter is based on the combination of maximum output current and the highest output voltage. Therefore the designer must ensure:

$$(V_{out \text{ at pins}}) \times (I_{out}) \leq (\text{Max. rated output power})$$

### Soldering Guidelines

Murata Power Solutions recommends the specifications below when installing these converters. These specifications vary depending on the solder type. Exceeding these specifications may cause damage to the product. Be cautious when there is high atmospheric humidity. We strongly recommend a mild pre-bake (100° C. for 30 minutes). Your production environment may differ; therefore please thoroughly review these guidelines with your process engineers.

Wave Solder Operations for through-hole mounted products (THMT)	
<b>For Sn/Ag/Cu based solders:</b>	
Maximum Preheat Temperature	115° C.
Maximum Pot Temperature	270° C.
Maximum Solder Dwell Time	7 seconds
<b>For Sn/Pb based solders:</b>	
Maximum Preheat Temperature	105° C.
Maximum Pot Temperature	250° C.
Maximum Solder Dwell Time	6 seconds

### Emissions Performance

Murata Power Solutions measures its products for conducted emissions against the EN 55022 and CISPR 22 standards. Passive resistance loads are employed and the output is set to the maximum voltage. If you set up your own emissions testing, make sure the output load is rated at continuous power while doing the tests.

The recommended external input and output capacitors (if required) are included. Please refer to the fundamental switching frequency. All of this information is listed in the Product Specifications. An external discrete filter is installed and the circuit diagram is shown below.

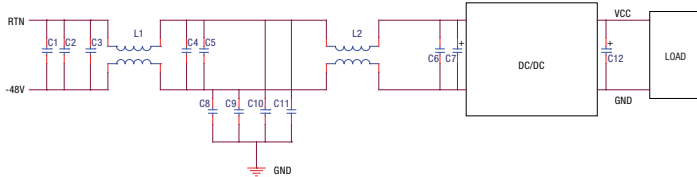

Figure 7. Conducted Emissions Test Circuit

### [1] Conducted Emissions Parts List

Reference	Part Number	Description	Vendor
C1, C2, C3, C4, C5	GRM32ER72A105KA01L	SMD CERAMIC-100V-1000nF-X7R-1210	Murata
C6	GRM319R72A104KA01D	SMD CERAMIC100V-100nF-±10%-X7R-1206	Murata
L1, L2	PG0060T	COMMON MODE-473uH-±25%-14A	Pulse
C8, C9, C10, C11	GRM55DR72J224KW01L	SMD CERAMIC630V-0.22uF-±10%-X7R-2220	Murata
C7	UHE2A221MHD	Aluminum100V-220uF-±10%-long lead	Nichicon
C12	NA		

### [2] Conducted Emissions Test Equipment Used

Hewlett Packard HP8594L Spectrum Analyzer – S/N 3827A00153  
2Line V-networks LS1-15V 50Ω/50uH Line Impedance Stabilization Network

### [3] Conducted Emissions Test Results

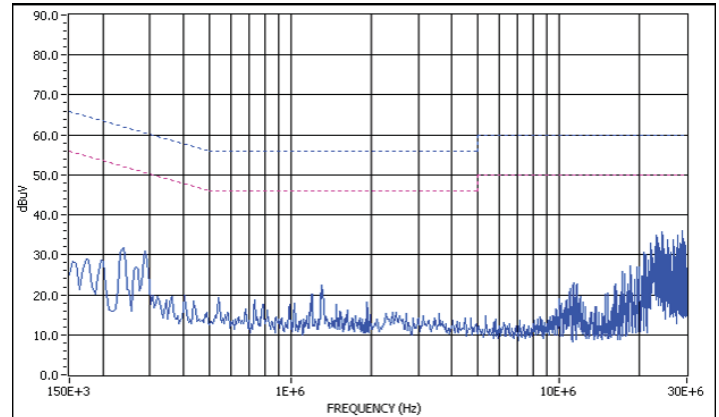

Graph 1. Conducted emissions performance, Positive Line, CISPR 22, Class B, full load

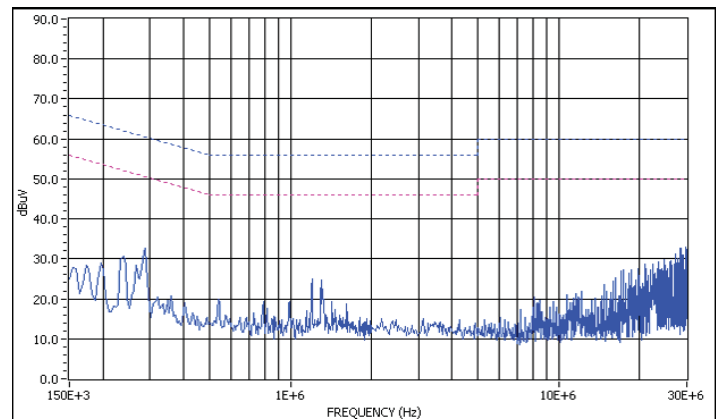

Graph 2. Conducted emissions performance, Negative Line, CISPR 22, Class B, full load

### [4] Layout Recommendations

Most applications can use the filtering which is already installed inside the converter or with the addition of the recommended external capacitors. For greater emissions suppression, consider additional filter components and/or shielding. Emissions performance will depend on the user's PC board layout, the chassis shielding environment and choice of external components. Please refer to Application Note GEAN-02 for further discussion.

Since many factors affect both the amplitude and spectra of emissions, we recommend using an engineer who is experienced at emissions suppression.