



Chipsmall Limited consists of a professional team with an average of over 10 year of expertise in the distribution of electronic components. Based in Hongkong, we have already established firm and mutual-benefit business relationships with customers from,Europe,America and south Asia,supplying obsolete and hard-to-find components to meet their specific needs.

With the principle of “Quality Parts,Customers Priority,Honest Operation,and Considerate Service”,our business mainly focus on the distribution of electronic components. Line cards we deal with include Microchip,ALPS,ROHM,Xilinx,Pulse,ON,Everlight and Freescale. Main products comprise IC,Modules,Potentiometer,IC Socket,Relay,Connector.Our parts cover such applications as commercial,industrial, and automotives areas.

We are looking forward to setting up business relationship with you and hope to provide you with the best service and solution. Let us make a better world for our industry!



## Contact us

Tel: +86-755-8981 8866 Fax: +86-755-8427 6832

Email & Skype: info@chipsmall.com Web: www.chipsmall.com

Address: A1208, Overseas Decoration Building, #122 Zhenhua RD., Futian, Shenzhen, China



**DALLAS**  
SEMICONDUCTOR

## DS2105 SCSI Terminator

### FEATURES

- Fully compliant with SCSI-1, Fast SCSI and Ultra SCSI
- Functionally compatible to the DS21S07A, targeted for high volume applications
- Provides active termination for nine signal lines
- Laser-trimmed 110 ohm termination resistors have 5% tolerance
- Low dropout voltage
- Power-down mode isolates termination resistors from the bus
- Fully supports actively negated SCSI signals
- Onboard thermal shutdown circuitry
- 16-pin plastic SOIC (DS2105)

### DESCRIPTION

Fast SCSI and Ultra SCSI require the use of active terminations at both ends of every cable segment in a SCSI system with single-ended drivers and receivers. The DS2105 SCSI Terminator, which is fully compliant with these standards, enables the designer to gain the benefits of active termination: greater immunity to voltage drops on the TERMPWR (TERMination PoWeR) line, enhanced high-level noise immunity, intrinsic TERMPWR decoupling, and very low quiescent current

### PIN ASSIGNMENT

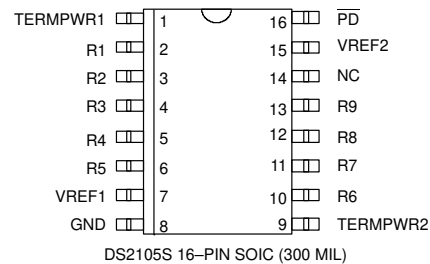
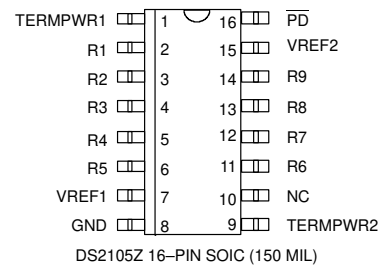

consumption. The DS2105, which integrates a regulator and nine precise switched 110 ohm termination resistors into a monolithic IC, is a functionally compatible version of the DS21S07A. With relaxed output current and termination tolerances, the DS2105 is intended for high volume applications which require active termination but not the high performance of the DS21S07A. The DS2105 is offered in both 300 mil and 150 mil SOIC packages.

### FUNCTIONAL DESCRIPTION

The DS2105 consists of a bandgap reference, buffer amplifier, and nine termination resistors (Figure 1). The bandgap reference circuit produces a precise 2.55V level which is fed to a buffer amplifier. The buffer produces a 2.85V level and is capable of sourcing at least 24 mA into each of the termination resistors when the signal line is low (active). When the driver for a given signal line turns off, the terminator will pull the signal line to 2.85V (quiescent state). To handle actively negated SCSI signals, the buffer can sink 200 mA, and  $V_{REF}$  will move less than 60 mV. When all lines settle in the quiescent state, the regulator will consume about 5 mA. When the DS2105 is put into power-down mode by bringing  $\overline{PD}$  low, the power-down circuitry will turn off the transistors on each signal line. This will isolate the DS2105 from the signal lines and effectively remove it

from the circuit. The power-down pin ( $\overline{PD}$ ) has an internal 50K $\Omega$  pull-up resistor. To place the DS2105 into an active state, the  $\overline{PD}$  pin should be left open circuited.

To ensure proper operation, both the TERMPWR1 and TERMPWR2 pins must be connected to the SCSI bus TERMPWR line and both the VREF1 and VREF2 pins must be tied together externally. Each DS2105 requires a 4.7  $\mu$ F capacitor connected between the VREF pins and ground. Figure 2 details a typical SCSI bus configuration. In an 8-bit wide SCSI bus arrangement ("A" Cable), two DS2105's would be needed at each end of the SCSI cable in order to terminate the 18 active signal lines. In a 16-bit wide SCSI bus arrangement ("P" Cable), three DS2105's would be needed at each end of the SCSI cable in order to terminate the 27 active signal lines.

**DS2105 BLOCK DIAGRAM** Figure 1

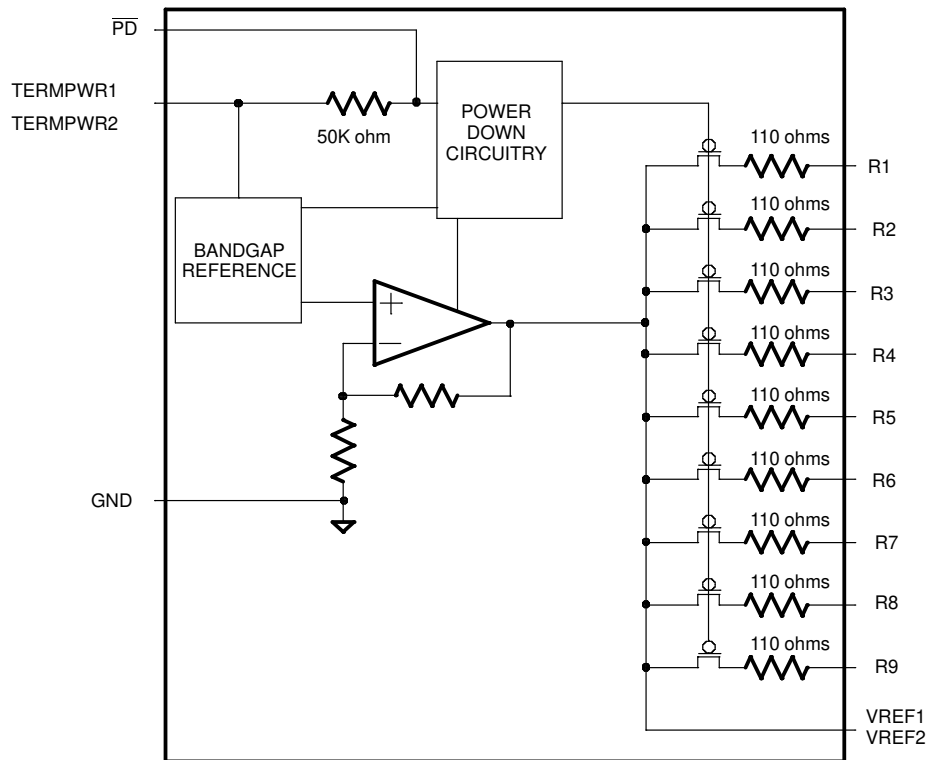

TYPICAL SCSI BUS CONFIGURATION Figure 2

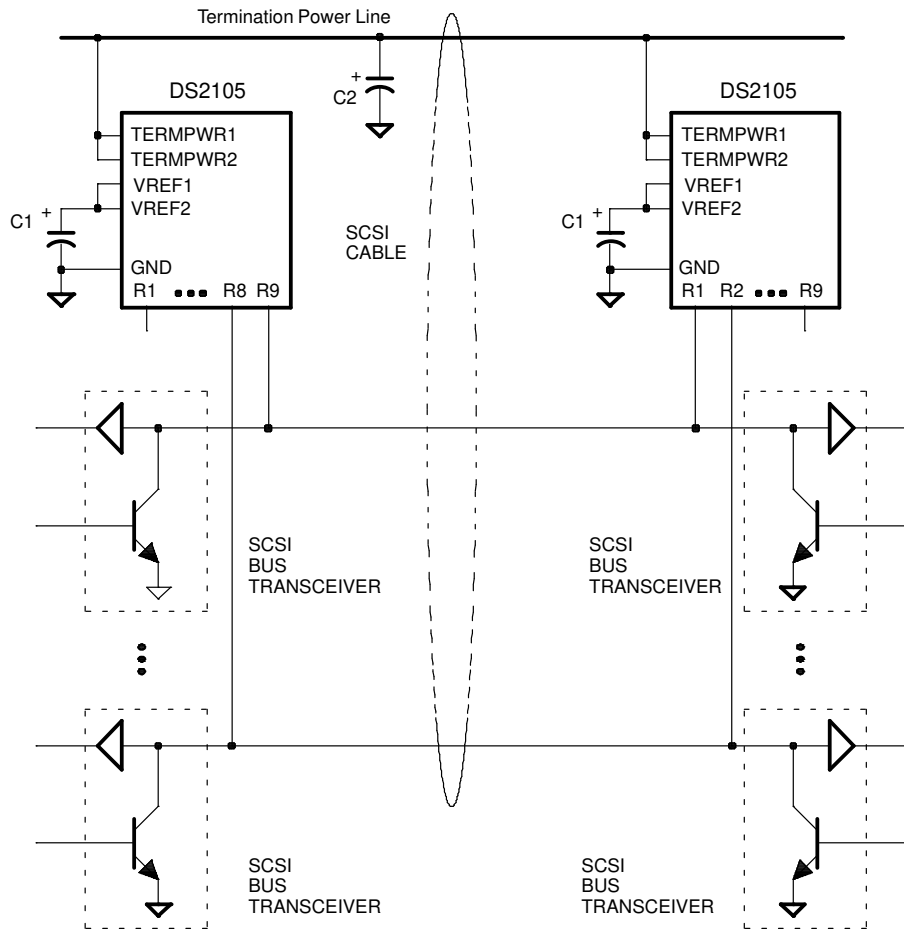
**NOTES:**

1. C1 = 4.7  $\mu$ F tantalum  
C2 = 2.2  $\mu$ F tantalum or 4.7  $\mu$ F aluminum
2. If the DS2105 is to be embedded into a peripheral that will act as a target on a SCSI bus, it is recommended that TERMPWR be derived from the SCSI cable, not generated locally. In this configuration, if a power failure occurs in the peripheral, it will not affect the bus.
3. A high frequency bypass capacitor (0.1  $\mu$ F recommended) can be added in parallel to C1 for applications using fast rise/fall time drivers.

**PIN DESCRIPTION** Table 1

DS2105S PIN	DS2105Z PIN	SYMBOL	DESCRIPTION
1	1	TERMPWR1	<b>Termination Power 1.</b> Should be connected to the SCSI TERMPWR line. Must be decoupled with either a 2.2 $\mu$ F or 4.7 $\mu$ F. See Figure 2.
2	2	R1	<b>Signal Termination 1.</b> 110 ohm termination.
3	3	R2	<b>Signal Termination 2.</b> 110 ohm termination.
4	4	R3	<b>Signal Termination 3.</b> 110 ohm termination.
5	5	R4	<b>Signal Termination 4.</b> 110 ohm termination.
6	6	R5	<b>Signal Termination 5.</b> 110 ohm termination.
7	7	VREF1	<b>Reference Voltage 1.</b> Must be externally connected directly to the VREF2 pin. Must be decoupled with a 4.7 $\mu$ F capacitor as shown in Figure 2.
8	8	GND	<b>Ground.</b> Signal ground; 0.0V.
9	9	TERMPWR2	<b>Termination Power 2.</b> Should be connected to the SCSI TERMPWR line. Must be decoupled with either a 2.2 $\mu$ F or 4.7 $\mu$ F. See Figure 2.
10	11	R6	<b>Signal Termination 6.</b> 110 ohm termination.
11	12	R7	<b>Signal Termination 7.</b> 110 ohm termination.
12	13	R8	<b>Signal Termination 8.</b> 110 ohm termination.
13	14	R9	<b>Signal Termination 9.</b> 110 ohm termination.
15	15	VREF2	<b>Reference Voltage 2.</b> Must be externally connected directly to the VREF1 pin. Must be decoupled with a 4.7 $\mu$ F capacitor as shown in Figure 2.
16	16	$\overline{\text{PD}}$	<b>Power Down.</b> When tied low, the DS2105 enters a power-down mode. Contains an internal 50K pull-up. Strap low to deactivate the DS2105, leave open circuited to activate the DS2105.
14	10	NC	<b>No Connect.</b> Do not connect any signal to this pin.

**ABSOLUTE MAXIMUM RATINGS\***

Voltage on Any Pin Relative to Ground	-1.0V to +7.0V
Operating Temperature	0°C to 70°C
Storage Temperature	-55°C to +125°C
Soldering Temperature	260°C for 10 seconds

\* This is a stress rating only and functional operation of the device at these or any other conditions above those indicated in the operation sections of this specification is not implied. Exposure to absolute maximum rating conditions for extended periods of time may affect reliability.

**RECOMMENDED OPERATING CONDITIONS**

(0°C to 70°C)

PARAMETER	SYMBOL	MIN	TYP	MAX	UNITS	NOTES
TERMPWR Voltage	$V_{TP}$	4.00		5.25	V	
$\overline{PD}$ Active	$V_{PDA}$	-0.3		+0.8	V	
$\overline{PD}$ Inactive	$V_{PDI}$	2.0		$V_{TP} + 0.3$	V	

**DC CHARACTERISTICS**

(0°C to 70°C)

PARAMETER	SYMBOL	MIN	TYP	MAX	UNITS	NOTES
TERMPWR Current	$I_{TP}$			250	mA	1, 3
	$I_{TP}$		5	8	mA	1, 4
Power Down Current	$I_{PD}$		500		$\mu$ A	1, 2, 5
Termination Resistance	$R_{TERM}$	110		118	ohm	1, 2
Die Thermal Shutdown	$T_{SD}$		150		°C	1
Power Down Termination Capacitance	$C_{PD}$		3.0	5.0	pF	1, 2, 5, 6
Input Leakage High	$I_{IH}$	-1.0			$\mu$ A	1, 8
Input Leakage Low	$I_{IL}$			1.0	$\mu$ A	1, 7

**REGULATOR CHARACTERISTICS**

(0°C to 70°C)

PARAMETER	SYMBOL	MIN	TYP	MAX	UNITS	NOTES
Output Voltage	$V_{REF}$	2.7	2.85	3.0	V	1, 2
Drop Out Voltage	$V_{DROP}$		0.75	1.0	V	3, 6
Output Current	$I_{OUT}$			24.0	mA	9
Line Regulation	$L_{REG}$		1.0	2.0	%	1, 4
Load Regulation	$L_{OREG}$		1.3	3.0	%	1, 2
Current Limit	$I_{LIM}$		350		mA	1
Sink Current	$I_{SINK}$	200			mA	1

**NOTES:**

1. 4.00V < TERMPWR < 5.25V.
2. 0.0V < signal lines < 3.0V.
3. All signal lines = 0.0V.
4. All signal lines open.
5.  $\overline{PD}$  = 0.0V.

6. Guaranteed by design; not production tested.
7.  $R_1$  through  $R_9$  only.
8.  $R_1$  through  $R_9$  and  $\overline{PD}$ .
9.  $V_{\text{SIGNAL}}=0.2\text{V}$ .

### DS2105Z SCSI TERMINATOR 16-PIN SOIC (150 MIL)

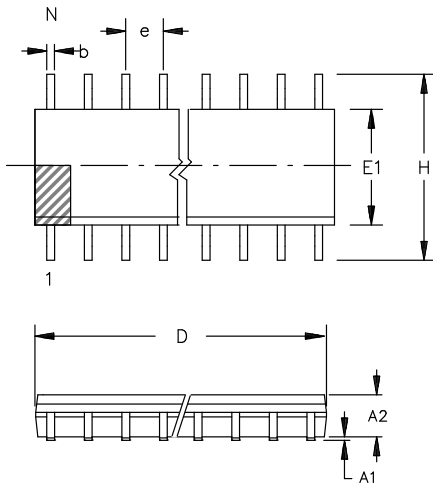

PKG	16-PIN	
DIM	MIN	MAX
A IN. MM	0.053 1.35	0.069 1.75
A1 IN. MM	0.004 0.10	0.010 0.25
A2 IN. MM	0.048 1.24	0.062 1.57
b IN. MM	0.012 0.30	0.020 0.50
C IN MM	0.007 0.17	0.011 0.28
D IN. MM	0.386 9.80	0.393 9.98
e IN. MM	0.050 BSC 1.27 BSC	
E1 IN. MM	0.150 3.81	0.158 4.01
H IN. MM	0.230 5.84	0.244 6.20
L IN. MM	0.016 0.40	0.050 0.89
$\theta$	0°	8°

## DS2105S SCSI TERMINATOR 16-PIN SOIC (300 MIL)

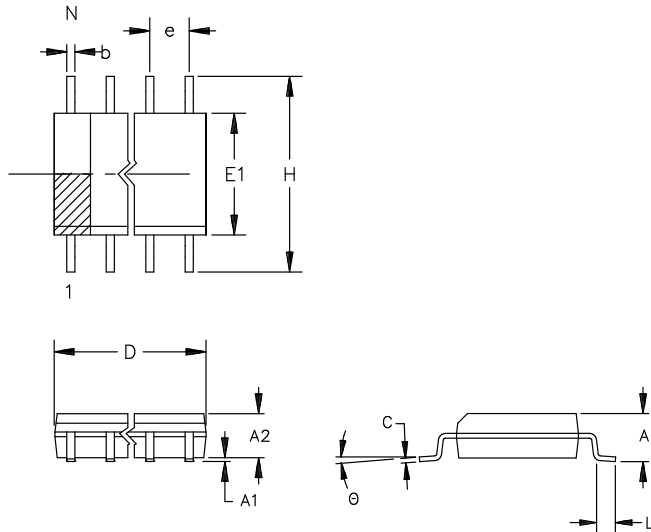

The chamfer on the body is optional. If it is not present, a terminal 1 identifier must be positioned so that 1/2 or more of its area is contained in the hatched zone.

PKG	16-PIN	
DIM	MIN	MAX
A IN. MM	0.094 2.38	0.105 2.68
A1 IN. MM	0.004 0.102	0.012 0.30
A2 IN. MM	0.089 2.26	0.095 2.41
b IN. MM	0.013 0.33	0.020 0.51
C IN MM	0.009 0.229	0.013 0.33
D IN. MM	0.398 10.11	0.412 10.46
e IN. MM	0.050 BSC 1.27 BSC	
E1 IN. MM	0.290 7.37	0.300 7.62
H IN MM	0.398 10.11	0.416 10.57
L IN MM	0.016 0.40	0.040 1.02
$\theta$	0°	8°