



Chipsmall Limited consists of a professional team with an average of over 10 year of expertise in the distribution of electronic components. Based in Hongkong, we have already established firm and mutual-benefit business relationships with customers from,Europe,America and south Asia,supplying obsolete and hard-to-find components to meet their specific needs.

With the principle of “Quality Parts,Customers Priority,Honest Operation,and Considerate Service”,our business mainly focus on the distribution of electronic components. Line cards we deal with include Microchip,ALPS,ROHM,Xilinx,Pulse,ON,Everlight and Freescale. Main products comprise IC,Modules,Potentiometer,IC Socket,Relay,Connector.Our parts cover such applications as commercial,industrial, and automotives areas.

We are looking forward to setting up business relationship with you and hope to provide you with the best service and solution. Let us make a better world for our industry!



Contact us

Tel: +86-755-8981 8866 Fax: +86-755-8427 6832

Email & Skype: info@chipsmall.com Web: www.chipsmall.com

Address: A1208, Overseas Decoration Building, #122 Zhenhua RD., Futian, Shenzhen, China



DALLAS
SEMICONDUCTOR

DS2114
SCSI Terminator

FEATURES

- Fully compliant with SCSI, SCSI-2 and SCSI-3 standards
- Provides active termination for nine signal lines
- Laser-trimmed 110 ohms termination resistors have 2% tolerance
- Low dropout voltage regulator
- Fully supports actively negated SCSI signals
- Onboard thermal shutdown circuitry
- Narrow 16-pin plastic SOIC (DS2114Z)

PIN ASSIGNMENT

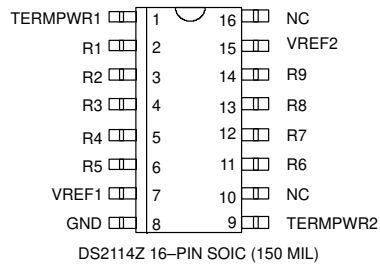

DESCRIPTION

The SCSI-2 and SCSI-3 standards recommend the use of active terminations at both ends of every cable segment in a SCSI system with single-ended drivers and receivers. The DS2114 SCSI Terminator, which is fully compliant with these standards, enables the designer to gain the benefits of active termination: greater immunity to voltage drops on the TERMPWR (Termination PoWeR) line, enhanced high-level noise im-

munity, intrinsic TERMPWR decoupling, and very low quiescent current consumption. The DS2114 integrates a regulator and nine precise 110 ohms termination resistors into a monolithic IC. The DS2114 is intended for cable end terminator assemblies and devices where the terminators do not need to be isolated from the SCSI bus.

FUNCTIONAL DESCRIPTION

The DS2114 consists of a bandgap reference, buffer amplifier, and nine termination resistors (Figure 1). The bandgap reference circuit produces a precise 2.55 volts level which is fed to a buffer amplifier. The buffer produces a 2.85 volts level and is capable of sourcing at least 24 mA into each of the termination resistors when the signal line is low (active). When the driver for a given signal line turns off, the terminator will pull the signal line to 2.85 volts (quiescent state). To handle actively negated SCSI signals, the buffer can sink at least 200 mA and V_{ref} will move less than 60 mV. When all lines settle in the quiescent state, the regulator will consume about 2.5 mA.

To ensure proper operation, both the TERMPWR1 and TERMPWR2 pins must be connected to the SCSI bus TERMPWR line and both the VREF1 and VREF2 pins must be tied together externally. Each DS2114 requires a 4.7 μ F capacitor connected between the VREF pins and ground. Figure 2 details a typical SCSI bus configuration. In an 8-bit wide SCSI bus arrangement ("A" Cable), two DS2114's would be needed at each end of the SCSI cable in order to terminate the 18 active signal lines. In a 16-bit wide SCSI bus arrangement ("P" Cable), three DS2114's would be needed at each end of the SCSI cable in order to terminate the 27 active signal lines.

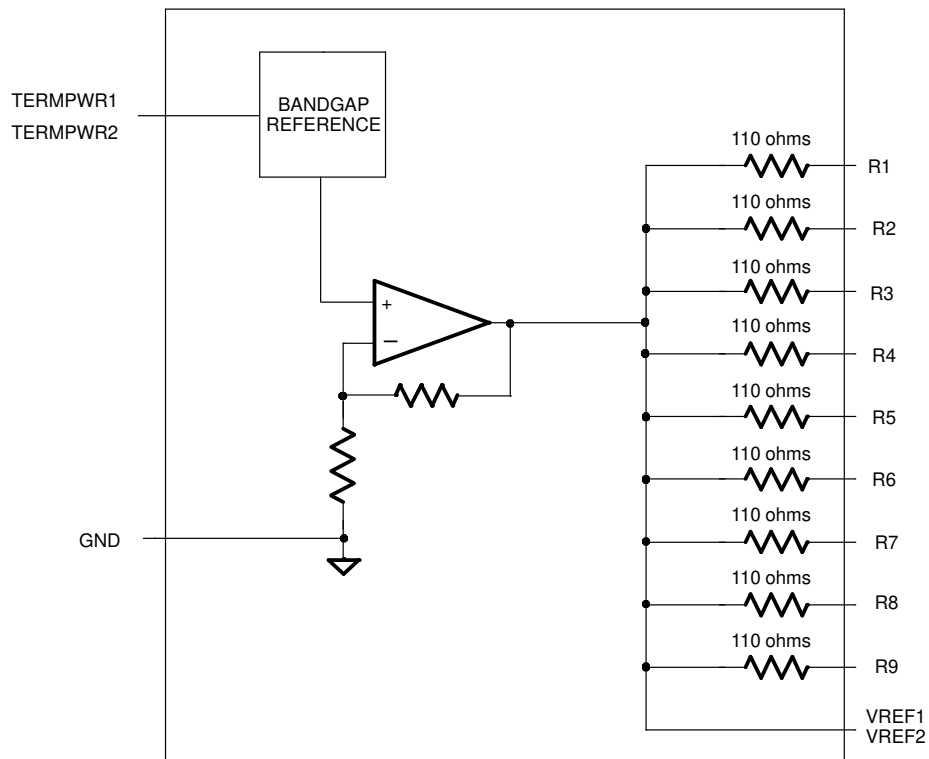
DS2114 BLOCK DIAGRAM Figure 1

TYPICAL SCSI BUS CONFIGURATION Figure 2

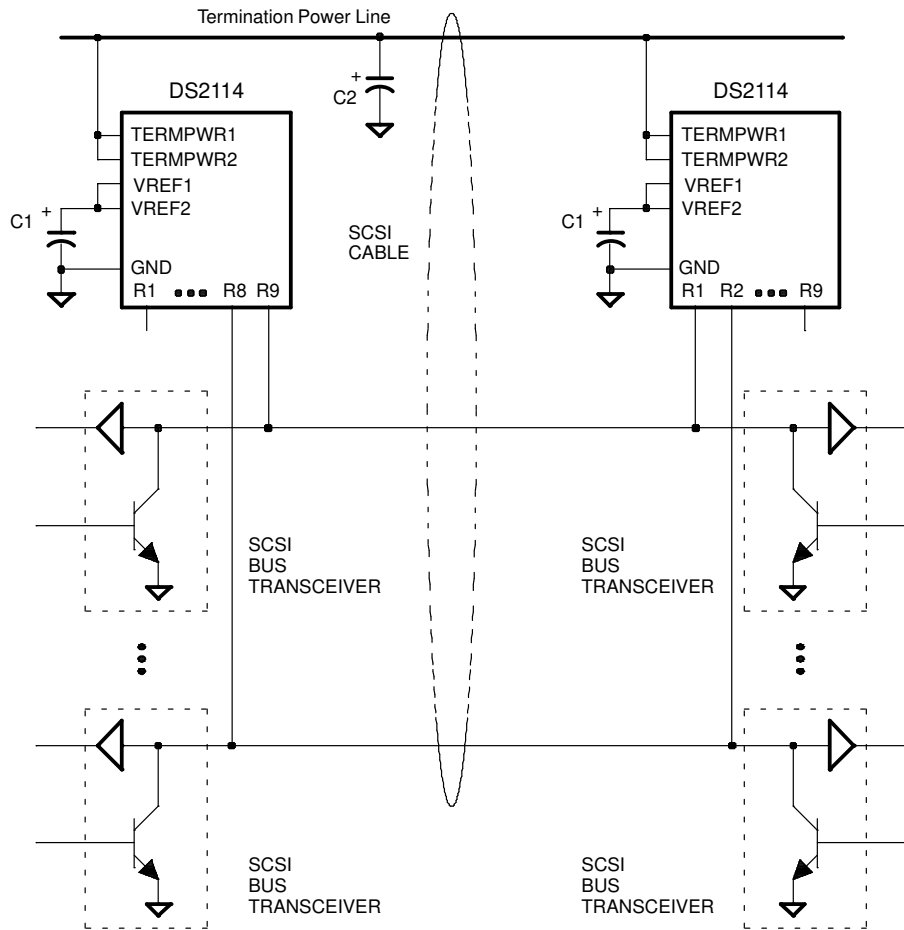
**NOTES:**

1. C1 = 4.7 μ F tantalum
C2 = 2.2 μ F tantalum or 4.7 μ F aluminum
2. If the DS2114 is to be embedded into a peripheral that will act as a target on a SCSI bus, it is recommended that TERMPWR be derived from the SCSI cable, not generated locally. In this configuration, if a power failure occurs in the peripheral, it will not affect the bus.
3. A high frequency bypass capacitor (0.1 μ F recommended) can be added in parallel to C1 for applications using fast rise/fall time drivers.

PIN DESCRIPTION Table 1

DS2114Z PIN	SYMBOL	DESCRIPTION
1	TERMPWR1	Termination Power 1. Should be connected to the SCSI TERMPWR line. Must be decoupled with either a 2.2 μ F or 4.7 μ F. See Figure 2.
2	R1	Signal Termination 1. 110 ohms termination.
3	R2	Signal Termination 2. 110 ohms termination.
4	R3	Signal Termination 3. 110 ohms termination.
5	R4	Signal Termination 4. 110 ohms termination.
6	R5	Signal Termination 5. 110 ohms termination.
7	VREF1	Reference Voltage 1. Must be externally connected directly to the VREF2 pin. Must be decoupled with a 4.7 μ F capacitor as shown in Figure 2.
8	GND	Ground. Signal ground; 0.0 volts.
9	TERMPWR2	Termination Power 2. Should be connected to the SCSI TERMPWR line. Must be decoupled with either a 2.2 μ F or 4.7 μ F. See Figure 2.
11	R6	Signal Termination 6. 110 ohms termination.
12	R7	Signal Termination 7. 110 ohms termination.
13	R8	Signal Termination 8. 110 ohms termination.
14	R9	Signal Termination 9. 110 ohms termination.
10, 16	NC	No Connect. Do not connect any signal to these pins.
15	VREF2	Reference Voltage 2. Must be externally connected directly to the VREF1 pin. Must be decoupled with a 4.7 μ F capacitor as shown in Figure 2.

ABSOLUTE MAXIMUM RATINGS*

Voltage on Any Pin Relative to Ground	-1.0V to +7.0V
Operating Temperature	0°C to 70°C
Storage Temperature	-55°C to +125°C
Soldering Temperature	260°C for 10 seconds

* This is a stress rating only and functional operation of the device at these or any other conditions above those indicated in the operation sections of this specification is not implied. Exposure to absolute maximum rating conditions for extended periods of time may affect reliability.

The Dallas Semiconductor DS2114 is built to the highest quality standards and manufactured for long term reliability. All Dallas Semiconductor devices are made using the same quality materials and manufacturing methods. However, the DS2114 is not exposed to environmental stresses, such as burn-in, that some industrial applications require. For specific reliability information on this product, please contact the factory in Dallas at (972) 371-4448.

RECOMMENDED OPERATING CONDITIONS

(0°C to 70°C)

PARAMETER	SYMBOL	MIN	TYP	MAX	UNITS	NOTES
TERMPWR Voltage	V_{TP}	4.00		5.50	V	

DC CHARACTERISTICS

(0°C to 70°C)

PARAMETER	SYMBOL	MIN	TYP	MAX	UNITS	NOTES
TERMPWR Current	I_{TP}			250	mA	1, 3
	I_{TP}		5	8	mA	1, 4
Termination Resistance	R_{TERM}	110		116	ohms	1, 2
Die Thermal Shutdown	T_{SD}	150			°C	1, 5
Termination Capacitance	C_T		5.0		pF	1, 2, 5

REGULATOR CHARACTERISTICS

(0°C to 70°C)

PARAMETER	SYMBOL	MIN	TYP	MAX	UNITS	NOTES
Output Voltage	V_{REF}	2.7	2.85	3.0	V	1, 2
Drop Out Voltage	V_{DROP}		0.75	1.0	V	3, 5
Line Regulation	L_{REG}		1.0	2.0	%	1, 4
Output Current	I_{OUT}			24.0	mA	6
Load Regulation	L_{OREG}		1.3	3.0	%	1, 3
Current Limit	I_{LIM}	280		500	mA	1
Sink Current	I_{SINK}	200			mA	1

NOTES:

- 4.00 volts < TERMPWR < 5.50 volts.
- 0.0 volts < signal lines < TERMPWR.
- All signal lines = 0.0 volts.
- All signal lines open.
- Guaranteed by design; not production tested.
- $V_{SIGNAL} = 0.2V$.

DS2114Z SCSI TERMINATOR 16-PIN SOIC (150 MIL)

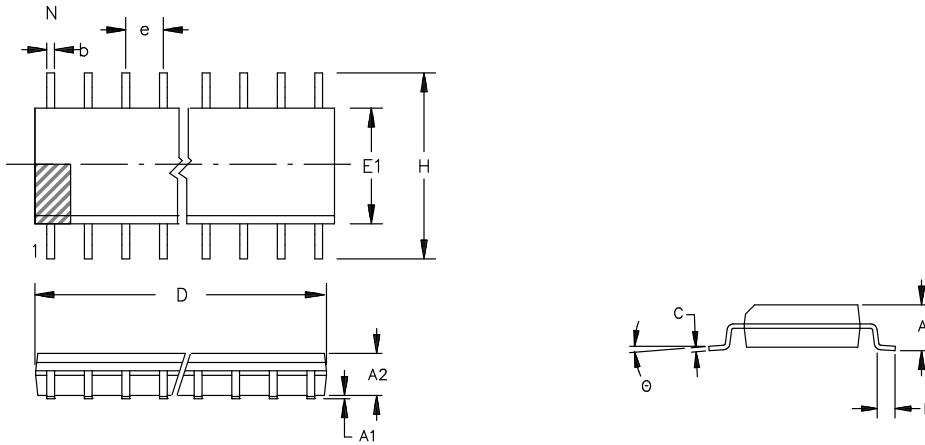

PKG	16-PIN	
DIM	MIN	MAX
A IN. MM	0.053 1.35	0.069 1.75
A1 IN. MM	0.004 0.10	0.010 0.25
A2 IN. MM	0.048 1.24	0.062 1.57
b IN. MM	0.012 0.30	0.020 0.50
C IN MM	0.007 0.17	0.011 0.28
D IN. MM	0.386 9.80	0.393 9.98
e IN. MM	0.050 BSC 1.27 BSC	
E1 IN. MM	0.150 3.81	0.158 4.01
H IN. MM	0.230 5.84	0.244 6.20
L IN. MM	0.016 0.40	0.050 0.89
θ	0°	8°