



Chipsmall Limited consists of a professional team with an average of over 10 year of expertise in the distribution of electronic components. Based in Hongkong, we have already established firm and mutual-benefit business relationships with customers from,Europe,America and south Asia,supplying obsolete and hard-to-find components to meet their specific needs.

With the principle of “Quality Parts,Customers Priority,Honest Operation,and Considerate Service”,our business mainly focus on the distribution of electronic components. Line cards we deal with include Microchip,ALPS,ROHM,Xilinx,Pulse,ON,Everlight and Freescale. Main products comprise IC,Modules,Potentiometer,IC Socket,Relay,Connector.Our parts cover such applications as commercial,industrial, and automotives areas.

We are looking forward to setting up business relationship with you and hope to provide you with the best service and solution. Let us make a better world for our industry!



Contact us

Tel: +86-755-8981 8866 Fax: +86-755-8427 6832

Email & Skype: info@chipsmall.com Web: www.chipsmall.com

Address: A1208, Overseas Decoration Building, #122 Zhenhua RD., Futian, Shenzhen, China



PIN DESCRIPTION Table 1

PIN	SYMBOL	TYPE	DESCRIPTION
3,4,12,14,21,22	GND	-	Ground. Tie to system ground.
6,7,8,9,10,11,28	VCC	-	Positive Supply. Tie to system +5 volt supply.
1	$\overline{\text{PD}}$	O	Power-Down Active Low. Will toggle low during Power-Down mode.
5	PD	O	Power-Down Active High. Will toggle high during Power-Down mode.
15	NC	-	No Connect. Do not connect any signal to this pin.
2	$\overline{\text{RST}}$	I	Reset. When this pin is low, the internal DSP algorithm is in a reset state. On power-up, this pin should be held low for at least 100 ms after MCLK is stable.
13	MCLK	I	Master Processing Clock. The clock used for the internal DSP engine. Should be in the range of 12 to 16 MHz. MCLK can be asynchronous to any other clock signal on the DS2132A. The duty cycle should be 50% ($\pm 5\%$).
16	CDIN	I	Compressed Data Port Input. Serial input for compressed audio data or DS2132A commands. Samples on the falling edges of CLK. The compressed data is expanded to 8-bit PCM which is output on PCMOUT.
17,26	CLK	I	Clock. This clock is used to sample data at CDIN and PCMIN and output data at CDOUT and PCMOUT. CLK must be synchronous with FS. See Figure 3.
18,25	FS	I	Frame Sync. This input must be an 8 KHz clock with a pulse width high time of one to nine CLK cycles for proper operation. See Figure 3.
19	TRI_OUT	O	CDOUT Tri-state Control Out. This output should be tied to the TRI_IN pin (pin 23) for proper operation; will be low when CDOUT is active.
20	CDOUT	O	Compressed Data Port Output. Serial output for compressed audio data or status information, updated on the rising edge of CLK.
23	TRI_IN	I	CDOUT Tri-state Control In. This input should be tied to the TRI_OUT pin (pin 19) for proper operation. If this pin is forced high, CDOUT will not go active.
24	PCMOUT	O	PCM Port Output. Output for expanded data which is in the standard 8-bit μ -law format. Data is updated on the rising edges of CLK.
27	PCMIN	I	PCM Port Input. Input for the 8-bit serial μ -law PCM data which would normally be supplied by a codec/filter device. Data is sampled on the falling edges of CLK.

FUNCTIONAL DESCRIPTION

A typical digital answering machine using the DS2132A is shown in Figure 1. The system consists of a standard telephone CODEC (CODer-DECoder) device, the DS2132A, a microcontroller, and a bank of DRAM. The implementation shown is with a Hitachi CODEC and a 8051-type microcontroller but a wide variety of

CODECs and microcontrollers can be used with the DS2132A. It is only important that the CODEC have serial digital I/O and have μ -law ("Mu" law) companding. Table 2 lists some CODECs that will work with the DS2132A. There is a separate Application Note that explains how to connect these CODECs to the DS2132A.

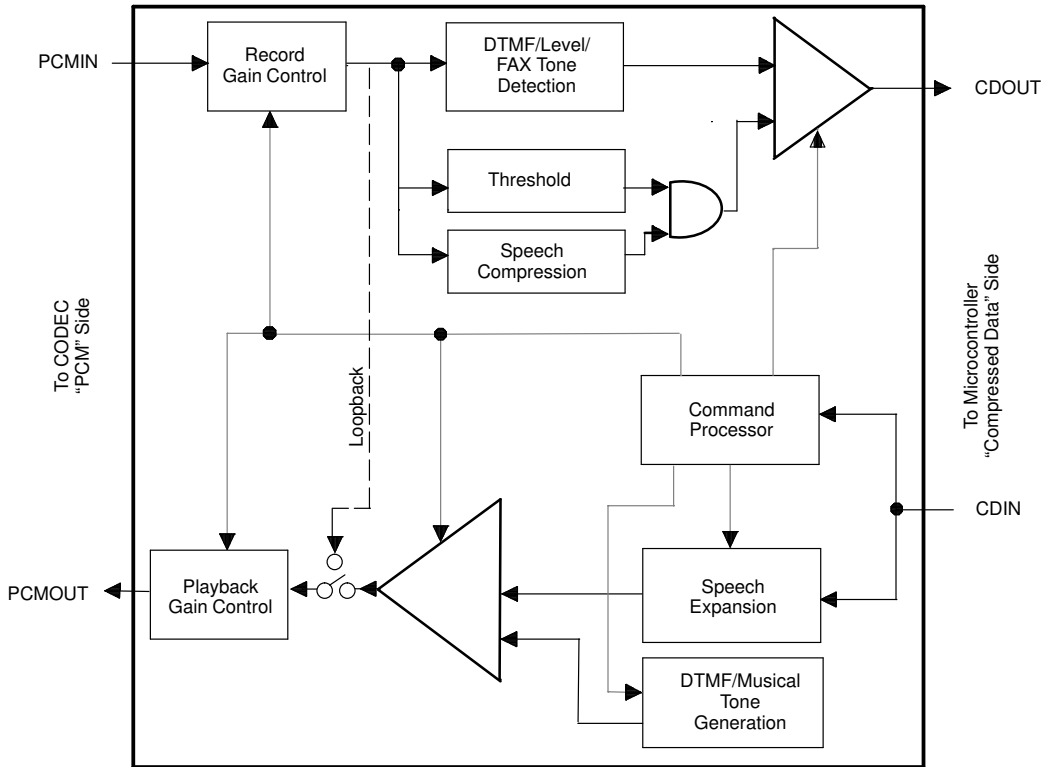
DS2132A BLOCK DIAGRAM Figure 2

OPERATION OF THE CD AND PCM PORTS

As mentioned earlier, the DS2132A essentially contains two separate serial ports, one for the DS2132A to microcontroller interface (the CD Port) and one for the CODEC to DS2132A interface (the PCM Port). The Compressed Data (CD) Port is used to send compressed speech information from the DS2132A to the microcontroller and vice versa. The CD Port is also used to monitor the current status of the DS2132A and it is used to issue instructions to the DS2132A. The CD Port consists of the CDIN, CDOUT, CLK, and FS pins (the CLK

and FS pins are shared with the CODEC). The PCM Port is used to transfer uncompressed speech data between the DS2132A and the CODEC. It consists of the PCMIN, PCMOUT, CLK, and FS pins. Figure 3 details the DS2132A CD and PCM port signals. All communication begins with the frame sync (FS) signal. It indicates to the DS2132A and the CODEC that a byte of information will follow. Note that the PCM Port operates on a MSB first basis and the CD Port operates on a LSB first basis.

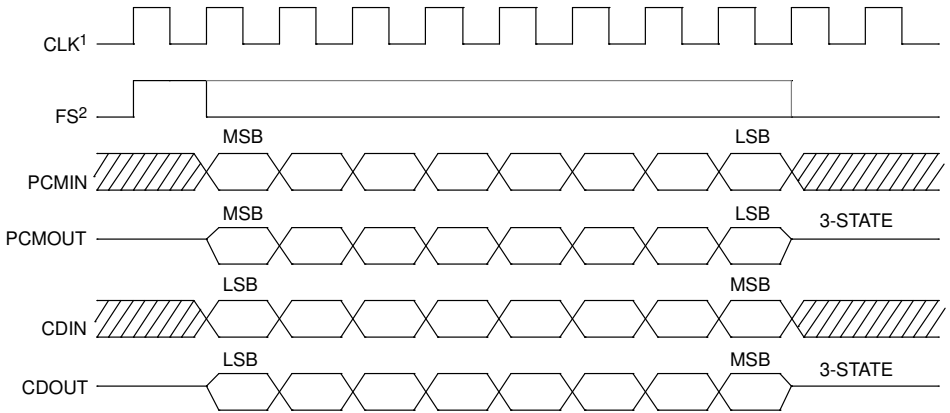
CD & PCM PORT I/O DIAGRAM Figure 3**NOTES:**

1. The CLK period must be between 128 KHz and 4.096 MHz
2. The FS pulse must be between 1 and 9 (inclusive) CLK periods long

On the PCM Port, data will be transferred from the CODEC to the DS2132A via one path and transferred from the DS2132A to the CODEC via another path. These transfers take place every 125 μ s (as determined by the FS signal). Although the CD Port also transfers data every 125 μ s, it operates much differently than does the PCM Port. The CD Port constantly toggles back and forth in its data transfer direction. During one frame

sync, the microcontroller will transfer either compressed speech data or command information to the DS2132A and during the next frame sync, the transfer direction will switch and the DS2132A will send either compressed speech data or status information to the microcontroller. Hence, the CD Port is truly bidirectional. See Figure 4.

CD PORT FLOW STRUCTURE Figure 4

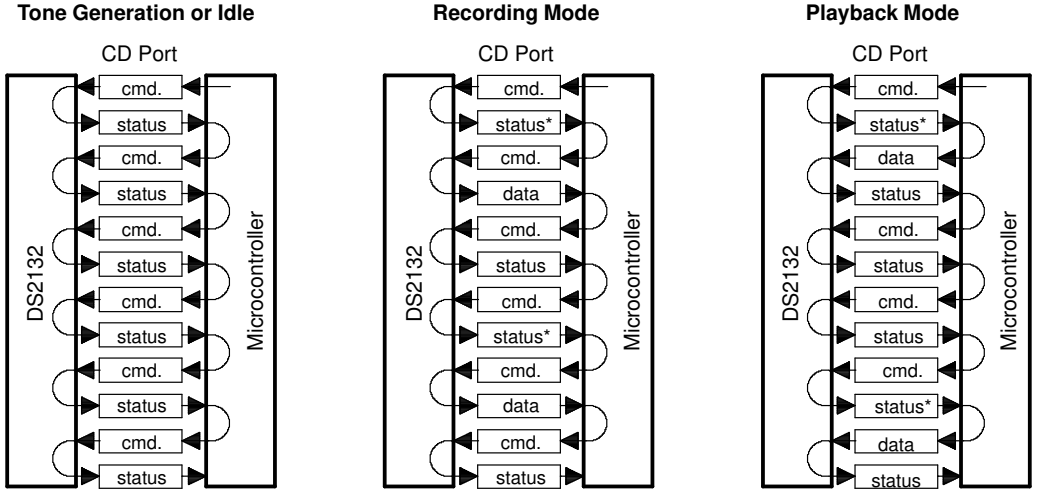

NOTE: Status Bytes marked with an asterisk (*) indicate bytes with the MSB set to 1.

CD PORT I/O STRUCTURE Figure 5

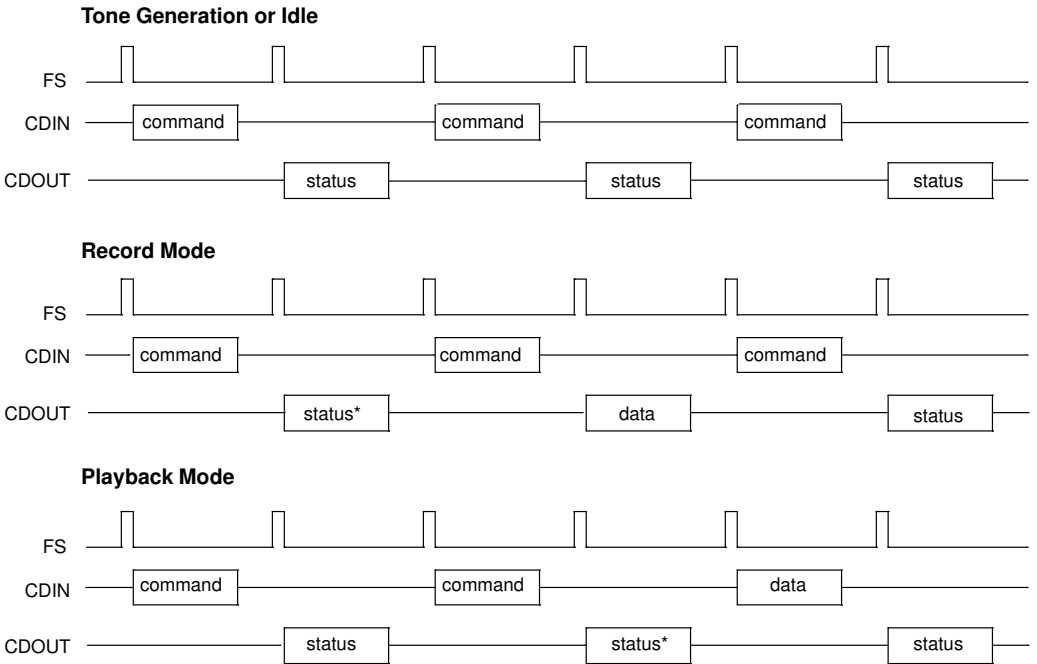

There are three types of bytes that can be transferred on the CD Port; Command Bytes, Status Bytes, and Compressed Speech Data Bytes (or simply Data Bytes). The Command Bytes are always transferred from the microcontroller to the DS2132A to instruct the processor to perform a particular task like transmit a tone. All of the possible commands that can be sent to the DS2132A are listed in Table 3. Status Bytes are always transferred from the DS2132A to the microcontroller. They inform the microcontroller if a DTMF digit is being

received, or what the current energy level is. See Figure 6. Finally, there are Data Bytes which are transferred from the DS2132A to the microcontroller during a “recording” and from the microcontroller to the DS2132A during a “playback”. See Figure 5. When recording, the microcontroller must read the MSB of the Status Byte to discriminate between Data Bytes and Status Bytes. When playing back, the microcontroller must read the MSB of the Status Byte to know when to send a Command Byte and when to send a Data Byte.

STATUS BYTE FORMAT Figure 6

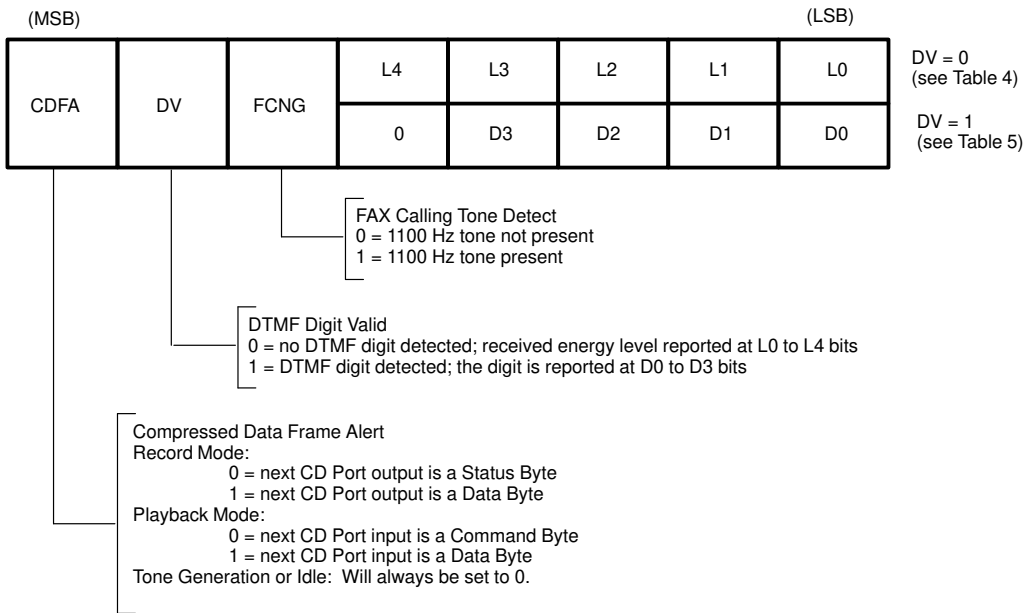

SYNCHRONIZING THE CD PORT

On power-up, the first task of the microcontroller is to “synchronize” the CD Port. It can accomplish this by listening to what the DS2132A is sending it. On power-up (after the \overline{RST} pin is returned high), the DS2132A will be in the Idle mode awaiting a command from the microcontroller. Hence it will be alternately sending a Status Byte to the microcontroller and taking in a Command Byte. In Figure 1, there is a pull-up resistor on the CD Port to insure that on power-up, the microcontroller will send the “no update” command to the DS2132A, which is [FF]. When the microcontroller reads a value other than [FF], then it knows that the byte it just read is a Status Byte and hence it will then know that the next byte will be a Command Byte and it will be synchronized.

RECORD & PLAYBACK MODES

Figure 7 shows two brief flowcharts on what actions the microcontroller would follow to instruct the DS2132A to compress (Record Mode) or expand speech (Playback Mode) data. Before a recording or a playback is to begin, it is recommended that the microcontroller first set the gain to a nominal position. Then, if needed, the gain can be adjusted as the recording or playback is occurring. For example, as the recording process begins, the microcontroller can monitor the incoming speech energy levels via the Status Byte. If the incoming speech level is too low or too high, the gain can be adjusted accordingly. The microcontroller can exit the Recording or Playback Modes by sending the Idle command.

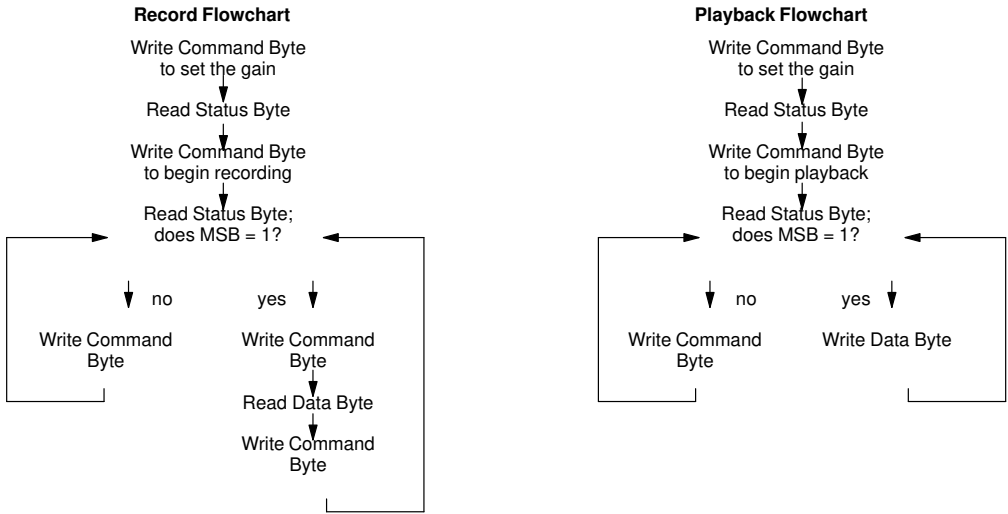
RECORD & PLAYBACK FLOWCHARTS Figure 7**LOOPBACK MODE**

The DS2132A contains a Loopback Mode that is useful in debugging the CODEC to DS2132A interface and in adjusting the analog circuits to the proper gain/attenuation levels. In the Loopback Mode, the DS2132A routes the incoming digitized audio signal received at the PCMIN pin, back to the PCMOUT pin after making gain adjustments. See Figure 2. Notice that the route includes the record and playback gain circuits. The Loopback mode can be enabled at any time. When the Loopback is enabled, the generated tones or expanded speech are ignored. See Figure 2. The DS2132A will enter the Loopback mode if a Command Byte of [08] is sent to it by the microcontroller. The Loopback mode will be exited upon receiving the Exit Loopback Mode command.

FAX CALLING TONE DETECT

According to CCITT Recommendation T.30, originating automatic FAX machines should transmit an 1100 Hz tone for 0.5 seconds every 3.5 seconds (on for 0.5's; off for 3.0's). This tone is meant as an indication to the called station that a non-voice instrument is making the call. The Status Byte in the DS2132A reports if a 1100 Hz tone is being received. This detection can be used to determine if a FAX machine has called the answering machine. The answering machine will then know not to record the incoming call and to route the call to a FAX machine.

COMMAND BYTE OPTIONS Table 3

[FF]	No update	[B8]	Generate musical note "E" (659 Hz)
[00]	No update	[B9]	Generate musical note "F" (698 Hz)
[BE]	Idle	[BA]	Generate musical note "G" (784 Hz)
[08]	Enter Loopback mode	[9B]	Generate bright musical note "A" one octave higher (880+2640 Hz)
[09]	Exit Loopback mode	[9C]	Generate bright musical note "B" one octave higher (988+2974 Hz)
[04]	Enter Power-Down mode	[BB]	Generate musical note "A" one octave higher (880 Hz)
[05]	Exit Power-Down mode	[BC]	Generate musical note "B" one octave higher (988 Hz)
[4A]	Set recording path gain to +30 dB	[25]	Record at Standard rate (9.8Kbps)
[49]	Set recording path gain to +27 dB	[27]	Record at Extended rate (4.9Kbps)
[48]	Set recording path gain to +24 dB	[28]	Playback at Standard rate (9.8Kbps) or Premium Rate (16Kbps) with echo cancellation enabled
[47]	Set recording path gain to +21 dB	[2A]	Playback at Extended rate (4.9Kbps) or Intermediate Rate (8Kbps) with echo cancellation enabled
[46]	Set recording path gain to +18 dB	[23]	Record at Intermediate rate (8Kbps)
[45]	Set recording path gain to +15 dB	[21]	Record at Premium rate (16Kbps)
[44]	Set recording path gain to +12 dB	[20]	Playback at Standard rate (9.8 Kbps) or Premium rate [16Kbps] with echo cancellation disabled
[43]	Set recording path gain to +9 dB	[22]	Playback at Extended rate (4.9Kbps) or Intermediate rate (8Kbps) with echo cancellation disabled
[42]	Set recording path gain to +6 dB	[6A]	Set playback path gain to +30 dB
[41]	Set recording path gain to +3 dB	[69]	Set playback path gain to +27 dB
[40]	Set recording path gain to 0 dB	[68]	Set playback path gain to +24 dB
[5F]	Set recording path gain to -3 dB	[67]	Set playback path gain to +21 dB
[5E]	Set recording path gain to -6 dB	[66]	Set playback path gain to +18 dB
[5D]	Set recording path gain to -9 dB	[65]	Set playback path gain to +15 dB
[5C]	Set recording path gain to -12 dB	[64]	Set playback path gain to +12 dB
[5B]	Set recording path gain to -15 dB	[63]	Set playback path gain to +9 dB
[5A]	Set recording path gain to -18 dB	[62]	Set playback path gain to +6 dB
[59]	Set recording path gain to -21 dB	[61]	Set playback path gain to +3 dB
[58]	Set recording path gain to -24 dB	[60]	Set playback path gain to 0 dB
[57]	Set recording path gain to -27 dB	[7F]	Set playback path gain to -3 dB
[56]	Set recording path gain to -30 dB	[7E]	Set playback path gain to -6 dB
[80]	Generate DTMF "0" (941+1336 Hz)	[7D]	Set playback path gain to -9 dB
[81]	Generate DTMF "1" (697+1209 Hz)	[7C]	Set playback path gain to -12 dB
[82]	Generate DTMF "2" (697+1336 Hz)	[7B]	Set playback path gain to -15 dB
[83]	Generate DTMF "3" (697+1477 Hz)	[7A]	Set playback path gain to -18 dB
[84]	Generate DTMF "4" (770+1209 Hz)	[79]	Set playback path gain to -21 dB
[85]	Generate DTMF "5" (770+1336 Hz)	[78]	Set playback path gain to -24 dB
[86]	Generate DTMF "6" (770+1477 Hz)	[77]	Set playback path gain to -27 dB
[87]	Generate DTMF "7" (852+1209 Hz)	[76]	Set playback path gain to -30 dB
[90]	Generate Dial tone (350+440 Hz)	[88]	Generate DTMF "8" (852+1336 Hz)
[91]	Generate Ringing tone (480+440 Hz)	[89]	Generate DTMF "9" (852+1477 Hz)
[94]	Generate bright musical note "A" (440+1320 Hz)		
[95]	Generate bright musical note "B" (494+1482 Hz)		
[96]	Generate bright musical note "C" (523+1569 Hz)		
[97]	Generate bright musical note "D" (587+1761 Hz)		
[97]	Generate bright musical note "D" (587+1761 Hz)		
[98]	Generate bright musical note "E" (659+1977 Hz)		
[99]	Generate bright musical note "F" (698+2094 Hz)		
[9A]	Generate bright musical note "G" (784+2352 Hz)		
[B4]	Generate musical note "A" (440 Hz)		
[B5]	Generate musical note "B" (494 Hz)		
[B6]	Generate musical note "C" (523 Hz)		
[B7]	Generate musical note "D" (587 Hz)		

[8A]	Generate DTMF "A" (697+1633 Hz)	[13]	Set "off" threshold to -44 dBm
[8B]	Generate DTMF "B" (770+1633 Hz)	[14]	Set "off" threshold to -42 dBm
[8C]	Generate DTMF "C" (852+1633 Hz)	[15]	Set "off" threshold to -40 dBm
[8D]	Generate DTMF "D" (941+1633 Hz)	[16]	Set "off" threshold to -38 dBm
[8E]	Generate DTMF "*" (941+1209 Hz)	[17]	Set "off" threshold to -35 dBm
[8F]	Generate DTMF "#" (941+1477 Hz)	[18]	Set "off" threshold to -32 dBm
[92]	Generate Busy tone (480+620 Hz)	[19]	Set "off" threshold to -29 dBm
[93]	Generate 400 Hz tone	[1A]	Set "off" threshold to -26 dBm
[9E]	Generate 1004 Hz tone	[1B]	Set "off" threshold to -23 dBm
[9D]	Generate 1400 Hz tone	[1C]	Set "off" threshold to -20 dBm
[10]	Set "off" threshold to -50 dBm	[1D]	Set "off" threshold to -17 dBm
[11]	Set "off" threshold to -49 dBm	[1E]	Set "off" threshold to -14 dBm
[12]	Set "off" threshold to -47dBm	[1F]	Set "off" threshold to -11 dBm

NOTES:

1. All tones are generated at 0 dBm0 except for the high tones of DTMF which are at +3 dBm0.
2. The unit dBm0 represents a digital representation of an analog level; throughout this data sheet, the zero reference point of 0 dBm0 was measured with a Hitachi HD44238P CODEC which produces a 1.231Vrms analog signal when sent a "0 dBm0" digital code.
3. All letters and numbers contained in brackets ([]) represent Hexadecimal values.
4. The above hexadecimal code are sent LSB first.

DEFINITION OF THE L0 TO L4 LEVEL BITS

Table 4

L4	L3	L2	L1	L0	ENERGY LEVEL RECEIVED
0	0	0	0	0	<-48dBm0
0	0	0	1	0	-45dBm0
0	0	1	0	0	-42dBm0
0	0	1	0	1	-39dBm0
0	0	1	1	0	-36dBm0
0	0	1	1	1	-33dBm0
0	1	0	0	0	-30dBm0
0	1	0	0	1	-27dBm0
0	1	0	1	0	-24dBm0
0	1	0	1	1	-21dBm0
0	1	1	0	0	-18dBm0
0	1	1	0	1	-15dBm0
0	1	1	1	0	-12dBm0
0	1	1	1	1	-9dBm0
1	0	0	0	0	-6dBm0
1	0	0	0	1	-3dBm0
1	0	0	1	0	0dBm0
1	0	0	1	1	+3dBm0
1	0	1	0	0	+6dBm0
1	0	1	0	1	+9dBm0

DEFINITION OF THE D0 TO D3 DTMF BITS

Table 5

D3	D2	D1	D0	DTMF DIGIT DETECTED
0	0	0	0	DTMF Digit "0"
0	0	0	1	DTMF Digit "1"
0	0	1	0	DTMF Digit "2"
0	0	1	1	DTMF Digit "3"
0	1	0	0	DTMF Digit "4"
0	1	0	1	DTMF Digit "5"
0	1	1	0	DTMF Digit "6"
0	1	1	1	DTMF Digit "7"
1	0	0	0	DTMF Digit "8"
1	0	0	1	DTMF Digit "9"
1	0	1	0	DTMF Digit "A"
1	0	1	1	DTMF Digit "B"
1	1	0	0	DTMF Digit "C"
1	1	0	1	DTMF Digit "D"
1	1	1	0	DTMF Digit "**"
1	1	1	1	DTMF Digit "#"

POWER-DOWN MODE

The DS2132A can be placed into a low-power standby condition by sending the enter power-down command [04] to the DS2132A. The DS2132A will power down within 500 μ s after receiving the power-down command. The MCLK signal should still be applied to the DS2132A in the power-down mode. The CLK and FS signals may be either stopped or continued. In the power-down mode, the DS2132A will consume about 1 mA and the $\overline{\text{PD}}$ pin (Pin 1) will be forced low and the PD pin (Pin 5)

will be forced high. The $\overline{\text{PD}}$ and PD pins can be used to power-down the CODEC. See Figure 2. To exit the power-down mode, the exit power-down command [05] should be sent to the DS2132A. There is no need to issue a hardware reset via the $\overline{\text{RST}}$ pin; the device will reset itself. The DS2132A will power-up in the Idle mode. The microcontroller should wait 1 ms after issuing the exit power-down command before reinitializing the device.

ABSOLUTE MAXIMUM RATINGS*

Voltage on Any Pin Relative to Ground	-1.0V to +7.0V
Operating Temperature	0°C to 70°C
Storage Temperature	-55°C to +125°C
Soldering Temperature	260°C for 10 seconds

* This is a stress rating only and functional operation of the device at these or any other conditions above those indicated in the operation sections of this specification is not implied. Exposure to absolute maximum rating conditions for extended periods of time may affect reliability.

RECOMMENDED DC OPERATING CONDITIONS

(0°C to 70°C)

PARAMETER	SYMBOL	MIN	TYP	MAX	UNITS	NOTES
Logic 0	V_{IL}	-0.3		0.8	V	
Logic 1	V_{IH}	2.0		$V_{CC} + 0.3$	V	
Supply	V_{CC}	4.5		5.5	V	

CAPACITANCE $(t_A = 25^\circ\text{C})$

PARAMETER	SYMBOL	MIN	TYP	MAX	UNITS	NOTES
Input Capacitance	C_{IN}			5	pF	
Output Capacitance	C_{OUT}			10	pF	

DC ELECTRICAL CHARACTERISTICS(0°C to 70°C; $V_{CC} = 5V \pm 10\%$)

PARAMETER	SYMBOL	MIN	TYP	MAX	UNITS	NOTES
Active Supply Current	I_{DDA}		35	40	mA	1,2
Input Leakage	I_{LI}	-1.0		+1.0	μA	
Output Leakage	I_{LO}	-1.0		-1.0	μA	3
Output Current (2.4 V)	I_{OH}	-1.0		-1.0	mA	
Output Current (0.4V)	I_{OL}	+4.0			mA	
Power-Down Current	I_{PD}		1		mA	1,2,4

NOTES:

- $V_{CC} = 5.5V$; CLK=2.048 MHz; MCLK=16 MHz.
- Outputs open; inputs swinging full supply levels.
- PCMOUT and CDOOUT are 3-stated.
- Power-down mode.

DTMF RECEIVER CHARACTERISTICS(0°C to 70°C; $V_{CC} = 5V \pm 10\%$)

PARAMETER	SYMBOL	MIN	TYP	MAX	UNITS	NOTES
Valid Detect Amplitude Range		-40		0	dBm0	1,2
Frequency Deviation Accept		± 1.5			%	3
Frequency Deviation Reject		± 3.5			%	3
Minimum Twist Accept Range		-10		+10	dB	4
Talk Off (Mitel Tape CM7291)			5		Hits	5
Noise Tolerance (Mitel Test Tape CM7291)			-12		dB	6

NOTES:

- 0 dBm0 = 1.231 Vrms when sent through a Hitachi HD44238P CODEC as shown in Figure 1.
- Individual tone level of the DTMF pair with recording path gain set to 0db.
- Percent of nominal frequency for the individual tone; FS = 8 KHz ($\pm 0.1\%$).
- Twist = 20 LOG (High tone/Low tone).
- Talk Off is a measure of the speech immunity of a DTMF receiver; the lower the number of hits, the better the immunity.
- Three KHz bandlimited white noise, referenced to lowest amplitude in the DTMF pair.

DTMF DETECTION TIMING(0°C to 70°C; $V_{CC} = 5V \pm 10\%$)

PARAMETER	SYMBOL	MIN	TYP	MAX	UNITS	NOTES
Tone Duration Accept		40			ms	
Tone Duration Reject				20	ms	
Interdigit Pause Accept		40			ms	
Interdigit Pause Reject				20	ms	

DTMF TONE GENERATOR CHARACTERISTICS(0°C to 70°C; $V_{CC} = 5V \pm 10\%$)

PARAMETER	SYMBOL	MIN	TYP	MAX	UNITS	NOTES
DTMF Frequency Deviation (each tone of the pair)				± 1.0	%	1
Output Distortion (single tone)				-25	dB	2
DTMF Tone Level Twist			± 3		dB	3

NOTES:

- FS = 8.0 KHz $\pm 0.1\%$
- Total harmonic distortion relative to test tone signal.
- Twist = 20 LOG (High tone/Low tone).

DATA INPUT/OUTPUT AC ELECTRICAL CHARACTERISTICS

(0°C to 70°C; $V_{CC} = 5V \pm 10\%$)

PARAMETER	SYMBOL	MIN	TYP	MAX	UNITS	NOTES
CLK Clock Period	t_p	244		7813	ns	1,2
CLK Pulse Width High, Low	t_{WH}, t_{WL}	100			ns	2
CLK Rise, Fall Times	t_R, t_F			20	ns	2
Hold Time from CLK to FS	t_{HOLD}	0			ns	2
Setup Time from FS high CLK low	t_{SF}	50			ns	2
Hold Time from CLK low to FS low	t_{HF}	100			ns	2
Setup Time from PCMIN, CDIN to CLK low	t_{SD}	50			ns	2
Hold Time from PCMIN, CDIN to CLK low	t_{HD}	50			ns	2
Delay Time from CLK to Valid PCMOUT, CDOUT	t_{DO}	10		150	ns	2
Delay Time from CLK to PCMOUT, CDOUT 3-stated	t_{DZ}	20		150	ns	2

NOTES:

- At least nine CLK clocks must be received within first half of the FS period (62.5 μ s).
- See Figure 8.

MASTER CLOCK/RESET AC ELECTRICAL CHARACTERISTICS

(0°C to 70°C; $V_{CC} = 5V \pm 10\%$)

PARAMETER	SYMBOL	MIN	TYP	MAX	UNITS	NOTES
MCLK Period	t_{PM}	62		84	ns	1,2
MCLK Duty Cycle		45		55	%	
MCLK Rise/Fall Times	t_{RM}, t_{FM}			10	ns	2
RST Pulse Width	t_{RST}	100			ms	2

NOTES:

- MCLK = 12 to 16 MHz.
- See Figure 9.

DATA I/O AC TIMING DIAGRAM Figure 8

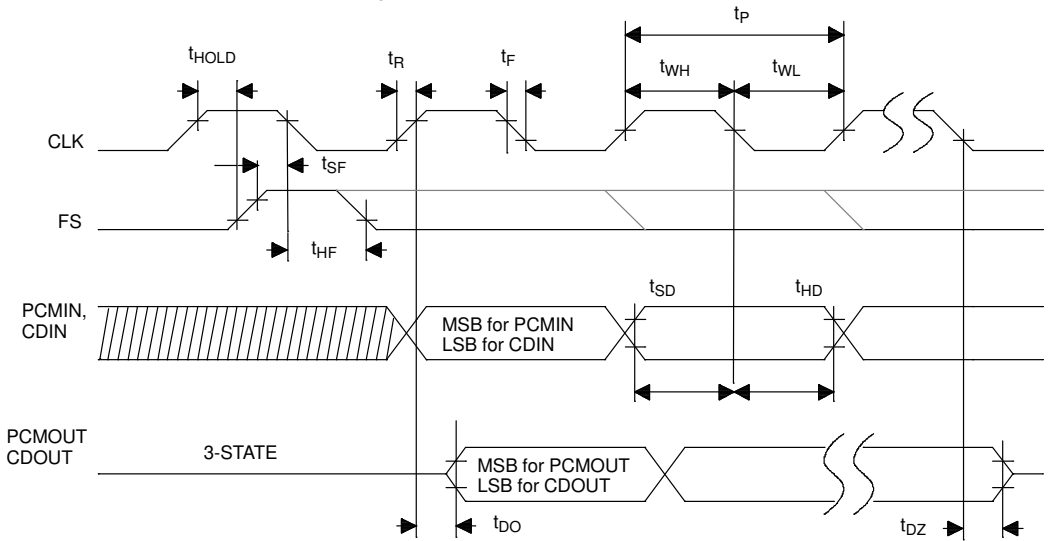

MASTER CLOCK & RESET AC TIMING DIAGRAM Figure 9

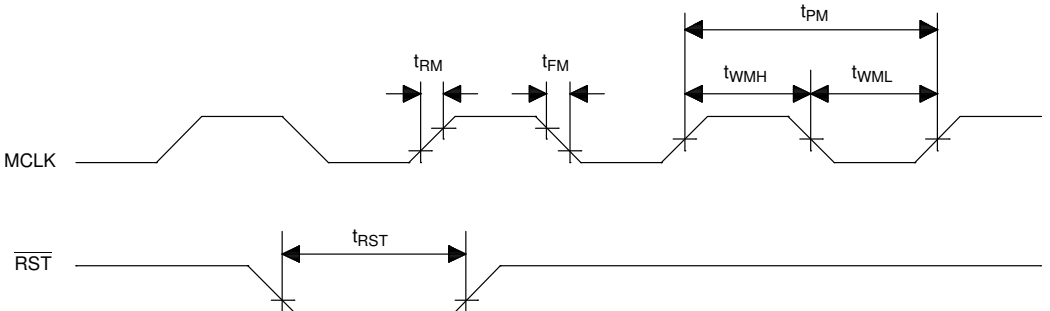

DS2132A DIGITAL ANSWERING MACHINE PROCESSOR

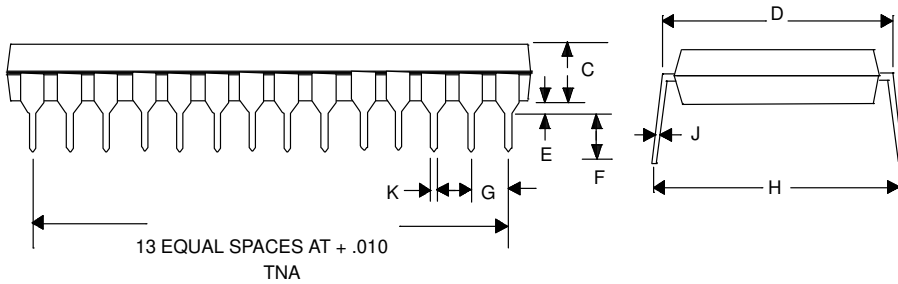
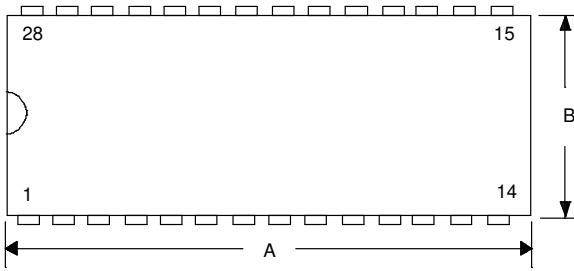

DIM	INCHES	
	MIN	MAX
A	1.445	1.470
B	0.530	0.550
C	0.140	0.160
D	0.600	0.625
E	0.015	0.040
F	0.120	0.145
G	0.090	0.110
H	0.600	0.680
J	0.008	0.012
K	0.015	0.022

DS2132AQ DIGITAL ANSWERING MACHINE PROCESSOR

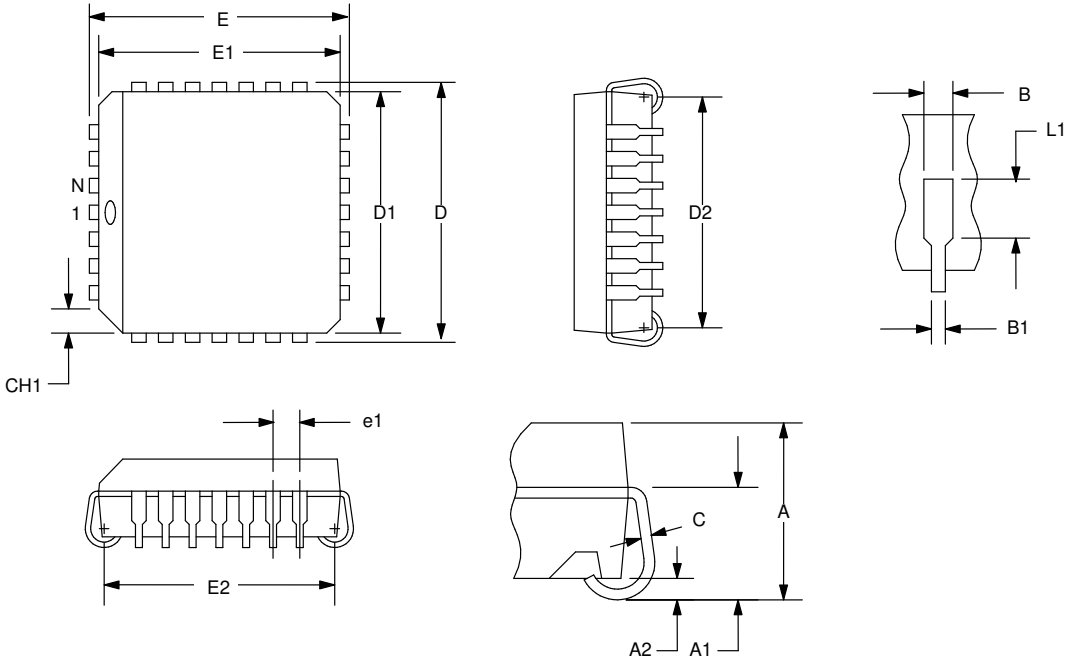

DIM	INCHES	
	MIN	MAX
A	0.165	0.180
A1	0.090	0.120
A2	0.020	—
B	0.026	0.033
B1	0.013	0.021
C	0.009	0.012
D	0.485	0.495
D1	0.450	0.456
D2	0.390	0.430
E	0.485	0.495
E1	0.450	0.456
E2	0.390	0.430
L1	0.060	—
N	28	—
e1	0.050 BSC	
CH1	0.042	0.048