



Chipsmall Limited consists of a professional team with an average of over 10 year of expertise in the distribution of electronic components. Based in Hongkong, we have already established firm and mutual-benefit business relationships with customers from,Europe,America and south Asia,supplying obsolete and hard-to-find components to meet their specific needs.

With the principle of “Quality Parts,Customers Priority,Honest Operation,and Considerate Service”,our business mainly focus on the distribution of electronic components. Line cards we deal with include Microchip,ALPS,ROHM,Xilinx,Pulse,ON,Everlight and Freescale. Main products comprise IC,Modules,Potentiometer,IC Socket,Relay,Connector.Our parts cover such applications as commercial,industrial, and automotives areas.

We are looking forward to setting up business relationship with you and hope to provide you with the best service and solution. Let us make a better world for our industry!



## Contact us

Tel: +86-755-8981 8866 Fax: +86-755-8427 6832

Email & Skype: info@chipsmall.com Web: www.chipsmall.com

Address: A1208, Overseas Decoration Building, #122 Zhenhua RD., Futian, Shenzhen, China



### FEATURES

- Low-power serial transmitter/receiver for battery-backed systems
- Transmitter steals power from receive signal line to save power
- Ultra-low static current, even when connected to RS-232-E port
- Variable transmitter level from +5 to +12 volts
- Compatible with RS-232-E signals
- Available in 8-pin, 150 mil wide SOIC package (DS275S)
- Low-power CMOS

### ORDERING INFORMATION

DS275	8-pin DIP
DS275S	8-pin SOIC
DS275E	14-pin TSSOP

### PIN ASSIGNMENT

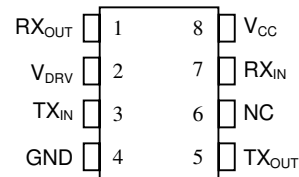

DS275 8-Pin DIP (300-mil)  
 DS275 8-Pin SOIC (150-mil)

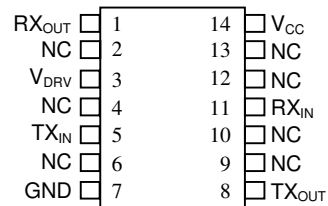

DS275E 14-Pin TSSOP

### PIN DESCRIPTION

RX <sub>OUT</sub>	- RS-232 Receiver Output
V <sub>DRV</sub>	- Transmit driver +V
TX <sub>IN</sub>	- RS-232 Driver Input
GND	- System Ground (0V)
TX <sub>OUT</sub>	- RS-232 Driver Output
NC	- No Connection
RX <sub>IN</sub>	- RS-232 Receive Input
V <sub>CC</sub>	- System Logic Supply (+5V)

### DESCRIPTION

The DS275 Line-Powered RS-232 Transceiver Chip is a CMOS device that provides a low-cost, very low-power interface to RS-232 serial ports. The receiver input translates RS-232 signal levels to common CMOS/TTL levels. The transmitter employs a unique circuit which steals current from the receive RS-232 signal when that signal is in a negative state (marking). Since most serial communication ports remain in a negative state statically, using the receive signal for negative power greatly reduces the DS275's static power consumption. This feature is especially important for battery-powered systems such as laptop computers, remote sensors, and portable medical instruments. During an actual communication session, the DS275's transmitter will use system power (5-12 volts) for positive transitions while still employing the receive signal for negative transitions.

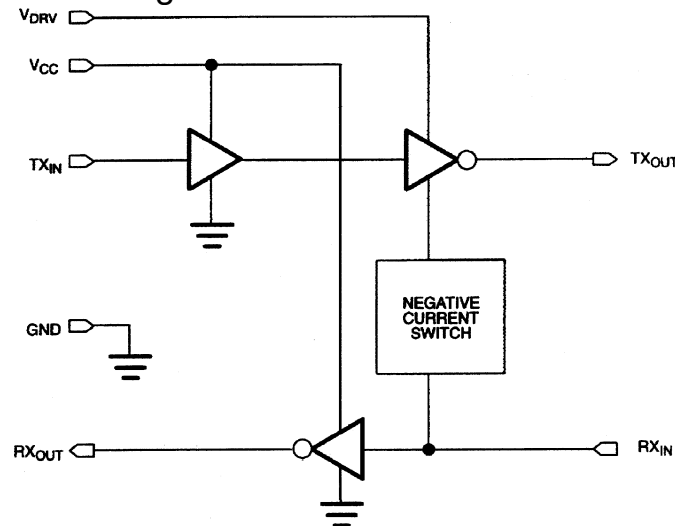
**DS275 BLOCK DIAGRAM Figure 1****OPERATION**

Designed for the unique requirements of battery-backed systems, the DS275 provides a low-power half-duplex interface to an RS-232 serial port. Typically, a designer must use an RS-232 device which uses system power during both negative and positive transitions of the transmit signal to the RS-232 port. If the connector to the RS-232 port is left connected for an appreciable time after the communication session has ended, power will statically flow into that port, draining the battery capacity. The DS275 eliminates this static current drain by stealing current from the receive line (RX<sub>IN</sub>) of the RS-232 port when that line is at a negative level (marking). Since most asynchronous communication over an RS-232 connection typically remains in a marking state when data is not being sent, the DS275 will not consume system power in this condition. System power would only be used when positive-going transitions are needed on the transmit RS-232 output (TX<sub>OUT</sub>) when data is sent. However, since synchronous communication sessions typically exhibit a very low duty-cycle, overall system power consumption remains low.

**RECEIVER SECTION**

The RX<sub>IN</sub> pin is the receive input for an RS-232 signal whose levels can range from  $\pm 3$  to  $\pm 15$  volts. A negative data signal is called a mark while a positive data signal is called a space. These signals are inverted and then level-shifted to normal +5-volt CMOS/TTL logic levels. The logic output associated with RX<sub>IN</sub> is RX<sub>OUT</sub> which swings from +V<sub>CC</sub> to ground. Therefore, a mark on RX<sub>IN</sub> produces a logic 1 at RX<sub>OUT</sub>; a space produces a logic 0.

The input threshold of RX<sub>IN</sub> is typically around 1.8 volts with 500 millivolts of hysteresis to improve noise rejection. Therefore, an input positive-going signal must exceed 1.8 volts to cause RX<sub>OUT</sub> to switch states. A negative-going signal must now be lower than 1.3 volts (typically) to cause RX<sub>OUT</sub> to switch again. An open on RX<sub>IN</sub> is interpreted as a mark, producing a logic 1 at RX<sub>OUT</sub>.

**TRANSMITTER SECTION**

TX<sub>IN</sub> is the CMOS/TTL-compatible input for digital data from the user system. A logic 1 at TX<sub>IN</sub> produces a mark (negative data signal) at TX<sub>OUT</sub> while a logic 0 produces a space (positive data signal). As mentioned earlier, the transmitter section employs a unique driver design that uses the RX<sub>IN</sub> line for swinging to negative levels. The RX<sub>IN</sub> line must be in a marking or idle state to take advantage of this design; if RX<sub>IN</sub> is in a spacing state, TX<sub>OUT</sub> will only swing to ground. When TX<sub>OUT</sub> needs to transition to a positive level, it uses the V<sub>DRV</sub> power pin for this level. V<sub>DRV</sub> can be a voltage supply between 5 to 12

volts, and in many situations it can be tied directly to the +5 volt  $V_{CC}$  supply. *It is important to note that  $V_{DRV}$  must be greater than or equal to  $V_{CC}$  at all times.*

The voltage range on  $V_{DRV}$  permits the use of a 9-volt battery in order to provide a higher voltage level when TXOUT is in a space state. When  $V_{CC}$  is shut off to the DS275 and  $V_{DRV}$  is still powered (as might happen in a battery-backed condition), only a small leakage current (about 50-100 nA) will be drawn. If TXOUT is loaded during such a condition,  $V_{DRV}$  will draw current only if RXIN is not in a negative state. During normal operation ( $V_{CC}=5$  volts),  $V_{DRV}$  will draw less than 2 uA when TXOUT is marking. Of course, when TXOUT is spacing,  $V_{DRV}$  will draw substantially more current—about 3 mA, depending upon its voltage and the impedance that TXOUT sees.

The TXOUT output is slew rate-limited to less than 30 volts/us in accordance with RS-232 specifications. In the event TXOUT should be inadvertently shorted to ground, internal current-limiting circuitry prevents damage, even if continuously shorted.

## RS-232 COMPATIBILITY

The intent of the DS275 is not so much to meet all the requirements of the RS-232 specification as to offer a low-power solution that will work with most RS-232 ports with a connector length of less than 10 feet. As a prime example, the DS275 will not meet the RS-232 requirement that the signal levels be at least  $\pm 5$  volts minimum when terminated by a 3 k $\Omega$  load and  $V_{DRV} = +5$  volts. Typically a voltage of 4 volts will be present at TXOUT when spacing. However, since most RS-232 receivers will correctly interpret any voltage over 2 volts as a space, there will be no problem transmitting data.

## APPLICATIONS INFORMATION

The DS275 is designed as a low-cost, RS-232-E interface expressly tailored for the unique requirements of battery-operated handheld products. As shown in the electrical specifications, the DS275 draws exceptionally low operating and static current. During normal operation when data from the handheld system is sent from the TXOUT output, the DS275 only draws significant  $V_{DRV}$  current when TXOUT transitions positively (spacing). This current flows primarily into the RS-232 receiver's 3-7 k $\Omega$  load at the other end of the attaching cable. When TXOUT is marking (a negative data signal), the  $V_{DRV}$  current falls dramatically since the negative voltage is provided by the transmit signal from the other end of the cable. This represents a large reduction in overall operating current, since typical RS-232 interface chips use charge-pump circuits to establish both positive and negative levels at the transmit driver output.

To obtain the lowest power consumption from the DS275, observe the following guidelines. First, to minimize  $V_{DRV}$  current when connected to an RS-232 port, always maintain TXIN at a logic 1 when data is not being transmitted (idle state). This will force TXOUT into the marking state, minimizing  $V_{DRV}$  current. Second,  $V_{DRV}$  current will drop to less than 100 nA when  $V_{CC}$  is grounded. Therefore, if  $V_{DRV}$  is tied directly to the system battery, the logic +5 volts can be turned off to achieve the lowest possible power state.

## FULL-DUPLEX OPERATION

The DS275 is intended primarily for half-duplex operation; that is, RXIN should remain idle in the marking state when transmitting data out TXOUT and visa versa. However, the part can be operated full-duplex with most RS-232-E serial ports since signals swinging between 0 and +5V will usually be correctly interpreted by an RS-232-E receiver device. The 5-volt swing occurs when TXOUT attempts to swing negative while RXIN is at a positive voltage, which turns on an internal weak pulldown to ground for the TXOUT driver's negative reference. So, transmit mark signals at TXOUT may have voltage jumps from some negative value (corresponding to RXIN marking) to approximately ground. One possible

problem that may occur in this case is if the receiver at the other end requires a negative voltage for recognizing a mark. In this situation, the full-duplex circuit shown in Figure 3 can be used as an alternative. The 22  $\mu\text{F}$  capacitor forms a negative-charge reservoir; consequently, when the TXD line is spacing (positive), TXOUT still has a negative source available for a time period determined by the capacitor and the load resistance at the other end (3-7  $\text{k}\Omega$ ). This circuit was tested from 150-19,200 bps with error-free operation using a SN75154 Quad Line Receiver as the receiver for the TXOUT signal. Note that the SN75154 can have a marking input threshold below ground; hence there is the need for TXOUT to swing both positive and negative in full-duplex operation with this device.

**HANDHELD RS-232-C APPLICATION USING A STEREO MINI-JACK Figure 2**

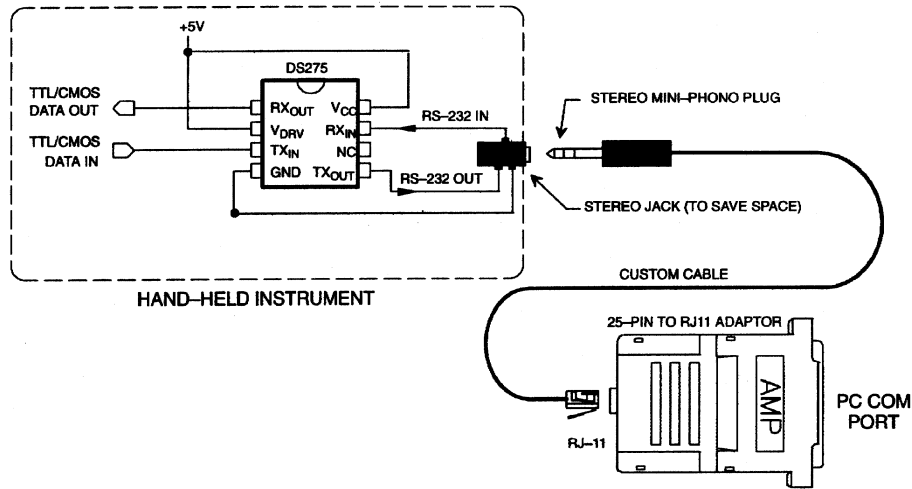

**FULL-DUPLEX CIRCUIT USING NEGATIVE-CHARGE STORAGE Figure 3**

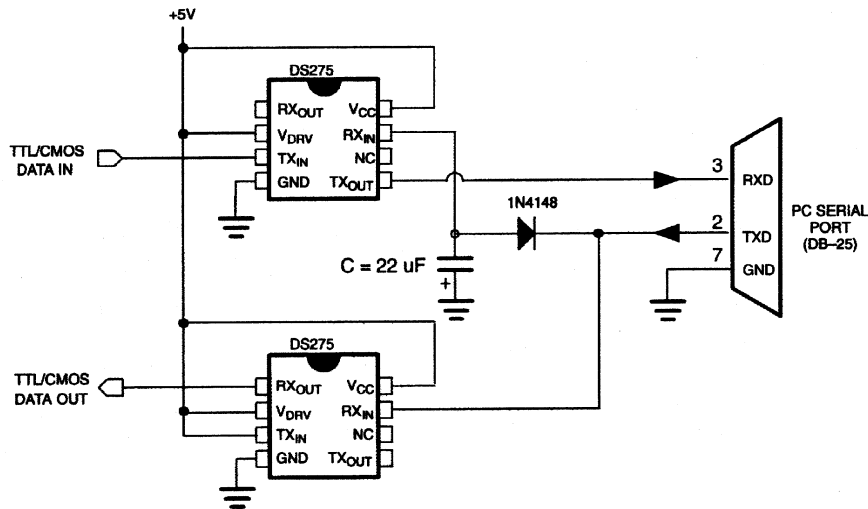

**NOTE:**

The capacitor stores negative charge whenever the TXD signal from the PC serial port is in a marking data state (a negative voltage that is typically -10 volts). The top DS275's TXOUT uses this negative charge reservoir when it is in a marking state. The capacitor will discharge to 0 volts when the TXD line is spacing (and TXOUT is still marking) at a time constant determined by its value and the value of the load resistance reflected back to TXOUT. However, when TXD is marking the capacitor will quickly charge back to -10 volts. Note that TXD remains in a marking state when idle, which improves the performance of this circuit.

**ABSOLUTE MAXIMUM RATINGS\***

V <sub>CC</sub>	-0.3 to +7.0 volts
V <sub>DRV</sub>	-0.3 to +13.0 volts

RX <sub>IN</sub>	±15 volts
TX <sub>IN</sub>	-0.3 to V <sub>CC</sub> + 0.3 volts
TX <sub>OUT</sub>	±15 volts
RX <sub>OUT</sub>	-0.3 to V <sub>CC</sub> + 0.3 volts
Storage Temperature	-55°C to +125°C
Operating Temperature	0°C to 70°C

\* This is a stress rating only and functional operation of the device at these or any other conditions above those indicated in the operation sections of this specification is not implied. Exposure to absolute maximum rating conditions for extended periods of time may affect reliability.

## RECOMMENDED DC OPERATING CONDITIONS

PARAMETER	SYMBOL	MIN	TYP	MAX	UNITS	NOTES
Logic Supply	V <sub>CC</sub>	4.5	5.0	5.5	V	1
Transmit Driver Supply	V <sub>DRV</sub>	4.5	5-12	13.0	V	1
Logic 1 Input	V <sub>IH</sub>	2.0		V <sub>CC</sub> +0.3	V	2
Logic 0 Input	V <sub>IL</sub>	-0.3		+0.8	V	
RS-232 Input Range (RX <sub>IN</sub> )	V <sub>RS</sub>	-15		+15	V	
Dynamic Supply Current TX <sub>IN</sub> = V <sub>CC</sub>	I <sub>DRV1</sub>		400	800	μA	3
	I <sub>CC1</sub>		40	100	μA	
TX <sub>IN</sub> = GND	I <sub>DRV1</sub>		3.8	5.0	μA	
	I <sub>CC1</sub>		40	100	μA	
Static Supply Current TX <sub>IN</sub> = V <sub>CC</sub>	I <sub>DRV2</sub>		1.5	10.0	μA	4
	I <sub>CC2</sub>		10.0	15.0	μA	
TX <sub>IN</sub> = GND	I <sub>DRV2</sub>		3.8	5.0	mA	
	I <sub>CC2</sub>		10.0	20.0	μA	
Driver Leakage Current (V <sub>CC</sub> =0V)	I <sub>DRV3</sub>		0.05	1.0	μA	5

**DC ELECTRICAL CHARACTERISTICS** (0°C to 70°C;  $V_{CC} = V_{DRV} = 5V \pm 10\%$ )

PARAMETER	SYMBOL	MIN	TYP	MAX	UNITS	NOTES
TX <sub>OUT</sub> Level High	V <sub>OTXH</sub>	3.5	4.0	5.0	V	6
TX <sub>OUT</sub> Level Low	V <sub>OTXL</sub>	-8.5	-9.0		V	7
TX <sub>OUT</sub> Short Circuit Current	I <sub>SC</sub>		+60	+85	mA	
TX <sub>OUT</sub> Output Slew Rate	t <sub>SR</sub>			30	V/μs	
Propagation Delay	t <sub>PD</sub>		5		μs	8
RX <sub>IN</sub> Input Threshold Low	V <sub>TL</sub>	0.8	1.2	1.6	V	
RX <sub>IN</sub> Input Threshold High	V <sub>TH</sub>	1.6	2.0	2.4	V	
RX <sub>IN</sub> Threshold Hysteresis	V <sub>HYS</sub>	0.5	0.8		V	9
RX <sub>OUT</sub> Output Current @ 2.4V	I <sub>OH</sub>	-1.0			mA	
RX <sub>OUT</sub> Output Current @ 0.4V	I <sub>OL</sub>			3.2	mA	

**NOTES:**

1. V<sub>DRV</sub> must be greater than or equal to V<sub>CC</sub>.
2. V<sub>CC</sub> = V<sub>DRV</sub> = 5V ± 10%.
3. See test circuit in Figure 4.
4. See test circuit in Figure 5.
5. See test circuit in Figure 6.
6. TX<sub>IN</sub> = V<sub>IL</sub> and TX<sub>OUT</sub> loaded by 3 kΩ to ground.
7. TX<sub>IN</sub> = V<sub>IH</sub>, RX<sub>IN</sub> = -10 volts and TX<sub>OUT</sub> loaded by 3 kΩ to ground.
8. TX<sub>IN</sub> to TX<sub>OUT</sub> - see Figure 7.
9. V<sub>HYS</sub> = V<sub>TH</sub> - V<sub>TL</sub>.

**DYNAMIC OPERATING CURRENT TEST CIRCUIT**  
Figure 4

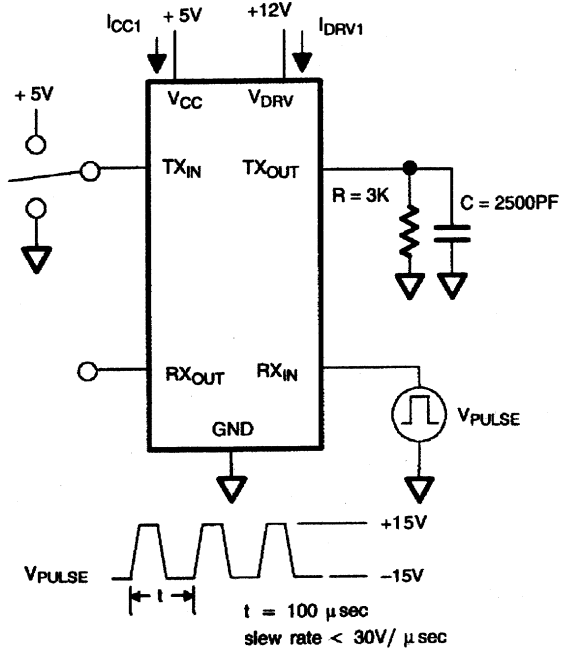

**DRIVER LEAKAGE TEST CIRCUIT**  
Figure 6

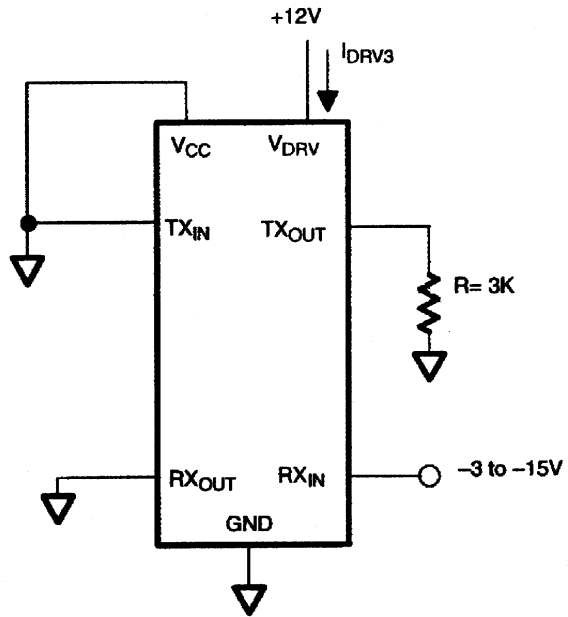

**STATIC OPERATING CURRENT TEST CIRCUIT**  
Figure 5

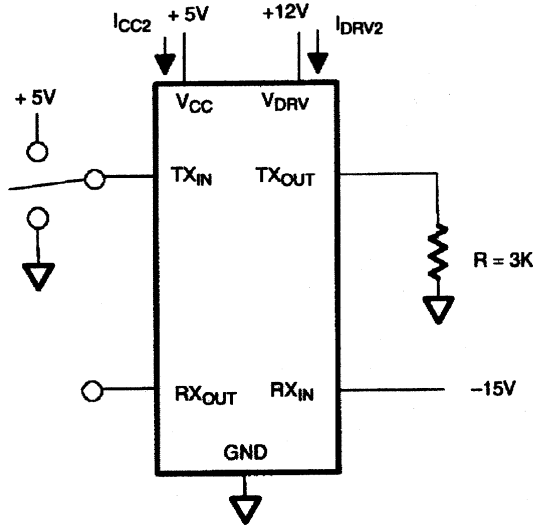



**PROPAGATION DELAY TEST CIRCUIT Figure 7**

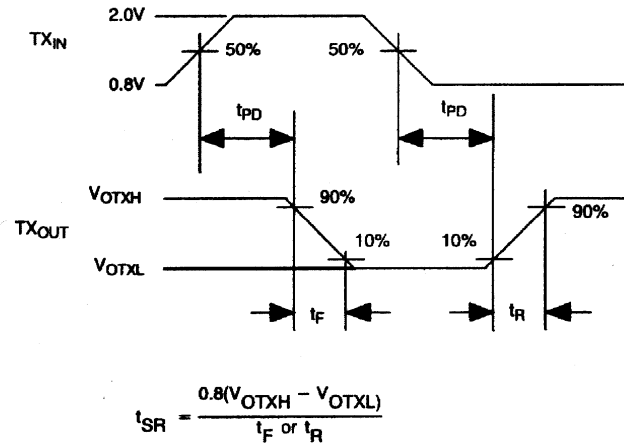
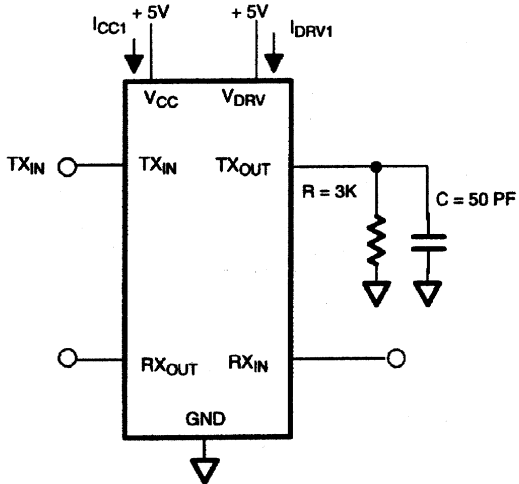

**DS275E 14-PIN TSSOP**

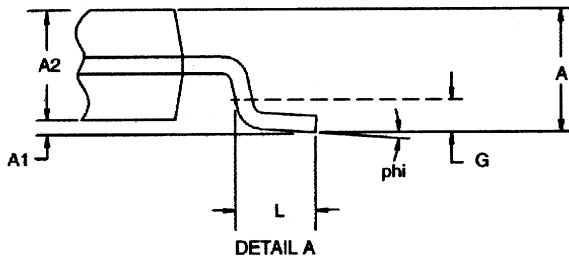
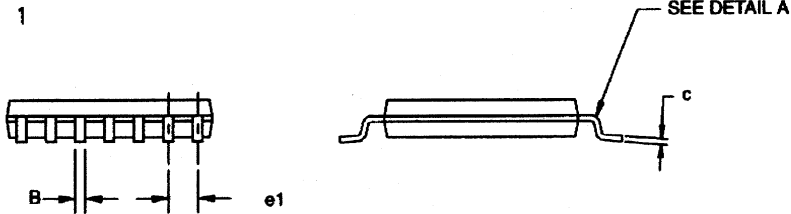
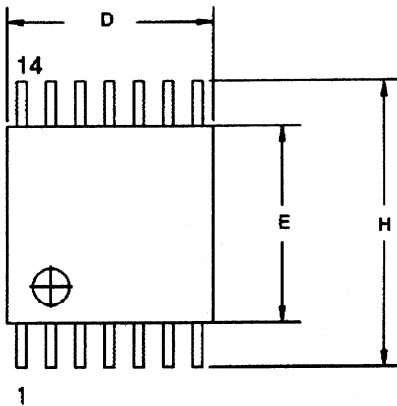

DIM	14-PIN	
	MIN	MAX
A MM	-	1.10
A1 MM	0.05	-
A2 MM	0.75	1.05
B MM	0.18	0.30
C MM	0.09	0.18
D MM	4.90	5.10
E MM	4.40 NOM	
e1 MM	0.65 BSC	
G MM	0.25 REF	
H MM	6.25	6.55
L MM	0.50	0.70
phi	0°	8°