



Chipsmall Limited consists of a professional team with an average of over 10 year of expertise in the distribution of electronic components. Based in Hongkong, we have already established firm and mutual-benefit business relationships with customers from,Europe,America and south Asia,supplying obsolete and hard-to-find components to meet their specific needs.

With the principle of “Quality Parts,Customers Priority,Honest Operation,and Considerate Service”,our business mainly focus on the distribution of electronic components. Line cards we deal with include Microchip,ALPS,ROHM,Xilinx,Pulse,ON,Everlight and Freescale. Main products comprise IC,Modules,Potentiometer,IC Socket,Relay,Connector.Our parts cover such applications as commercial,industrial, and automotives areas.

We are looking forward to setting up business relationship with you and hope to provide you with the best service and solution. Let us make a better world for our industry!



## Contact us

Tel: +86-755-8981 8866 Fax: +86-755-8427 6832

Email & Skype: info@chipsmall.com Web: www.chipsmall.com

Address: A1208, Overseas Decoration Building, #122 Zhenhua RD., Futian, Shenzhen, China



## DS3900H2

## USB HID Communications Module for Evaluation Kits

### General Description

The DS3900H2 evaluation kit (EV kit) component provides bidirectional communication with I<sup>2</sup>C- and SPI-compatible devices using a PC's USB port. In addition, the EV kit can also be used as a general-purpose digital I/O interface with 11 I/O signals that can evaluate a variety of ICs.

The DS3900H2 IC is a small form-factor module that requires appropriate headers to pass communication signals to the device under test. The IC is intended to interface with approved HID-compliant PC software designed by Maxim Integrated. The IC is intended for evaluation purposes only.

### Ev Kit Contents

- Assembled DS3900H2 Circuit Board
- Mini-USB Cable

### Features

- Communicates from PCs to ICs Through a USB Port Using the Human Interface Device (HID) Class
- Fast Communication to I<sup>2</sup>C- and SPI-Compatible Devices
- 11 Total General-Purpose Digital I/O Pins, Including All Communication Protocol Pins
- Built-In Pullup Resistors for SDA and SCL Minimize Required External Hardware
- Connection to Standard Prototyping Boards Possible Using Header Connectors
- Operates from +2.5V to +5.5V
- USB HID Interface for Windows XP®, Windows Vista®, and Windows® 7-Compatible Software
- RoHS Compliant
- Fully Assembled and Tested Proven PCB Layout

*[Ordering Information](#) appears at end of data sheet.*

### DS3900H2 EV Kit Photo

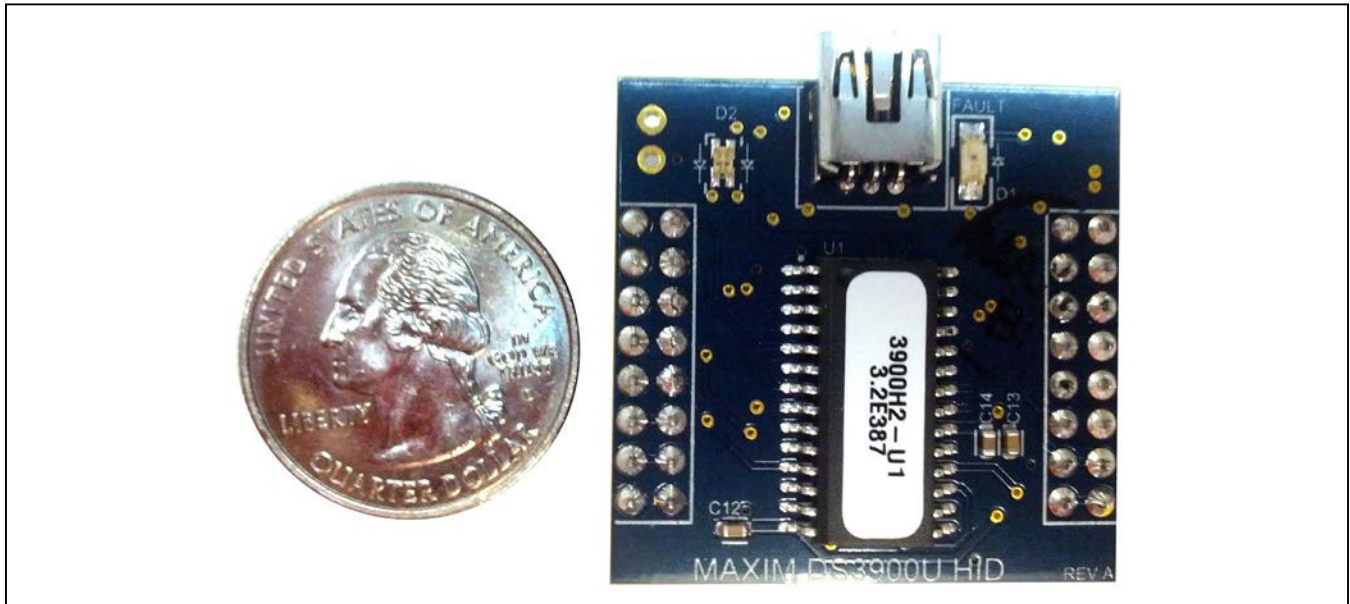

*Windows, Windows XP, and Windows Vista are registered trademarks and registered service marks of Microsoft Corporation.*



## Component List

DESIGNATION	QTY	DESCRIPTION
C1, C6, C7, C13	4	1.0 $\mu$ F ceramic capacitors (0603) TDK CGJ3E2X7R0J105K
C2, C5, C15	3	4.7 $\mu$ F ceramic capacitors (0603) TDK C1608X5R0J475K
C3, C8, C10, C11, C14, C16	6	0.1 $\mu$ F ceramic capacitors (0603) TDK C1608X7R1E104K
C4, C9	2	0.01 $\mu$ F ceramic capacitors (0603) TDK CGJ3E2X7R1C103K
C12	1	220nF ceramic capacitor (0603) TDK C1608X7R1A224K
D1	1	Red LED (1206) Kingbright APTR3216EC
D2	1	Red/green dual LEDs Kingbright APHB M2012SURKCGKC
D3	1	Schottky diode ROHM Semi RB060M-30TR
J1	1	5-pin Mini-USB female connector Molex 54819-0519
J2	0	Do not populate, 2-pin header
J3, J4	2	Create a solder bridge across the two pads
Q1	0	Do not populate, n-channel MOSFET ON Semi NTS4001NT1G

DESIGNATION	QTY	DESCRIPTION
R1, R2	2	25 $\Omega$ $\pm$ 1% resistors (0603) Vishay CRCW060324R9FKEA
R3, R8, R9	3	330 $\Omega$ $\pm$ 1% resistors (0603) Vishay CRCW0603330RFKEA
R4, R5	2	10k $\Omega$ $\pm$ 1% resistors (0603) Vishay CRCW060310K0FKEA
R6	1	100k $\Omega$ $\pm$ 1% resistor (0603) Vishay CRCW0603100KFKEA
R7, R11, R12	3	4.7 k $\Omega$ $\pm$ 1% resistors (0603) Vishay CRCW06034K70FKEA
R10	1	2.2k $\Omega$ $\pm$ 1% resistor (0603) Vishay CRCW06032K20FKEA
U1	1	Microchip PIC18LF2550-I/SO
U2	1	FXMA108 Fairchild FXMA108BQX
U3	1	USB transceiver (16 TSSOP) Maxim MAX3344EEUE+
U4	1	Linear regulator (5 SOT23) Maxim MAX8868EUK33+
U5	1	Current-limit switch (5 SOT70) Maxim MAX4787EXK+
U6	2	16-pin (2 x 8) header (HDR2X8) Sullins PPTC082LFBN-RC
X1	1	4-pin CMOS oscillator AVX KC3225A48.0000C30E00

## Component Suppliers

SUPPLIER	PHONE	WEBSITE
AVX North America	864-967-2150	www.avx.com
Fairchild Semiconductor	888-522-5372	www.fairchildsemi.com
Kingbright Corporation	909-468-0500	www.kingbrightusa.com
Molex	800-786-6539	www.molex.com
ON Semiconductor	602-244-6600	www.onsemi.com
ROHM Co., Ltd.	858-625-3630	www.rohm.com
Sullins Electronics Corp.	760-744-0125	www.sullinselectronics.com
TDK Corp.	847-803-6100	www.component.tdk.com
Vishay	402-563-6866	www.vishay.com

**Note:** Indicate that you are using the DS3900H2 when contacting these component suppliers.

**Quick Start**

**Required Equipment**

- DS3900H2 EV kit hardware (included)
- Mini-USB cable (included)
- User-supplied Windows XP, Windows Vista, or Windows 7 PC with a spare USB port
- User-supplied +2.5V to +5.5V power supply (300mA minimum)
- Approved previously designed HID-compliant GUI designed by Maxim Integrated
- DS3900H2 breakout board or a previously purchased compatible Maxim Integrated Ev kit

**Setup Procedure**

The EV kit communicates with ICs using a PC's USB port. It utilizes a MAX3344E USB transceiver (U3) to convert logic-level signals to USB signals, and USB signals to logic-level signals acceptable for the microprocessor. The microprocessor is then able to communicate to the PC

by using its full-speed-compatible USB serial interface engine. The USB interface of the IC hardware is configured as an HID device and therefore does not require a unique/custom device driver. Once powered and properly connected to a PC through a USB cable, Windows should automatically begin installing the necessary device driver. Once the driver installation is complete, a Windows message appears near the **System Icon** menu indicating that the hardware is ready to use. After the hardware is ready to use, open an approved HID-compliant graphical user interface (GUI) designed by Maxim Integrated. The GUI then sends commands of various lengths over the USB connection. This provides instruction and data for the IC to communicate with the I<sup>2</sup>C- and SPI-compatible devices, or to read or write a specific pin of the IC. All of the pins, with the exception of P3, have three-state drivers. Since the IC is rated to work with supply voltages ranging from +2.5V to +5.5V, the EV kit operates from the same voltage supply as the IC that it is controlling.

**Detailed Description of Hardware**

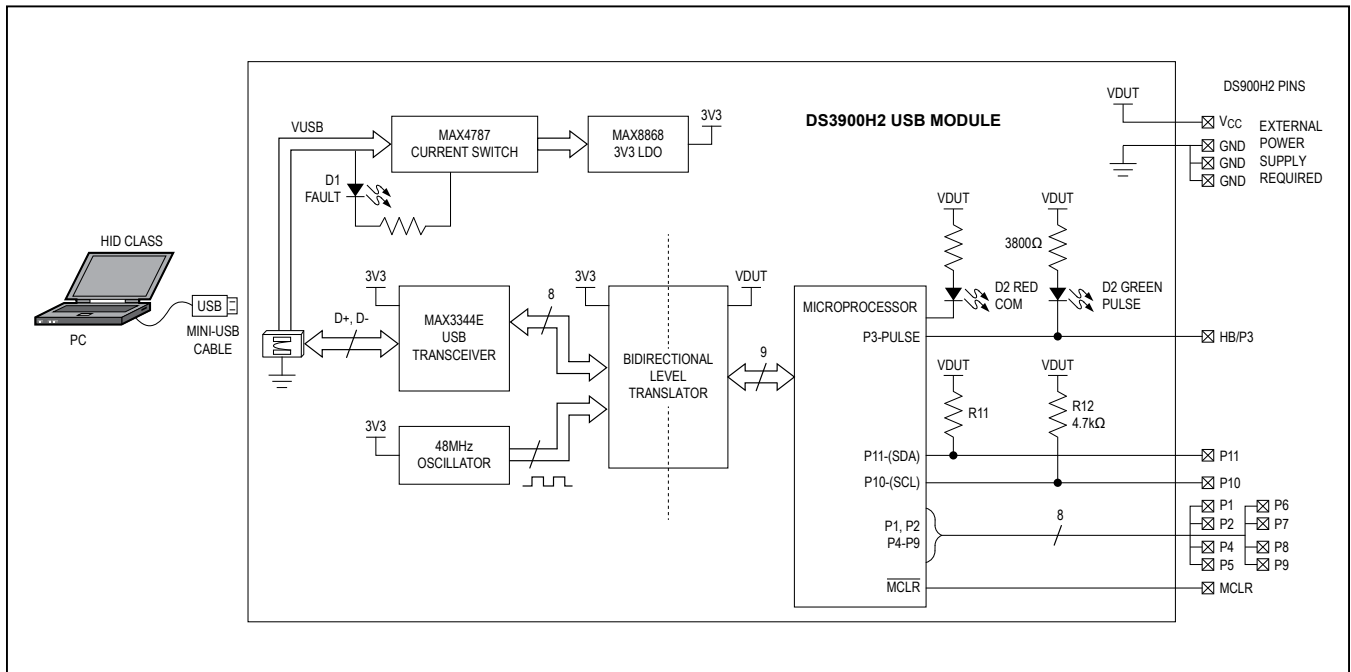

Figure 1. DS3900H2 Functional Diagram

**Table 1. Recommended Operating Conditions**(Typical values are at  $V_{CC} = 3.3V$ ,  $T_A = +25^{\circ}C$ , unless otherwise noted.) (Notes 1 and 2)

PARAMETER	SYMBOL	CONDITIONS	MIN	TYP	MAX	UNITS
Supply Voltage	$V_{CC}$		+2.5		+5.5	V
Supply Current				30		mA
Input Low Voltage	$V_{IL}$	I/O Pins P1–P11			$0.15 \times V_{CC}$	V
Input High Voltage	$V_{IH}$	I/O Pins P1–P11	$0.25 \times V_{CC} + 0.8V$			V
Output High Voltage	$V_{OH}$	I/O Pins P1–P11, $I_{OH} = -3.0mA$	$V_{CC} - 0.7$			V
Output Low Voltage	$V_{OL}$	I/O Pins P1–P11, $I_{OL} = 8.5mA$			+0.6	V
Ambient Temperature	$T_A$		-40		+85	$^{\circ}C$
I2C Clock Frequency			100		400	kHz
SPI Clock Frequency			186	750	3000	kHz

**Note 1:** All voltages listed are with respect to ground.**Note 2:** Devices are only functionally tested; parameters listed not guaranteed.**Table 2. Pin Description**

PIN		FUNCTION
I2C	SPI	
P1, P2, P4, P5, P7, P8		General-purpose bit I/O with three-state I/O pin (input, push-pull output driver).
HB/P3		Pulse or general-purpose bit I/O with open-drain I/O pin (input, open drain) output driver.
P6	—	General-purpose bit I/O with three-state I/O pin (input, push-pull output driver).
—	P6	CE (push-pull output driver when used as CE) or general-purpose bit I/O with three-state I/O pin (input, push-pull output driver).
P9	—	General-purpose bit I/O with three-state I/O pin (input, push-pull output driver).
—	P9	MOSI (push-pull output driver when used as MOSI) or general-purpose bit I/O with three-state I/O pin (input, push-pull output driver).
P10	—	SCL (open-drain output when used as SCL) or general-purpose bit I/O with three-state I/O pin (input, push-pull output driver).
P11	—	SDA (open-drain output or input when used as SDA) or general-purpose bit I/O with three-state I/O pin (input, push-pull output driver).
—	P10	SCK (push-pull output driver when used as SCK) remove built-in pullup resistor R12 or general-purpose bit I/O with three-state I/O pin (input, push-pull output driver).
—	P11	MISO (input when used as MISO) remove built-in pullup resistor R11 or general-purpose bit I/O with three-state I/O pin (input, push-pull output driver).
MCLR		Do not connect (reset for microprocessor).
GND		Ground Terminals. All three ground terminals must be connected to ground for operation.
$V_{CC}$		Power-Supply Terminal. External power supply (VDUT) required.

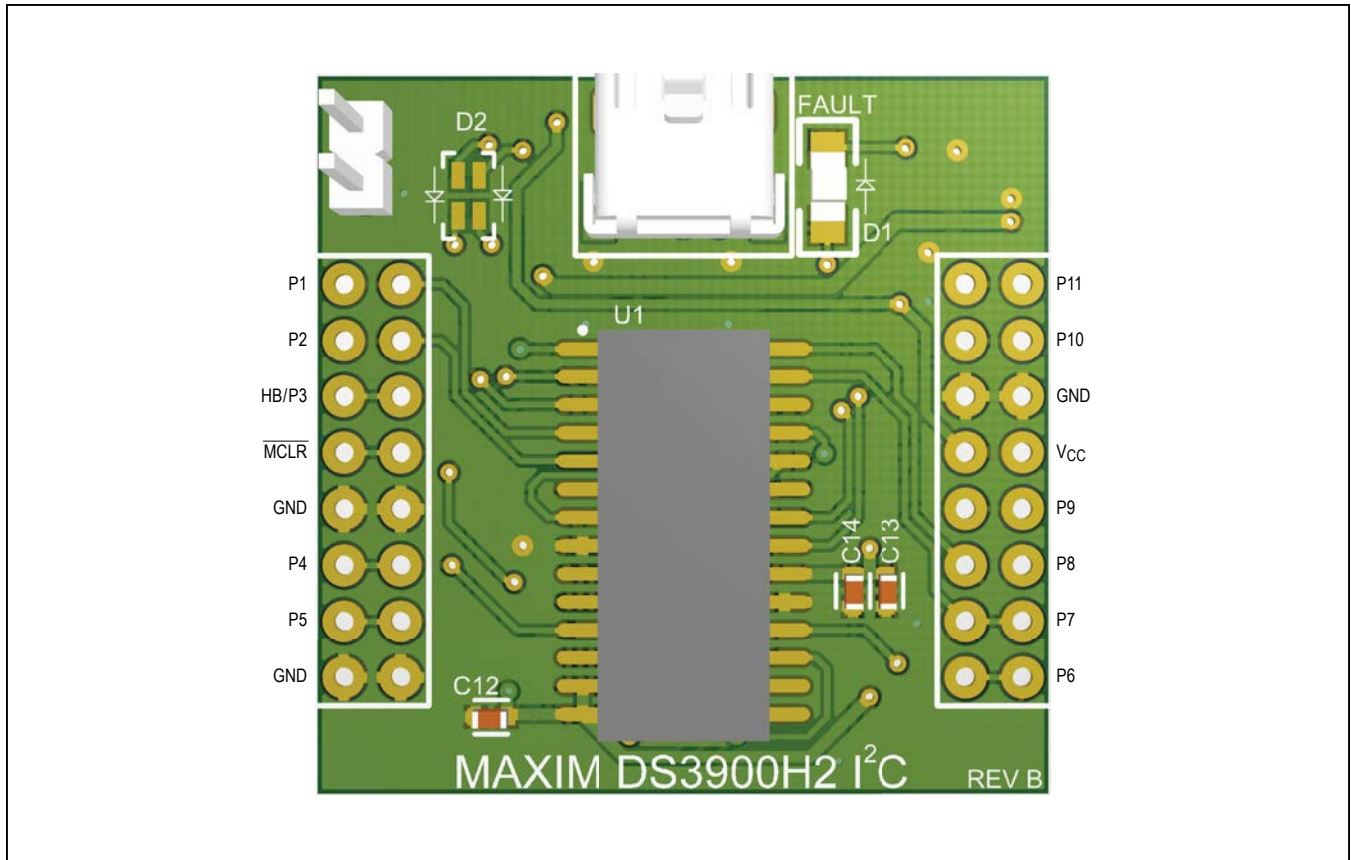

Figure 2. DS3900H2 Pin Configuration

### Designing Hardware to Utilize the Built-In Support for I<sup>2</sup>C Devices

The IC has custom firmware that utilizes either a master synchronous serial port (MSSP) of the microcontroller configured in I<sup>2</sup>C mode, or several bit-banging routines with clock-stretching support. These two modes of operation are configured through the evaluation software. To utilize the I<sup>2</sup>C firmware, connect the SCL bus to P10 and the SDA bus to P11, as shown in Figure 3. The IC has built-in pullup resistors (R11, R12) that connect 4.7k $\Omega$  resistors to both I<sup>2</sup>C buses.

Upon initial power-up, the IC configures itself in I<sup>2</sup>C mode using the MSSP block of the microcontroller at SCL clock speed of 400kHz. Note that most evaluation software

configures the IC to the desired communication protocol upon initial software execution and during all USB reconnects of the IC.

For designs that only use the IC to communicate to I<sup>2</sup>C devices, the following items must be accounted for in the hardware design:

- Place the mating connectors on the circuit board (see Figure 5).
- Connect V<sub>CC</sub> and all three GND ground terminals.
- Connect the SCL bus to pin P10, and the SDA bus to P11 of the IC.
- Drive the IC with evaluation software provided by Maxim Integrated.

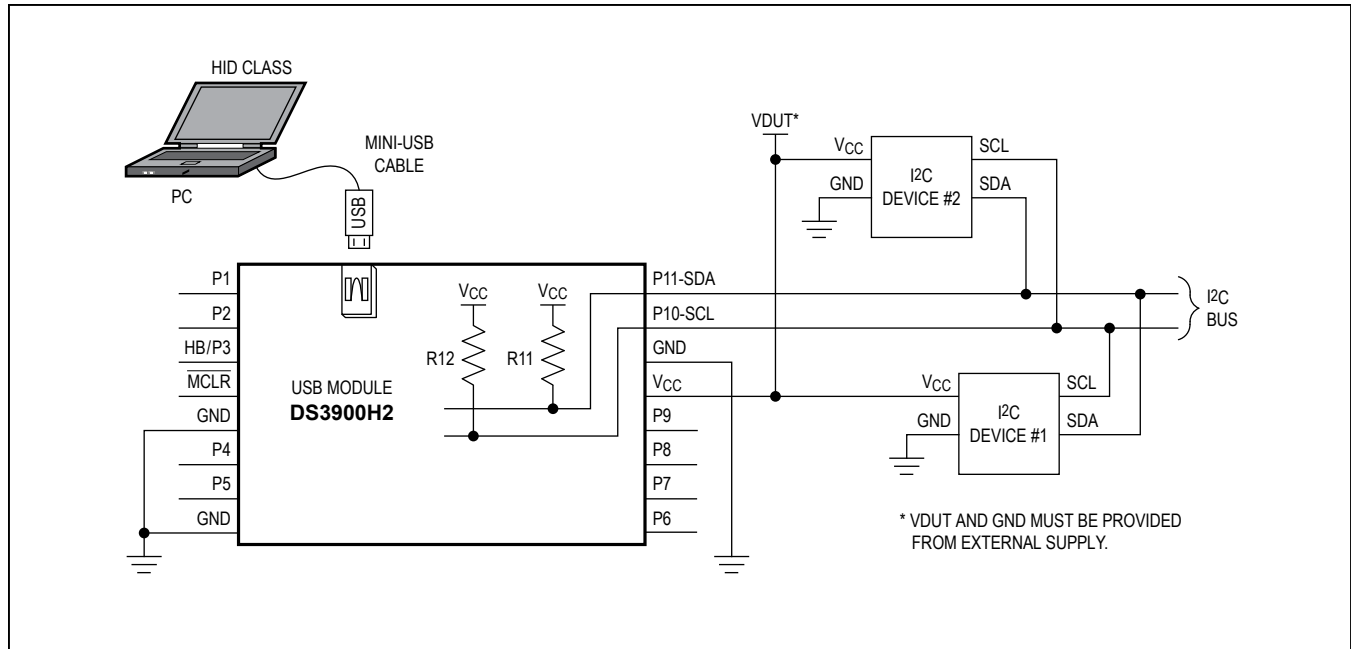

Figure 3. DS3900H2 Typical I<sup>2</sup>C Operating Circuit

### Designing Hardware to Utilize the Built-In Support for SPI Devices

The IC has custom firmware that utilizes a master synchronous serial port (MSSP) of the microcontroller configured in SPI mode, which allows fast communication to SPI devices. To utilize this firmware, connect CE to P6, the MISO bus to P11, the MOSI bus to P9, and the SCK bus to P10, as shown in Figure 3. The IC has built-in pullup resistors (R11, R12) that connect 4.7k $\Omega$  resistors to both MISO and SCK; this is not applicable for SPI communication and must be removed.

For designs that only use the IC to communicate to SPI devices, the following items must be accounted for in the hardware design:

- Place the mating connectors on the circuit board (see Figure 5).
- Connect V<sub>CC</sub> and all three GND ground terminals.
- Connect CE to P6, the MISO bus to P11, the MOSI bus to P9, and the SCK bus to P10 of the IC.
- Remove the built-in pullup resistors (R11, R12).
- Drive the IC with evaluation software provided by Maxim Integrated.

### Designing Hardware to Utilize the General-Purpose Bit I/O Signals

Utilizing the IC for general-purpose bit I/O is equally simple as using it for I<sup>2</sup>C and SPI applications. All the I/O pins with the exception of P3 have three-state outputs. These signals can be written to a 0 or a 1 and can be read as inputs.

P3 has an open-drain output and can be read as an input pin as well; however, its default function is a system pulse that provides a visual indication, through the attached LED, that the IC is operating properly (see Figure 7). The P3 pin defaults to a slow-pulsing output that can be disabled, but designs using P3 for I/O should be conscious that the IC could attempt to blink P3 before the pulse function is disabled. As long as the IC connected to P3 is tolerant of this behavior, P3 can be used as an additional I/O. When using P3 as an I/O pin with the attached LED, writing it to a 1 turns off the pulldown transistor, which turns the LED off, and writing it to a 0 turns the pulldown and the LED on.

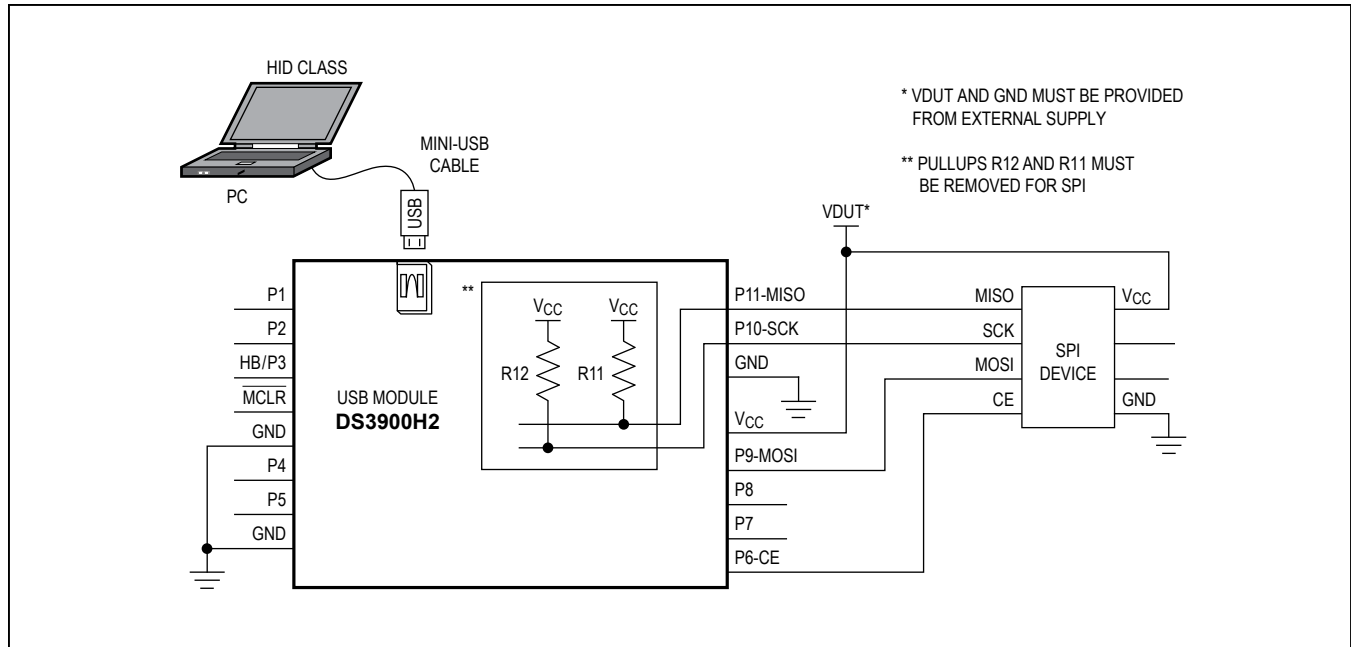

Figure 4. DS3900H2 Typical SPI Operating Circuit

Additionally, designs using P10 and P11 as general I/O should be conscious of the built-in pullup resistors intended for use with I<sup>2</sup>C devices (see Figure 7).

The general procedure for connecting the IC for bit I/O applications is as follows:

- Place the mating connectors on the circuit board (see Figure 5).
- Connect V<sub>CC</sub> and all three GND ground terminals.
- Connect P1 through P11 to the application.
- If the application is using I<sup>2</sup>C devices in addition to the remaining bit I/O signals, make sure to reserve P10 and P11 for the I<sup>2</sup>C application.
- If the application is using SPI devices in addition to the remaining bit I/O signals, make sure to reserve P6, P9–P11 for the SPI application.
- Use P3 only if the application is able to tolerate the pulse function until it is disabled.
- Drive the IC with evaluation software provided by Maxim Integrated.



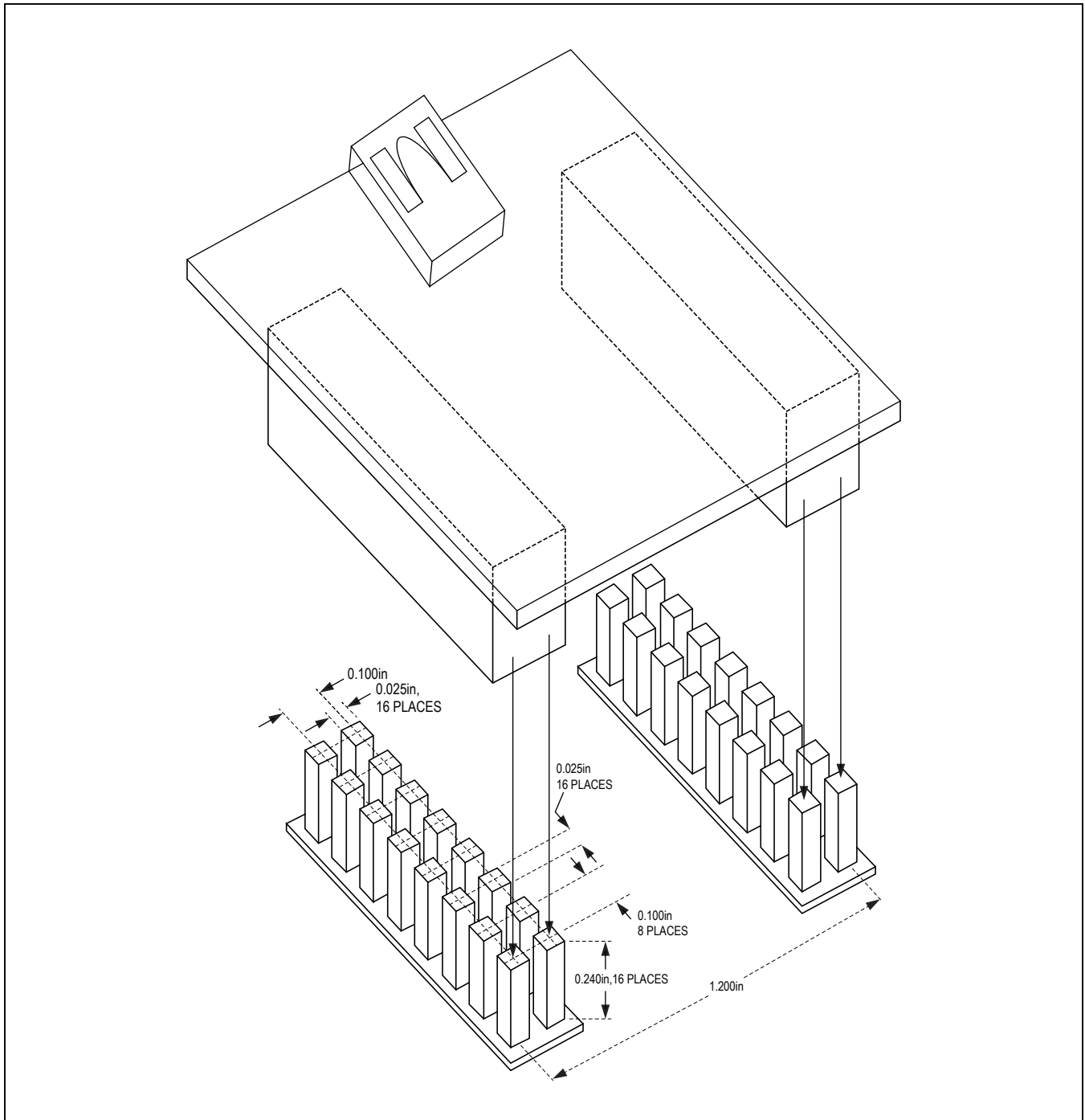

Figure 5. Recommended PCB Connection for DS3900H2

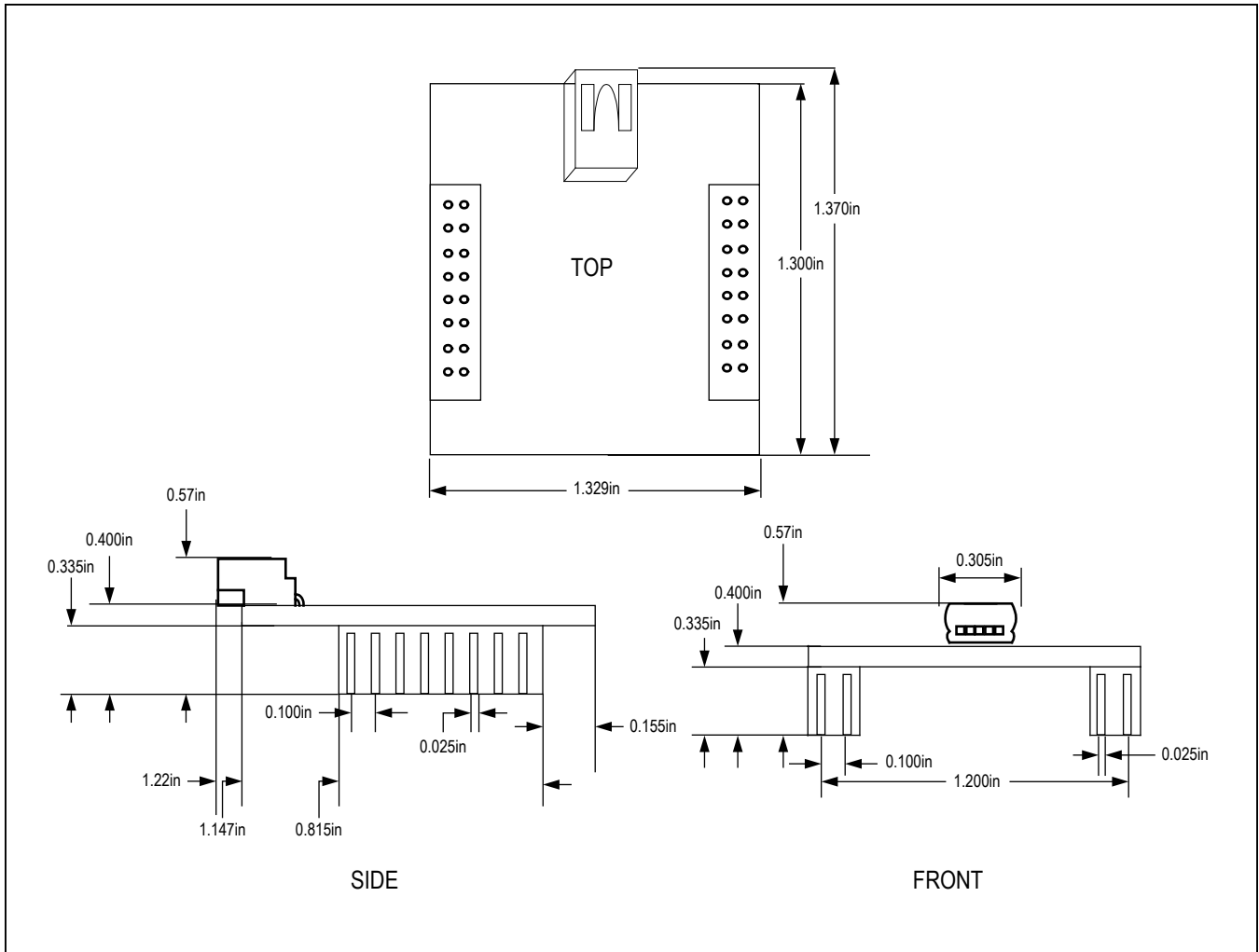

Figure 6. DS3900H2 Dimensions

**Note:** The IC mates with standard 2.54mm (0.100in) 2 x 8 male header connectors. These connectors do not come standard with the board.

**Table 3. Description of LEDs**

LED	COLOR	DESCRIPTION
D1 (FAULT)	Red	<b>USB Power Fault:</b> A fault occurred due to overvoltage limit, current limit, or thermal limit.
D2 (COM)	Red	<b>Communication:</b> After the software has initialized the hardware, the LED flashes red when a command from the PC is received.
	Red and flashing orange	<b>Waiting:</b> Hardware is powered on and waiting for the software to be opened.

**Troubleshooting**

All efforts have been made to ensure that the IC works on the first try, right out of the box. In the rare occasion that

a problem is suspected, see Table 4 to help troubleshoot the issue.

**Table 4. Troubleshooting**

SYMPTOM	CHECK	SOLUTION
Windows does not detect hardware	Is the LED labeled D1 on the DS3900H2 red?	If yes, then the electronic fuse is in a fault state. Inspect for electrical shorts on the PCB and make sure that the PCB is not sitting on a conductive surface.
	USB cable and port	Try connecting the USB cable to a different USB port on the PC and wait for a Windows message that indicates that the hardware is ready to use. If the device is not detected, unplug the USB cable and reboot the PC. Connect the USB cable.
	Are any of the LEDs illuminated?	If not, then the PCB may not be getting power. Make sure bias is applied to $V_{CC}$ and all three GND terminals are connected to system ground. Verify that the USB cable is connected to a PC.

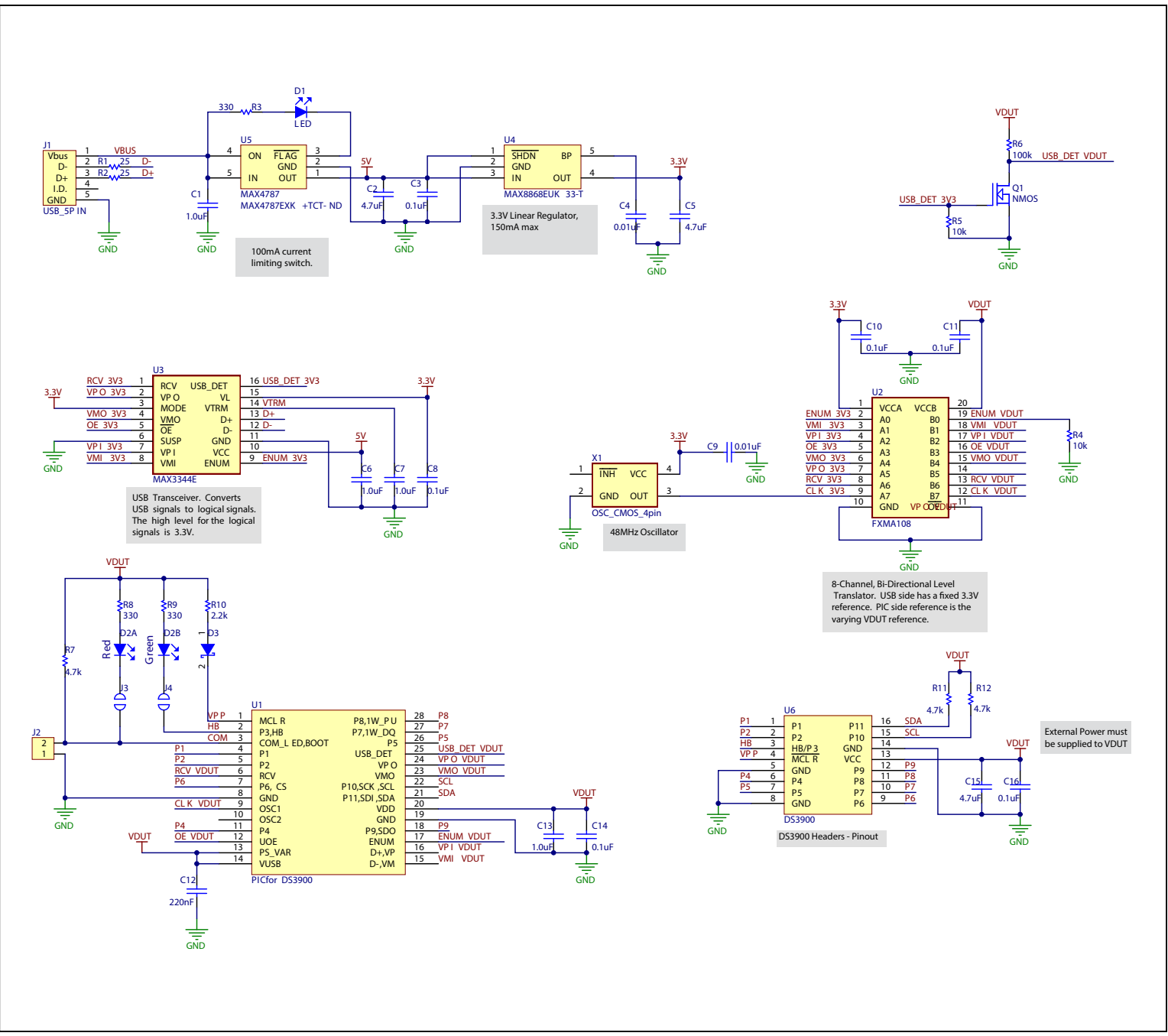

Figure 7. DS3900H2 EV Kit Communications Module Schematic



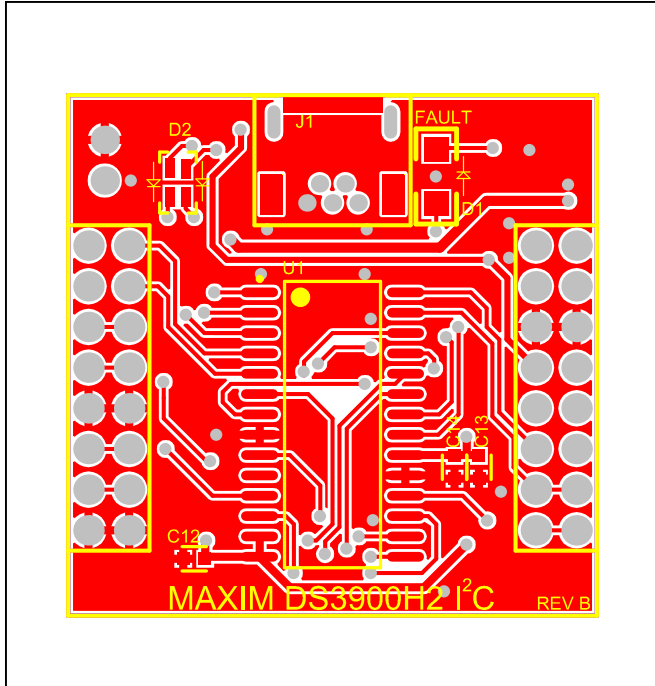

Figure 8. DS3900H2 EV Kit Communications Module PCB Layout—Top

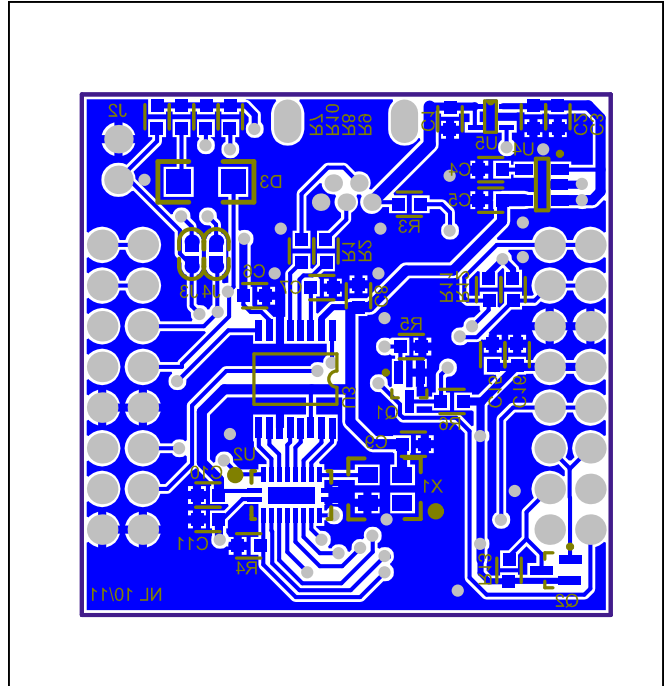

Figure 9. DS3900H2 EV Kit Communications Module PCB Layout—Bottom

**DS3900H2 Revisions**

Revisions yielding significant changes and/or improvements are tracked in firmware and displayed in most evaluation software provided by Maxim Integrated. Revisions are broken up into a major and minor revision. For example, if the DS3900H2’s revision is 3.2, it returns a major revision of 3 and a minor revision of 2. Knowing the revision allows the software to both utilize new functions that are not available in previous versions of the DS3900H2’s firmware and to avoid using commands that are not present in prior versions. Although there are no plans to change the firmware at this time, Maxim Integrated reserves the right to change the firmware at any time without notice.

**Intended Use**

The DS3900H2 module is intended only to be used to evaluate Maxim Integrated’s circuits. All hardware, firmware, and any relative software is provided “as is,” without warranty of any kind, express or implied, including but not limited to the warranties of merchantability, fitness for a particular purpose, and noninfringement. In no event shall Maxim Integrated be liable for any claim, damages or other liability, whether in an action of contract, tort or otherwise, arising from, out of, or in connection with the hardware, firmware, and any relative software or the use or other dealings in the hardware, firmware, and any relative software.

## Ordering Information

PART	TYPE
DS3900H2EVKIT#	EV Kit Communications Module

*#Denotes an RoHS-compliant device that may include lead(Pb), which is exempt under the RoHS requirements.*

## Revision History

REVISION NUMBER	REVISION DATE	DESCRIPTION	PAGES CHANGED
0	6/13	Initial release	—

For pricing, delivery, and ordering information, please contact Maxim Direct at 1-888-629-4642, or visit Maxim Integrated's website at [www.maximintegrated.com](http://www.maximintegrated.com).

*Maxim Integrated cannot assume responsibility for use of any circuitry other than circuitry entirely embodied in a Maxim Integrated product. No circuit patent licenses are implied. Maxim Integrated reserves the right to change the circuitry and specifications without notice at any time.*