



Chipsmall Limited consists of a professional team with an average of over 10 year of expertise in the distribution of electronic components. Based in Hongkong, we have already established firm and mutual-benefit business relationships with customers from,Europe,America and south Asia,supplying obsolete and hard-to-find components to meet their specific needs.

With the principle of "Quality Parts,Customers Priority,Honest Operation,and Considerate Service",our business mainly focus on the distribution of electronic components. Line cards we deal with include Microchip,ALPS,ROHM,Xilinx,Pulse,ON,Everlight and Freescale. Main products comprise IC,Modules,Potentiometer,IC Socket,Relay,Connector.Our parts cover such applications as commercial,industrial, and automotives areas.

We are looking forward to setting up business relationship with you and hope to provide you with the best service and solution. Let us make a better world for our industry!



## Contact us

Tel: +86-755-8981 8866 Fax: +86-755-8427 6832

Email & Skype: info@chipsmall.com Web: www.chipsmall.com

Address: A1208, Overseas Decoration Building, #122 Zhenhua RD., Futian, Shenzhen, China





## DS9481R USB-to-1-Wire/iButton Adapter

### Evaluates: 1-Wire Slave and iButton Devices

#### General Description

The DS9481R is a USB-to-1-Wire® adapter for easy PC connectivity to 1-Wire devices. The adapter provides an RJ11 connector with the signals to communicate with all 1-Wire and iButton® devices that support a 3.3V data I/O level. Additionally, the adapter provides the support and signaling to program 1-Wire/iButton EEPROM and one-time programmable (OTP)/EPROM devices. To provide a total hardware solution, the DS9481R can readily be used with the DS9120 socket adapter to create a 1-Wire PC programmer for 1-Wire slave devices (contact factory for more information). The equivalent slave hardware solution for the iButton is the DS1402D-DR8.

#### Adapter Contents

| QTY | DESCRIPTION   |
|-----|---|
| 1   | USB-to-1-Wire adapter<br>Maxim DS9481R-3C7+                                 |
| 1   | USB Type A-to-USB Mini-Type B cable<br>Qualtek Electronics Corp. 3021003-03 |

#### Features

- ◆ Driver Support for Windows® 7, Windows Vista®, and Windows XP® Operating Systems
- ◆ Enumerates as a Virtual PC COM Port by Use of the Prolific PL-2303HXD USB-to-UART Bridge IC
- ◆ Emulates the DS2480B 1-Wire Line Driving Functionality
- ◆ 1-Wire OTP/EPROM Programming Provided Without the Need of an External Power Supply (12V on OW, 7V on PULSE)
- ◆ 3.3V Read/Write Operation to 1-Wire/iButton Devices
- ◆ RJ11 Interface for Standard Connectivity Accessories such as the DS9120 Socket Adapter
- ◆ Supports Standard and Overdrive 1-Wire Communication
- ◆ Provides Strong Pullup to 3.3V
- ◆ Fully Compliant with USB 2.0 Specification
- ◆ Windows XP Certified Logo Drivers

#### Ordering Information

| PART         | TYPE    |
|--------------|---------|
| DS9481R-3C7+ | Adapter |

+ Denotes lead(Pb)-free and RoHS compliant.

### DS9481R USB-to-1-Wire/iButton Adapter



1-Wire and iButton are registered trademarks of Maxim Integrated Products, Inc.  
Windows, Windows Vista, and Windows XP are registered trademarks of Microsoft Corp.

For pricing, delivery, and ordering information, please contact Maxim Direct at 1-888-629-4642, or visit Maxim's website at [www.maximintegrated.com](http://www.maximintegrated.com).

# DS9481R USB-to-1-Wire/iButton Adapter

## Evaluates: 1-Wire Slave and iButton Devices

### Component List

| DESIGNATION           | QTY | DESCRIPTION   |
|-----------------------|-----|---|
| C1, C6, C21           | 3   | 4.7 $\mu$ F, 16V Y5V ceramic capacitors (0805)<br>TDK Corp. C2012Y5V1C475Z            |
| C2, C3                | 2   | 2.2 $\mu$ F, 16V Y5V ceramic capacitors (0805)<br>Murata GRM21BF51C225ZA01L           |
| C4, C7                | 2   | 0.22 $\mu$ F $\pm$ 10%, 16V X7R ceramic capacitors (0603)<br>TDK Corp. C1608X7R1C224K |
| C5, C15, C22          | 3   | 10nF $\pm$ 5%, 16V X7R ceramic capacitors (0603)<br>AVX 06035C103JAT2A                |
| C8, C11–C14, C20, C23 | 7   | 0.1 $\mu$ F, 16V X7R ceramic capacitors (0603)<br>KEMET C0603C104K4RACTU              |
| C10                   | 1   | 10 $\mu$ F, 10V Y5V ceramic capacitor (0805)<br>TDK Corp. C2012Y5V1C106Z              |
| C16                   | 0   | Do not populate,<br>470pF ceramic capacitor (0603)                                    |
| C17                   | 1   | 1 $\mu$ F, 10V X7R ceramic capacitor (0603)<br>Taiyo Yuden LMK107B7105KA-T            |
| C19                   | 1   | 10pF, 16V NP0 ceramic capacitor (0603)<br>TDK Corp. C1608C0G1H100D                    |
| C9, C24, C25          | 0   | Do not populate, capacitors   |
| CN1                   | 1   | USB Mini-AB connector, right-angle, SMD, 5-position<br>JAE Electronics DX3R005HN2E700 |
| D1                    | 1   | 30V, 200mA Schottky diode (SOT23)<br>Diodes Inc./Zetex BAT54TA                        |
| D2                    | 1   | 15V, 350mA zener diode (SOT23)<br>Diodes Inc. MMBZ5245B-7-F                           |
| D3                    | 1   | Orange LED (TSS type) (0603)<br>Panasonic/SSG LNJ812R83RA                             |
| D4                    | 1   | Dual CC Schottky diode (SOT23)<br>Diodes Inc./Zetex BAT54CTA                          |

| DESIGNATION                 | QTY | DESCRIPTION   |
|-----------------------------|-----|---|
| FB1, FB2                    | 2   | 220 $\Omega$ , 2000mA ferrite chips (0805)<br>Murata BLM21PG221SN1D               |
| J1                          | 1   | 6-position, right-angle, PCB-mounted jack<br>Tyco 5520425-3                       |
| J2                          | 0   | Do not populate,<br>JTAG connector  |
| Q1, Q3                      | 2   | 130mA, 50V p-channel MOSFETs (SOT23-3)<br>Fairchild Semiconductor BSS84           |
| Q2, Q4, Q5, Q7              | 4   | 115mA, 60V n-channel MOSFETs (SOT23)<br>Diodes, Inc. 2N7002-7-F                   |
| Q6                          | 1   | 3.9A, 20V p-channel MOSFET (SOT23)<br>NXP PMV65XP,215                             |
| R1, R29                     | 0   | Do not populate, resistors  |
| R2, R3, R5                  | 3   | 27 $\Omega$ $\pm$ 1%, 1/10W SMD resistors (0603)<br>Yageo RC0603FR-0727RL         |
| R4, R16, R21                | 3   | 1.5k $\Omega$ $\pm$ 1%, 1/10W SMD resistors (0603)<br>Panasonic ECG ERJ-3EKF1501V |
| R6, R24                     | 2   | 10k $\Omega$ $\pm$ 1%, 1/10W SMD resistors (0603)<br>Yageo RC0603FR-0710KL        |
| R7, R14, R26                | 3   | 1k $\Omega$ $\pm$ 1%, 1/10W SMD resistors (0603)<br>Yageo RC0603FR-071KL          |
| R8, R13, R17, R20, R27, R30 | 5   | 100k $\Omega$ $\pm$ 1%, 1/10W SMD resistors (0603)<br>Yageo RC0603FR-07100KL      |
| R9                          | 1   | 750 $\Omega$ $\pm$ 5%, 1/10W SMD resistor (0603)<br>Yageo RC0603FR-07750RL        |
| R10                         | 1   | 0 $\Omega$ $\pm$ 1%, 1/10W SMD resistor (0603)<br>Panasonic ECG ERJ-3GEY0R00V     |

# **DS9481R USB-to-1-Wire/iButton Adapter**

## **Evaluates: 1-Wire Slave and iButton Devices**

### **Component List (continued)**

| DESIGNATION   | QTY | DESCRIPTION   |
|---------------|-----|---|
| R11           | 1   | 33Ω ±1%, 0.1W SMD resistor (0603)<br>Rohm MCR03EZPFX33R0                          |
| R12, R15, R22 | 3   | 4.99Ω ±1%, 1/10W SMD resistors (0603)<br>Yageo RC0603FR-074R99L                   |
| R18           | 1   | 2.2kΩ ±5%, 1/10W SMD resistor (0603)<br>Stackpole Electronics RMCF 1/16 2.2K 1% R |
| R23           | 1   | 51kΩ ±0.1%, 1/10W SMD resistor (0603)<br>Panasonic ECG ERA-3AEB513V               |
| R25           | 1   | 11kΩ ±0.1%, 1/10W SMD resistor (0603)<br>Vishay/Dale<br>TNPW060311K0BEEA          |
| R28           | 1   | 10Ω ±1%, 1/10W SMD resistor (0603)<br>Yageo RC0603FR-0710RL                       |
| R31           | 1   | 32.4kΩ ±1%, 1/10W SMD resistor (0603)<br>Vishay/Dale<br>TNPW060332K4BEEA          |
| R32           | 1   | 30.1kΩ ±0.1%, 1/10W SMD resistor (0603)<br>Panasonic ECG ERJ-3EKF3012V            |
| R33           | 1   | 50kΩ ±1%, 1/10W SMD resistor (0603)<br>Panasonic ECG ERJ-3EKF4992V                |
| RT1           | 1   | 0.12A, 30V PTC resettable fuse (1206)<br>Bourns MF-NSMF012-2                      |

| DESIGNATION | QTY | DESCRIPTION   |
|-------------|-----|---|
| SW1         | 0   | Do not populate, switch   |
| U1          | 1   | Low-dropout, 300mA linear regulator (5 SOT23)<br>Maxim MAX8887EZK33+T (Top Mark: ADPZ)    |
| U2          | 1   | 12V, 30mA Flash memory programming supply (8 SO)<br>Maxim MAX662ACSA+                     |
| U3          | 1   | TinyLogic® UHS inverter (5 SOT23)<br>Fairchild NC7SZ04M5X                                 |
| U4          | 0   | Do not populate, Silicon oscillator (3 SC70)<br>Maxim MAX7381AXR126-T                     |
| U5          | 1   | USB-to-serial bridge controller (28 SSOP)<br>Prolific PL-2303HXD SSOP                     |
| U6          | 1   | 16-bit microcontroller with infrared module (32 TQFN-EP*)<br>Maxim MAXQ610A-9410+         |
| U7          | 1   | 2-channel ESD protector (6 μDFN)<br>Maxim MAX13204EALT+ (Top Mark: BV)                    |
| U8          | 1   | High-voltage, low-power linear regulators (5 SOT23)<br>Maxim MAX1616EUK+ (Top Mark: ABZD) |
| U9          | 1   | 1.8V comparator (5 SOT23)<br>STMicroelectronics TS3021ILT                                 |
| —           | 1   | PCB: DS9481R REV A3   |

\*EP = Exposed pad.

TinyLogic is a registered trademark of Fairchild Semiconductor.

# **DS9481R USB-to-1-Wire/iButton Adapter**

## **Evaluates: 1-Wire Slave and iButton Devices**

### **Quick Start**

#### **Recommended Equipment**

- Maxim DS9481R (included in adapter)
- USB type-A to USB Mini type-B cable (included in adapter)
- RJ11 cable assembly (not included)
- PC with a Windows 7, Windows Vista, or Windows XP OS and a spare USB port

**Note:** In the following sections, software-related items are identified by bolding. Text in **bold** refers to items directly from the adapter software. Text in **bold and underlined** refers to items from the Windows operating system.

#### **Procedure**

- 1) Do the following to install the PL-2303HXD Prolific driver:
  - a) Download either the driver file called PL2303\_Prolific\_DriverInstaller\_v130.ZIP or the latest version from <http://www.prolific.com.tw/eng/downloads.asp?ID=31>.
  - b) **Open** and **Run** either the file called PL2303\_Prolific\_DriverInstaller\_v110.EXE or the latest version.
  - c) Follow the directions of the **Install Wizard** until **Finish** is reached for the PL-2303 USB-to-serial driver installation. Close by clicking the **Finish** button.
- 2) Do the following to install the 1-Wire drivers:
  - a) Go to the 1-Wire Drivers—Getting Started webpage at [www.maximintegrated.com/1-wiredrivers](http://www.maximintegrated.com/1-wiredrivers).
  - b) Click on the **Click to go to Download Page** button.
  - c) From the **Choose Operating System** drop-down list, select your OS.
  - d) From the **Select File** drop-down list, select 32-bit or 64-bit 1-Wire drivers for the architecture being used by your OS.
  - e) Click the **Download** button.
  - f) When prompted by the question **Do you want to run or save this file?**, select **Run**.
  - g) When you get a security warning that says **Do you want to run the software?**, select **Run**.
  - h) Read and check the box if you accept the license agreement and click **Install**.
  - i) Click the **Finish** button to exit the Setup Wizard.
- 3) The DS9481R USB-to-1-Wire adapter uses both the Prolific PL-2303HXD and the Maxim MAXQ610 to emulate a virtual COM-to-1-Wire port on any PC. Find the enumeration of the virtual COM port by inserting the DS9481R into a spare USB port on the computer. Determine the COM port by looking in **Control Panel**→**System**→**Hardware**→**Device Manager** and



Figure 1. DS9481R USB-to-1-Wire/iButton Adapter and Cable

# **DS9481R USB-to-1-Wire/iButton Adapter**

## **Evaluates: 1-Wire Slave and iButton Devices**

expand **Ports (COM & LPT)**. The port is COM2 in the example shown in Figure 2.

You have now completed the installation of the DS9481R adapter. Obtain the adapter software and directions for installation for your 1-Wire/iButton slave device

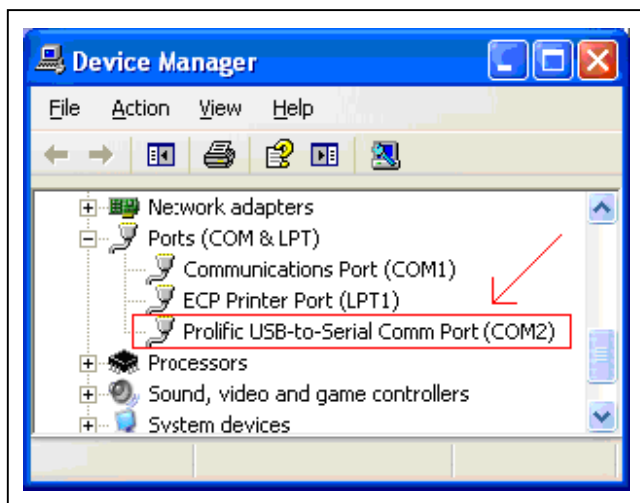

Figure 2. DS9481R COM Port

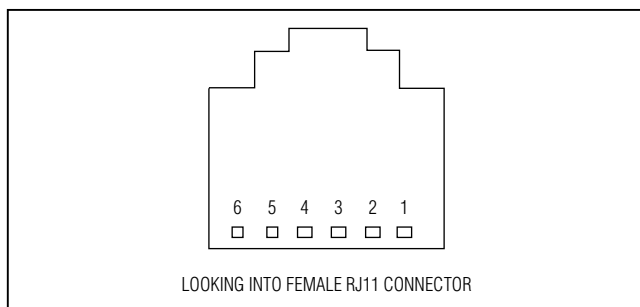

Figure 3. 1-Wire RJ11 Port

**Table 1. 1-Wire RJ11 Pinout**

| CONNECTOR PIN | SIGNAL NAME |
|---------------|-------------|
| 1             | 3.3V        |
| 2             | GND         |
| 3             | OW (DATA)   |
| 4             | OWGND       |
| 5             | PULSE       |
| 6             | GP          |

by contacting Maxim online technical support at <https://support.maximintegrated.com/1-Wire>.

### **Detailed Description of Connectors**

#### **RJ11 Pinout**

Table 1 and Figure 3 show the RJ11 pinout mounted on the DS9481R PCB at J1. The RJ11 pin 1 can supply 3.3V and can be used for auxiliary board power. The GND is the ground of the 3.3V supply. The signal OW (DATA) stands for the 1-Wire data bus. The ground return for OW (DATA) is the signal OWGND. The PULSE signal is to be used as the VCC power supply for OTP 1-Wire slave parts. The PULSE signal is typically 3.3V, but also can provide the needed programming pulse for OTP parts. The GP signal is reserved for future general-purpose usage and is functionally not used by the DS9481R.

#### **Mini-USB Pinout**

The 5-position Mini-USB type AB connector is mounted at CN1 of the DS9481R PCB, as shown in Table 2.

### **Hardware/Firmware Capabilities**

The DS9481R uses both the Prolific PL-2303HXD and the Maxim MAXQ610. The PL-2303HXD is fully compliant with USB 2.0 specification for Windows 7, Windows Vista, and Windows XP OS and provides a bridge for the USB-to-UART connection. The MAXQ610 is loaded with firmware that emulates the functionality of the DS2480B serial-to-1-Wire line driver at a lower 3.3V operation voltage. The MAXQ610 functions as a UART-to-1-Wire bridge and can serve custom application needs with firmware programmability.

**Table 2. Mini-USB Type AB USB Pinout**

| CONNECTOR PIN | SIGNAL NAME |
|---------------|-------------|
| 1             | 5.0V        |
| 2             | DMCN        |
| 3             | DPCN        |
| 4             | NC          |
| 5             | GND         |
| 6-9           | GND_EARTH   |

# DS9481R USB-to-1-Wire/iButton Adapter

## Evaluates: 1-Wire Slave and iButton Devices

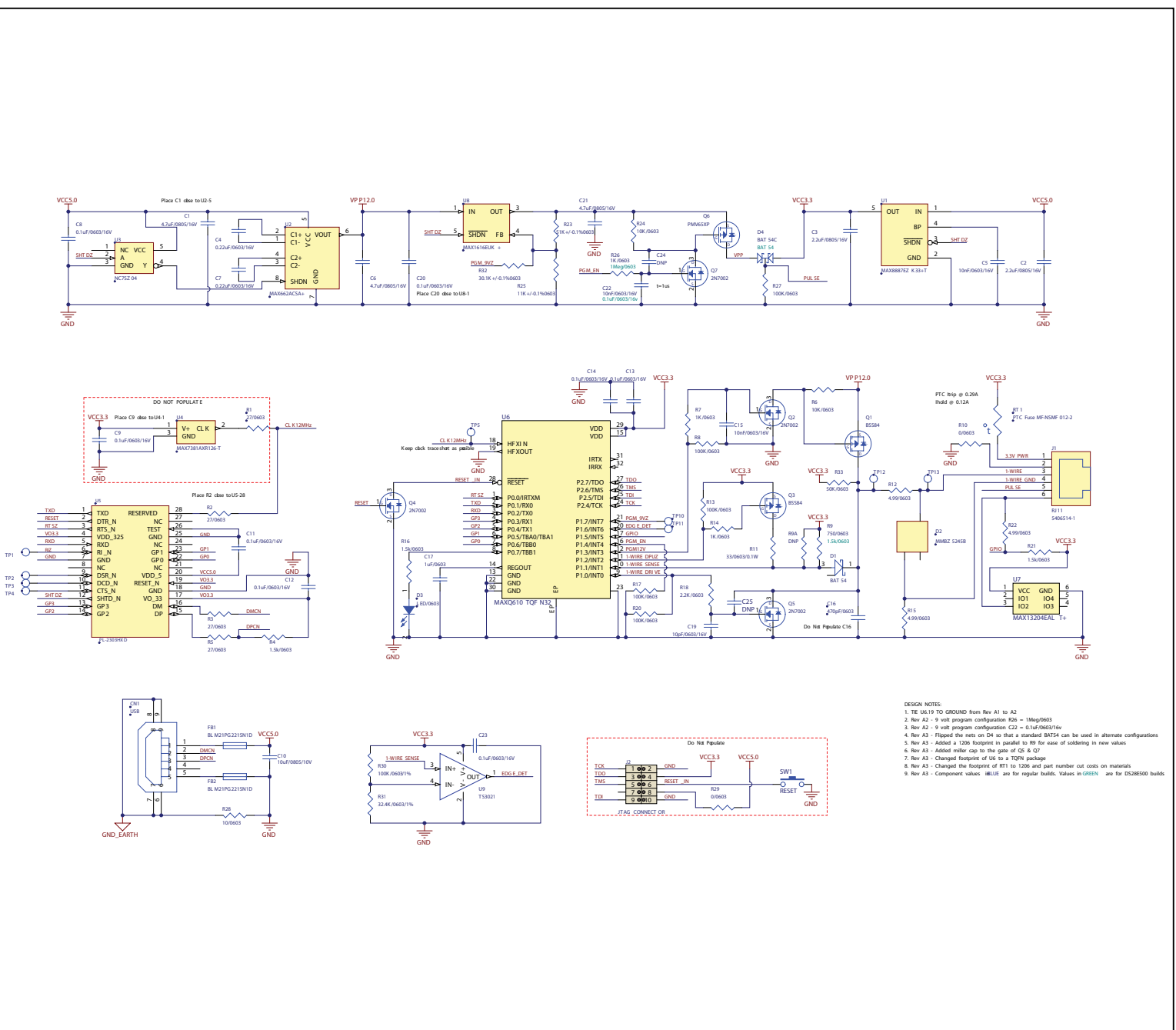

Figure 4. DS9481R Adapter Board Schematic

# **DS9481R USB-to-1-Wire/iButton Adapter** **Evaluates: 1-Wire Slave and iButton Devices**

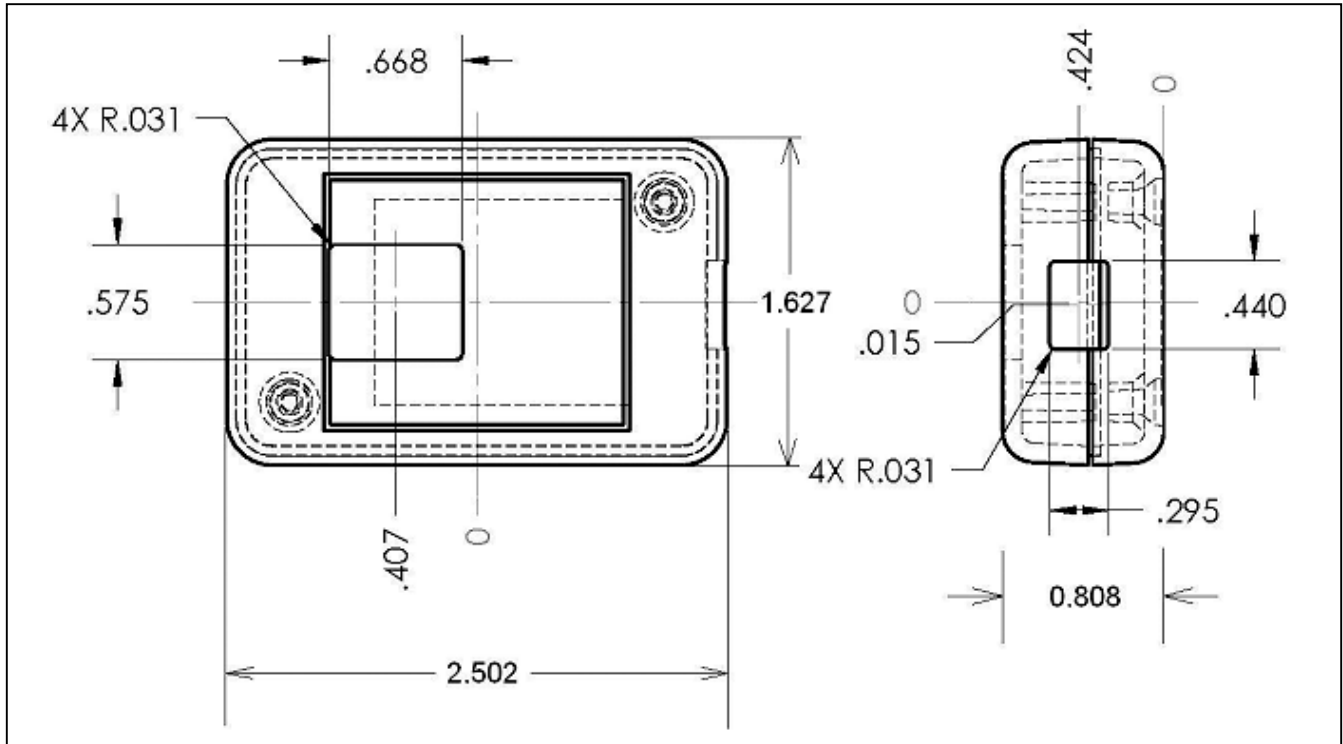

Figure 5. DS9481R Adapter Enclosure Dimensions



# DS9481R USB-to-1-Wire/iButton Adapter

## Evaluates: 1-Wire Slave and iButton Devices

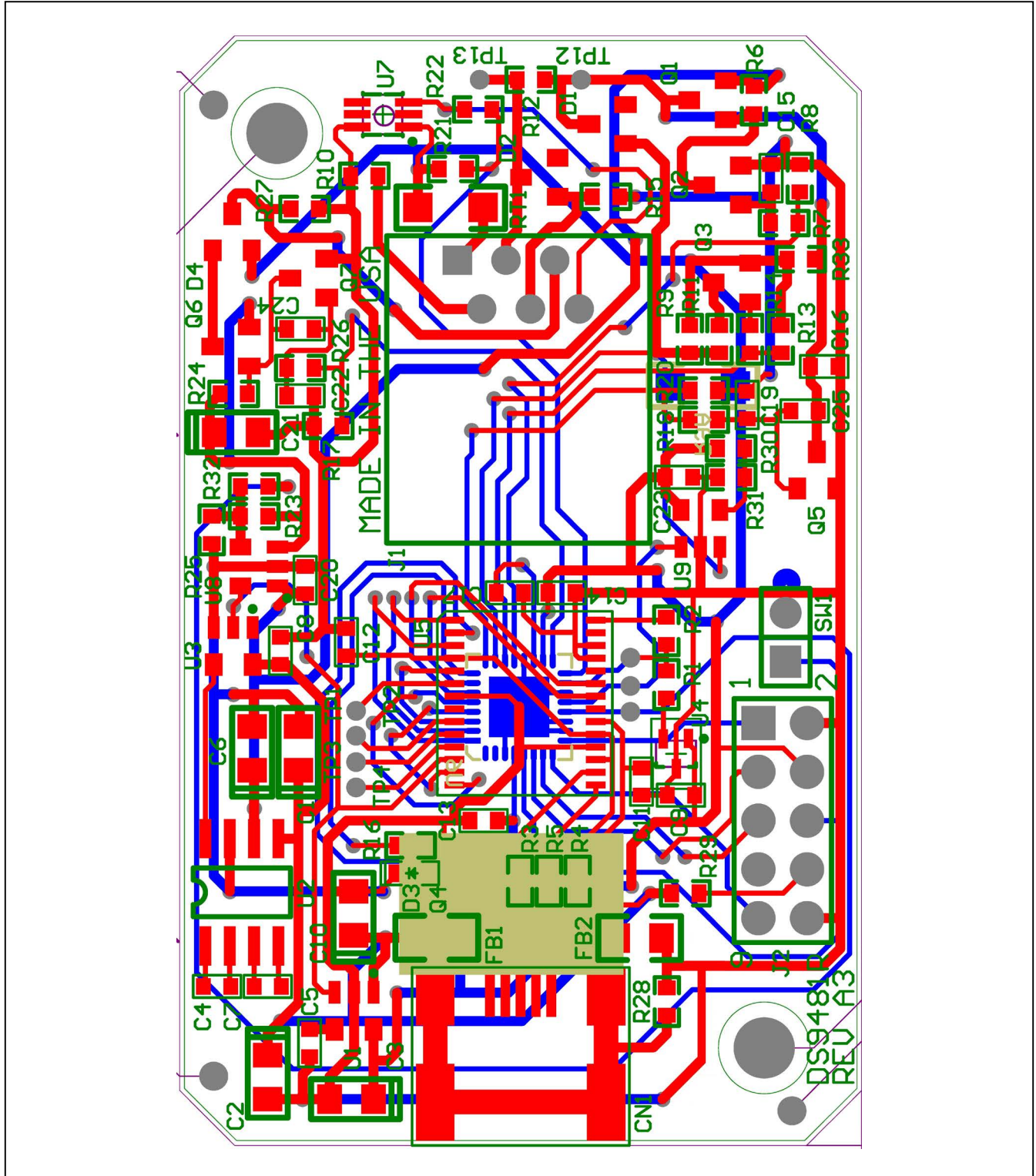

Figure 6. DS9481R Adapter Board—Composite Layout

# **DS9481R USB-to-1-Wire/iButton Adapter**

## **Evaluates: 1-Wire Slave and iButton Devices**

### **Revision History**

| <b>REVISION NUMBER</b> | <b>REVISION DATE</b> | <b>DESCRIPTION</b> | <b>PAGES CHANGED</b> |
|------------------------|----------------------|--------------------|----------------------|
| 0                      | 10/10                | Initial release    | —                    |



*Maxim Integrated cannot assume responsibility for use of any circuitry other than circuitry entirely embodied in a Maxim Integrated product. No circuit patent licenses are implied. Maxim Integrated reserves the right to change the circuitry and specifications without notice at any time.*

**Maxim Integrated 160 Rio Robles, San Jose, CA 95134 USA 1-408-601-1000**

9