



Chipsmall Limited consists of a professional team with an average of over 10 year of expertise in the distribution of electronic components. Based in Hongkong, we have already established firm and mutual-benefit business relationships with customers from,Europe,America and south Asia,supplying obsolete and hard-to-find components to meet their specific needs.

With the principle of “Quality Parts,Customers Priority,Honest Operation,and Considerate Service”,our business mainly focus on the distribution of electronic components. Line cards we deal with include Microchip,ALPS,ROHM,Xilinx,Pulse,ON,Everlight and Freescale. Main products comprise IC,Modules,Potentiometer,IC Socket,Relay,Connector.Our parts cover such applications as commercial,industrial, and automotives areas.

We are looking forward to setting up business relationship with you and hope to provide you with the best service and solution. Let us make a better world for our industry!



Contact us

Tel: +86-755-8981 8866 Fax: +86-755-8427 6832

Email & Skype: info@chipsmall.com Web: www.chipsmall.com

Address: A1208, Overseas Decoration Building, #122 Zhenhua RD., Futian, Shenzhen, China



DS9490R/DS9490B USB to 1-Wire/iButton Adapters

FEATURES

- High-Speed 12Mbps Universal Serial Bus (USB) Interface
- Supports Standard and Overdrive 1-Wire® Communication
- Slew-Rate-Controlled 1-Wire Timing and Active Pullup for Improved 1-Wire Network Performance
- DS9490R has an RJ11 Interface for Standard Connectivity Accessories such as the DS1402D-DR8
- DS9490B has an iButton® Interface and Retains a Fixed iButton
- Built-In Custom DS2401 Identification Chip
- Reads all 1-Wire and iButton Devices. Writes All Except EPROM 1-Wire/iButton Devices

APPLICATIONS

- Software Authorization—Protection against software piracy by tying software operation to the presence of iButton hardware.
- iButton Initialization and Download—Loggers like the ThermoChron® can be missioned and downloaded.
- Demonstration—Demonstrate the features of iButtons or 1-Wire chips on personal computers.
- Development—Aid development of 1-Wire applications by providing a PC interface to verify device contents and state.

DESCRIPTION

The DS9490B is a USB bridge and holder for a single F5-size iButton. The iButton is securely held behind a latched door. The DS9490R is a USB bridge with 1-Wire RJ11 interface to accommodate 1-Wire receptacles and networks. For a list of suitable 1-Wire network cables, refer to the *Connectivity Matrix* table in the DS1402x 1-Wire network cables data sheet. Both adapters are based on the DS2490 USB-to-1-Wire bridge chip. Free software drivers for Windows®-based PCs can be downloaded from www.maxim-ic.com/1-Wiredrivers.

1-Wire, iButton, and ThermoChron are registered trademarks of Maxim Integrated Products, Inc.
Windows is a registered trademark of Microsoft Corp.

TYPICAL OPERATING CIRCUIT

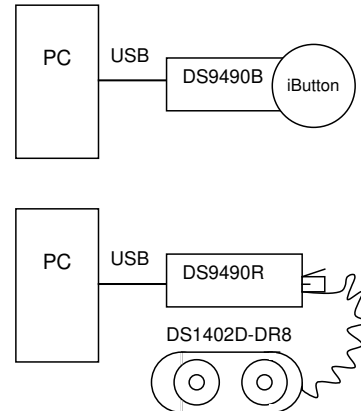

ORDERING INFORMATION

PART	TYPE
DS9490B#	USB Single F5 iButton Holder with Protective Cap
DS9490R#	USB-to-1-Wire RJ11

#Denotes a RoHS-compliant device that may include lead(Pb) that is exempt under the RoHS requirements.

PACKAGING/SHIPPING INFORMATION

The part is shipped individually in an antistatic bag.

Figure 1. DS9490R



Figure 2. DS9490B



***Note:** To eject an iButton, insert a straightened paper clip into the side access hole of the DS9490B. Push the paper clip in the direction of the iButton. A different iButton can then be inserted. The data contact faces down and away from the embossed ‘i’. Before inserting the paper clip disconnect the DS9490B from the USB bus.

Each USB bridge contains a unique built-in identification chip. The identification chip is a custom DS2401 that is a 64-bit ID number (see Figure 3).

Figure 3. DS2401 ID CHIP 64-BIT LASERED ROM

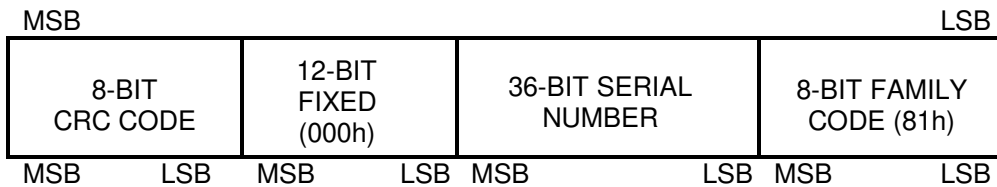

DS9490R/DS9490B

PIN CONFIGURATION

Figure 4. 1-Wire RJ11 SOCKET FOR DS9490R

PIN	SIGNAL NAME	DESCRIPTION
1	V _{DD}	5VDC Output
2	GND	Power Ground
3	OW	1-Wire Data
4	GND_OW	1-Wire Return
5	SUS _O	USB Suspend Output
6	N.C.	No Connection

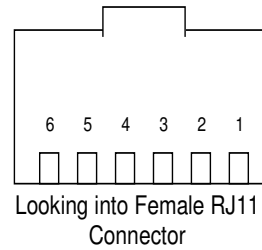
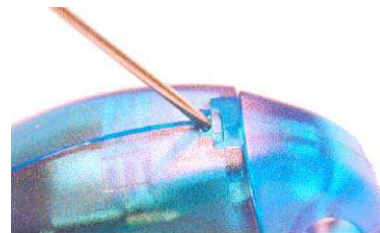
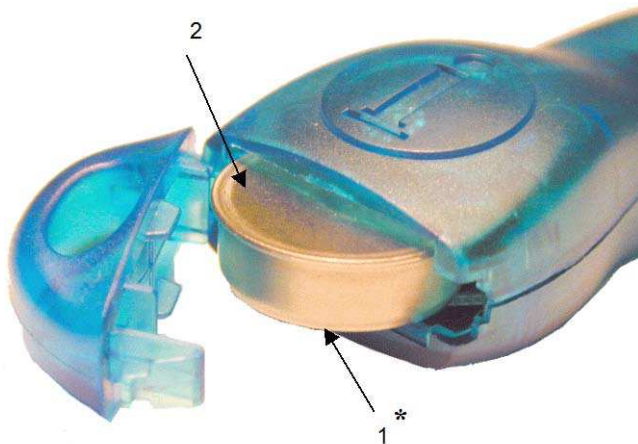

Figure 5. iButton SOCKET FOR DS9490B

PIN	SIGNAL NAME	DESCRIPTION
1	OW	1-Wire Data
2	GND_OW	1-Wire Return



***Note:** The data contact faces down and away from the embossed ‘i’. Once the iButton is inserted in the enclosure, snap the end cap over it. The end cap is removed by depressing the release tab with a paper clip, swinging it fully open, and sliding out the hinge.

MECHANICAL DIMENSIONS

All dimensions are in millimeters.

Figure 6. DS9490R

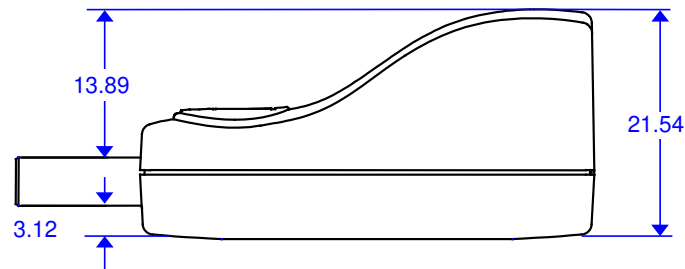
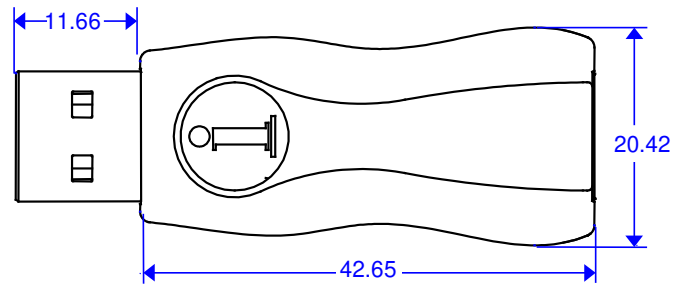
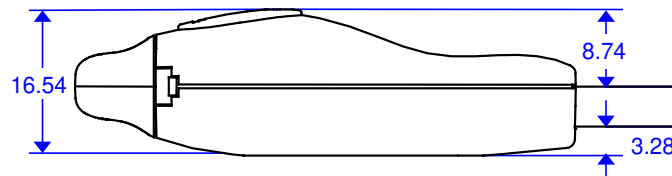
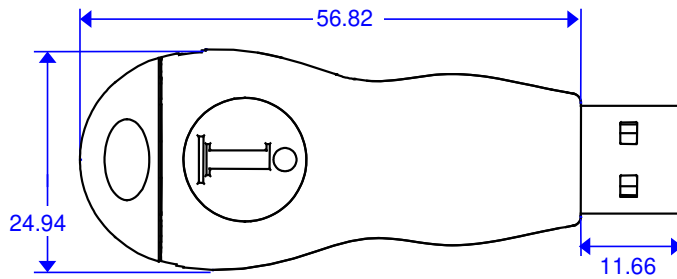

Figure 7. DS9490B



ENVIRONMENTAL REQUIREMENTS

CONDITION	PARAMETER	VALUE
Storage	Temperature	-10°C to +85°C
Storage	Relative humidity, noncondensing	95%
Storage	Duration	1yr (max) at 95%RH and +85°C
Operating	Temperature	0°C to +70°C
Operating	Relative humidity, noncondensing	80%

DS9490R/DS9490B

ELECTRICAL CHARACTERISTICS

PARAMETER	SPECIFICATION
USB I/F	As defined in Chapter 7 of the USB Specification*
1-Wire I/F	See the DS2490 data sheet**

The DS9490R and DS9490B consume 58mA in USB active mode and 0.5mA in suspend mode*. The DS9490R has the V_{BUS} power and ground available on the RJ11 connector. In active mode the current available to an externally powered fixture is 42mA* (100mA to 58mA); however it is recommended that no more than 25mA be used. An external circuit can detect when the module is in suspend by monitoring the \overline{SUSO} signal on Pin 5 of the RJ11 connector. When this condition is detected, the external circuit must also go into a low power state. **NOTE:** The \overline{SUSO} pin of the DS2490 is an open drain output and requires a pullup resistor to create a valid signal. See the DS2490 data sheet for the conditions where \overline{SUSO} is active. Revision C of the DS9490R and all revisions of the DS9490R# have \overline{SUSO} routed to the RJ11 connector. The availability of \overline{SUSO} at the RJ11 connector is not production tested. Therefore, before relying on \overline{SUSO} in an application, first verify the presence of this signal with the particular adapter.

*Guaranteed by design, not production tested.

**Tested at DS2490 component level.

Figure 8. FUNCTIONAL DIAGRAM

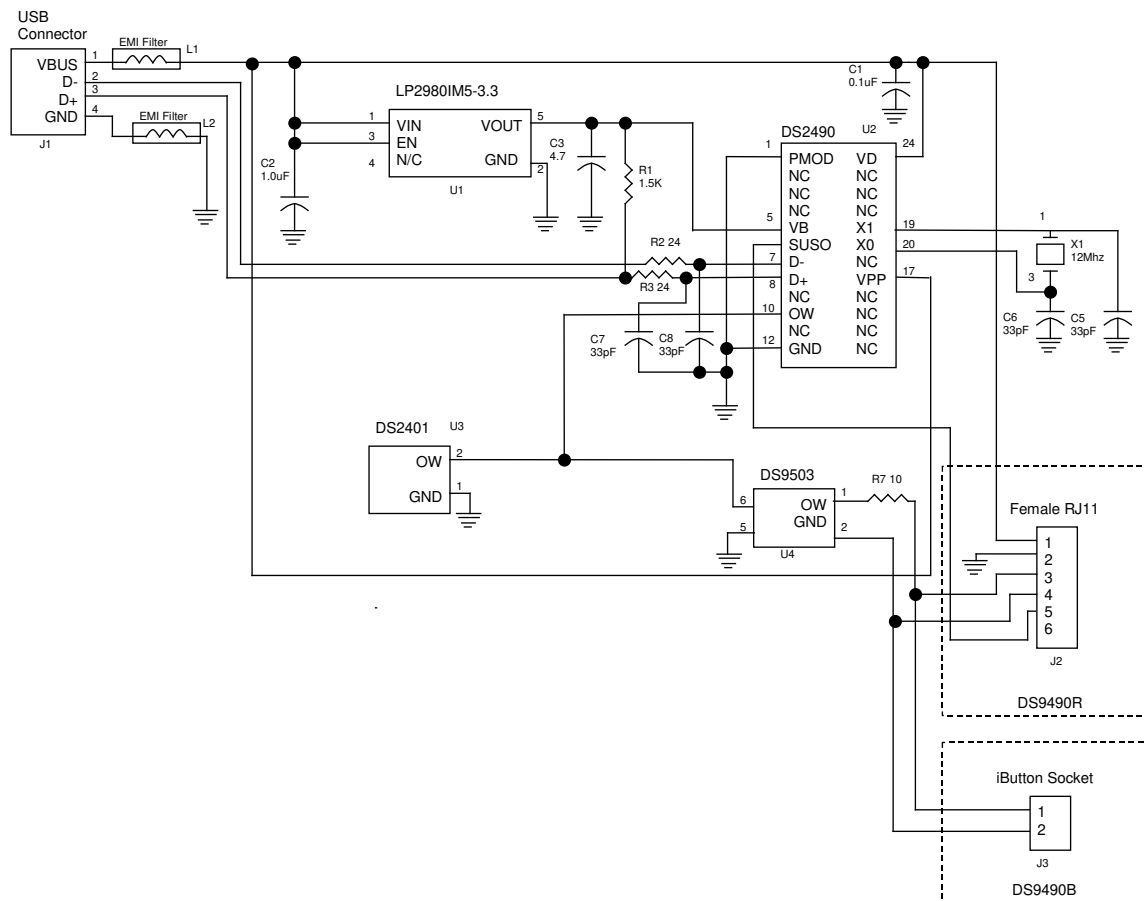

REVISION HISTORY

REVISION DATE	DESCRIPTION	PAGES CHANGED
5/03	Initial release	—
1/07	Added RoHS-compliant part numbers to the <i>Ordering Information</i> table; replaced product graphics with product photos; changed schematic and Figure 4 to route the $\overline{\text{SUSO}}$ signal to RJ11 pin 5; reworded the text in the <i>Electrical Characteristics</i> section to include the $\overline{\text{SUSO}}$ pin and its use	1, 2, 3, 5
8/09	Removed references to leaded packages in the <i>Ordering Information</i> table; added the <i>Revision History</i> table	1, 6
6/11	Deleted reference to monetary iButtons; added reference to the <i>Connectivity Matrix</i> table in the DS1402x 1-Wire network cables data sheet; revised description and URL for software drivers download	1



Maxim cannot assume responsibility for use of any circuitry other than circuitry entirely embodied in a Maxim product. No circuit patent licenses are implied. Maxim reserves the right to change the circuitry and specifications without notice at any time. The parametric values (min and max limits) shown in the Electrical Characteristics table are guaranteed. Other parametric values quoted in this data sheet are provided for guidance.

Maxim Integrated 160 Rio Robles, San Jose, CA 95134 USA 1-408-601-1000

6