



Chipsmall Limited consists of a professional team with an average of over 10 year of expertise in the distribution of electronic components. Based in Hongkong, we have already established firm and mutual-benefit business relationships with customers from,Europe,America and south Asia,supplying obsolete and hard-to-find components to meet their specific needs.

With the principle of “Quality Parts,Customers Priority,Honest Operation,and Considerate Service”,our business mainly focus on the distribution of electronic components. Line cards we deal with include Microchip,ALPS,ROHM,Xilinx,Pulse,ON,Everlight and Freescale. Main products comprise IC,Modules,Potentiometer,IC Socket,Relay,Connector.Our parts cover such applications as commercial,industrial, and automotives areas.

We are looking forward to setting up business relationship with you and hope to provide you with the best service and solution. Let us make a better world for our industry!



Contact us

Tel: +86-755-8981 8866 Fax: +86-755-8427 6832

Email & Skype: info@chipsmall.com Web: www.chipsmall.com

Address: A1208, Overseas Decoration Building, #122 Zhenhua RD., Futian, Shenzhen, China



Low capacitance TVS for high speed lines such as xDSL

Datasheet - production data

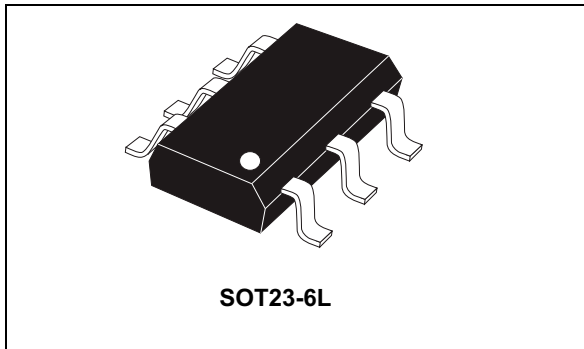

Description

DSL04 is designed to protect VDSL2 line drivers against surges defined in worldwide telecommunication standards. This device protects line drivers for CPE and DSLAM applications. The low capacitance makes it suitable from ADSL to VDSL2 data rates.

DSL04 is able to survive severe conditions even when used with downgraded or oscillating gas tube.

DSL04 is packaged in a SOT23-6L.

Features

- High surge capability to comply with GR-1089 and ITU-T K20/21
- Voltages from 5 to 24 V
- Low capacitance device: $C_{typ} = 1 \text{ pF}$
- RoHS package
- Low leakage current: $0.2 \text{ }\mu\text{A}$ at $25 \text{ }^\circ\text{C}$

Complies with the following standards

- Telcordia GR-1089
 - 2.5 kV 2/10 μs - 500 A 2/10 μs
 - AC power fault tests
- ITU-T K20/21/44
 - 6 kV 10/700 μs - 150 A 5/310 μs
 - Power induction tests
 - Power contact tests
- IEC 61000-4-2, level 4
 - 15 kV (air discharge)
 - 8 kV (contact discharge)
- IEC 61000-4-5, level 2
 - $\pm 1 \text{ kV}$, $42 \text{ }\Omega$
- MIL STD 883G-Method 3015-7: Class 3
 - 8 kV (human body model)

Figure 1. Functional diagram

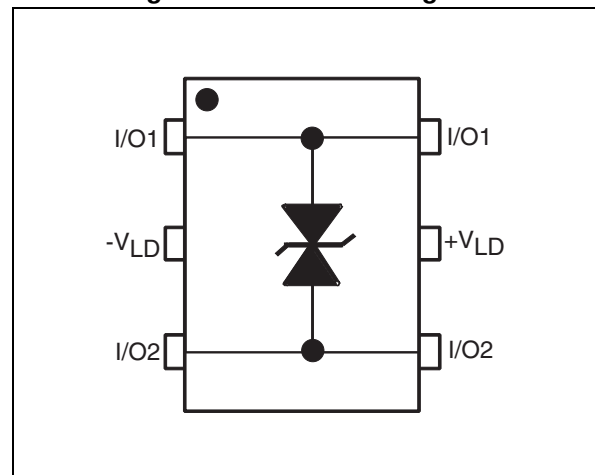

1 Characteristics

Table 1. Absolute ratings ($T_{amb} = 25\text{ °C}$)

| Symbol | Parameter | | Value | Unit |
|-----------|--|---------------------------------|------------|--------------------|
| V_{pp} | Peak pulse voltage | IEC 61000-4-5 contact discharge | 30 | kV |
| I_{pp} | Peak pulse current | 8/20 μ s | 15 | A |
| T_{stg} | Storage temperature range | | -55 to 150 | $^{\circ}\text{C}$ |
| T_j | Operating junction temperature range | | -40 to 125 | $^{\circ}\text{C}$ |
| T_L | Maximum temperature for soldering during 10s | | 260 | $^{\circ}\text{C}$ |

Table 2. Electrical characteristics ($T_{amb} = 25\text{ °C}$)

| Order code | $I_{RM} @ V_{RM}$ | | $V_{BR} @ I_{BR}$ | | $V_{CL} @ I_{PP}$ 8/20 μ s | | C | | ΔC |
|--------------|-------------------|----|-------------------|----|-----------------------------------|----|---------------------------|---------------------------|---------------------------|
| | Max. μ A | V | Min. V | mA | Max. V | A | Typ. ⁽¹⁾ pF | Max. ⁽¹⁾ pF | Typ. ⁽²⁾ pF |
| DSL04-005SC6 | 0.2 | 5 | 6.5 | 1 | 20 | 15 | 1 | 3 | 0.3 |
| DSL04-008SC6 | 0.2 | 8 | 10 | 1 | 25 | 15 | 1 | 3 | 0.3 |
| DSL04-010SC6 | 0.2 | 10 | 11 | 1 | 27 | 15 | 1 | 3 | 0.3 |
| DSL04-012SC6 | 0.2 | 12 | 14 | 1 | 31 | 15 | 1 | 3 | 0.3 |
| DSL04-016SC6 | 0.2 | 16 | 20 | 1 | 37 | 15 | 1 | 3 | 0.3 |
| DSL04-018SC6 | 0.2 | 18 | 21 | 1 | 39 | 15 | 1 | 3 | 0.3 |
| DSL04-020SC6 | 0.2 | 20 | 23 | 1 | 42 | 15 | 1 | 3 | 0.3 |
| DSL04-022SC6 | 0.2 | 22 | 25 | 1 | 45 | 15 | 1 | 3 | 0.3 |
| DSL04-024SC6 | 0.2 | 24 | 27 | 1 | 52 | 15 | 1 | 3 | 0.3 |

1. Test conditions: $V_R = 2\text{ V}$ bias, $V_{RMS} = 1\text{ V}$, $F = 1\text{ MHz}$

2. Measured between 1 V and V_{RM}

Figure 2. Leakage current versus junction temperature (typical values)

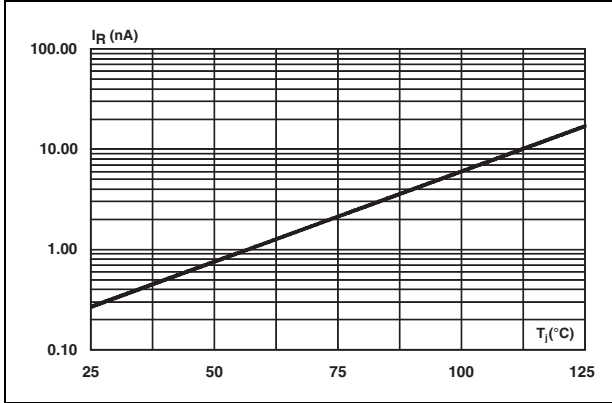

Figure 3. Junction capacitance versus reverse voltage applied (typical values)

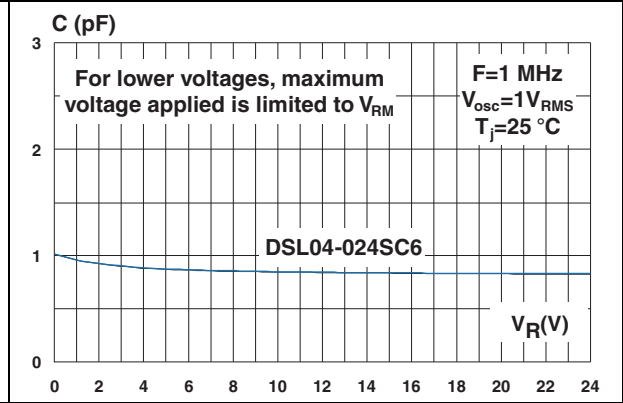
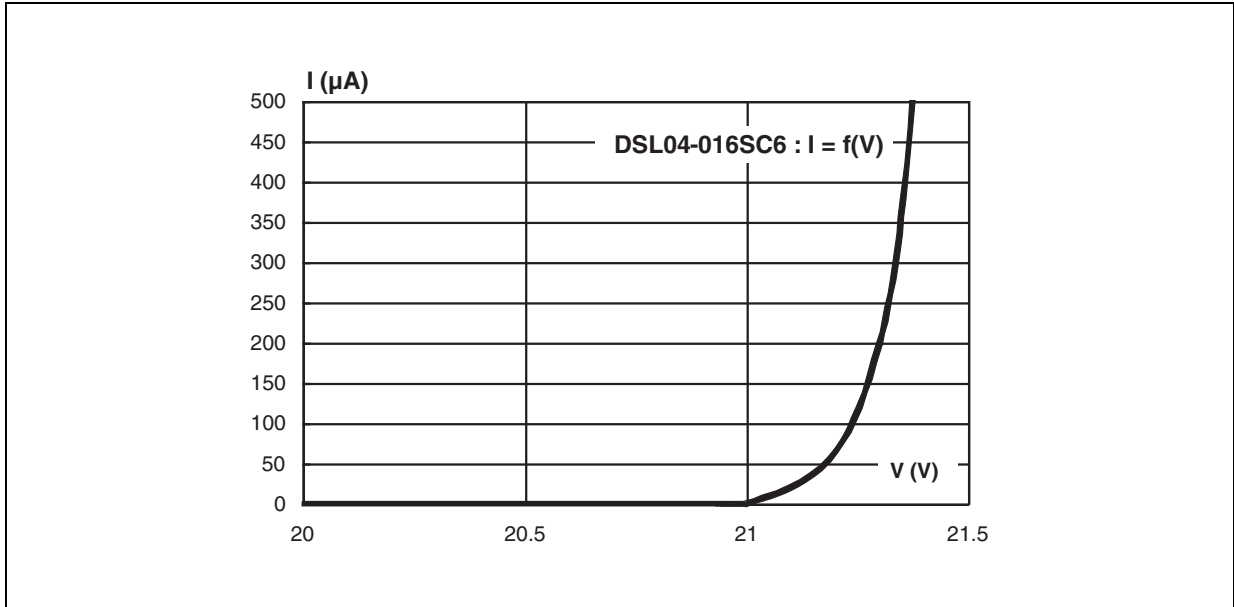

Figure 4. I / V characteristics (typical values)



2 Package information

- Epoxy meets UL94, V0
- Lead-free package

In order to meet environmental requirements, ST offers these devices in different grades of ECOPACK® packages, depending on their level of environmental compliance. ECOPACK® specifications, grade definitions and product status are available at: www.st.com. ECOPACK® is an ST trademark.

Figure 5. SOT23-6L dimension definitions

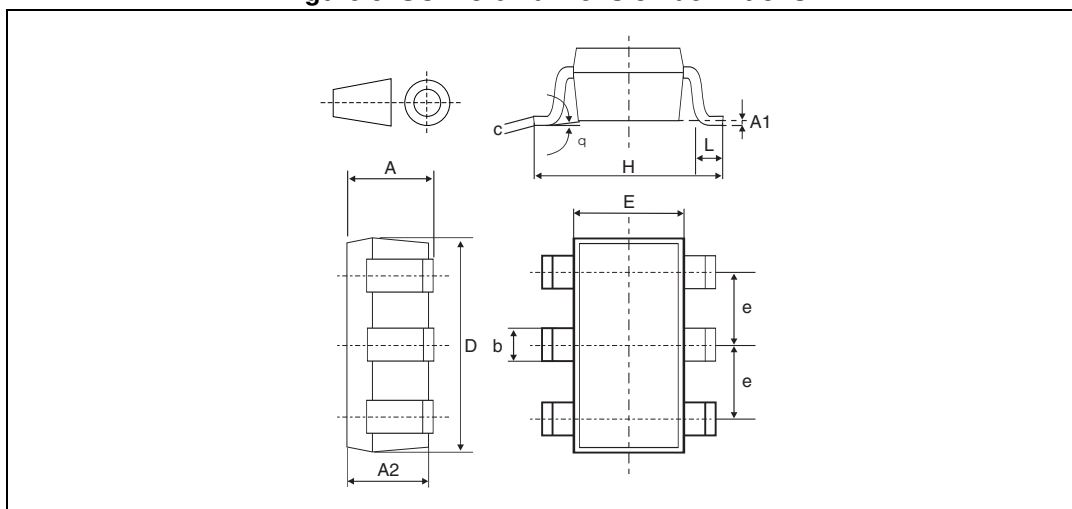

Table 3. SOT23-6L dimension values

| Ref. | Dimensions | | | | | |
|------|-------------|------|------|--------|-------|-------|
| | Millimeters | | | Inches | | |
| | Min. | | Max. | Min. | | Max. |
| A | 0.90 | | 1.45 | 0.035 | | 0.057 |
| A1 | 0 | | 0.10 | 0 | | 0.004 |
| A2 | 0.90 | | 1.30 | 0.035 | | 0.051 |
| b | 0.35 | | 0.50 | 0.014 | | 0.020 |
| c | 0.09 | | 0.20 | 0.004 | | 0.008 |
| D | 2.80 | | 3.05 | 0.11 | | 0.118 |
| E | 1.50 | | 1.75 | 0.059 | | 0.069 |
| e | | 0.95 | | | 0.037 | |
| H | 2.60 | | 3.00 | 0.102 | | 0.118 |
| L | 0.10 | | 0.60 | 0.004 | | 0.024 |
| θ | 0° | | 10° | 0° | | 10° |

Figure 6. Footprint recommendations dimensions in mm (inches)

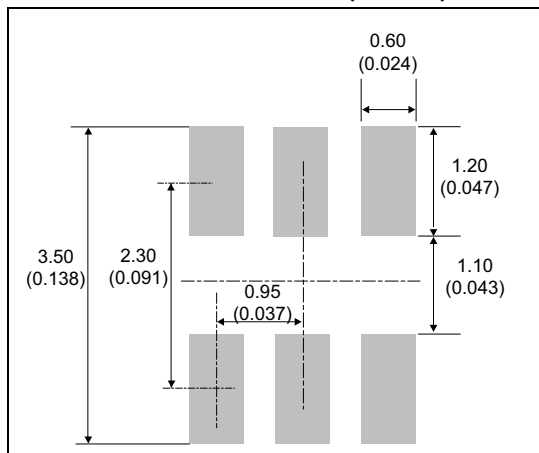
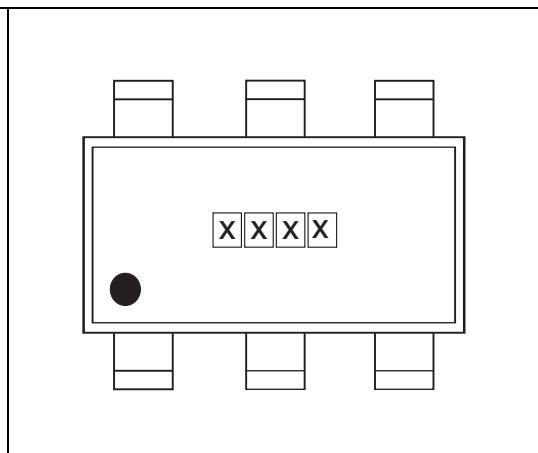

Figure 7. Marking layout



3 Ordering information

Figure 8. Ordering information scheme

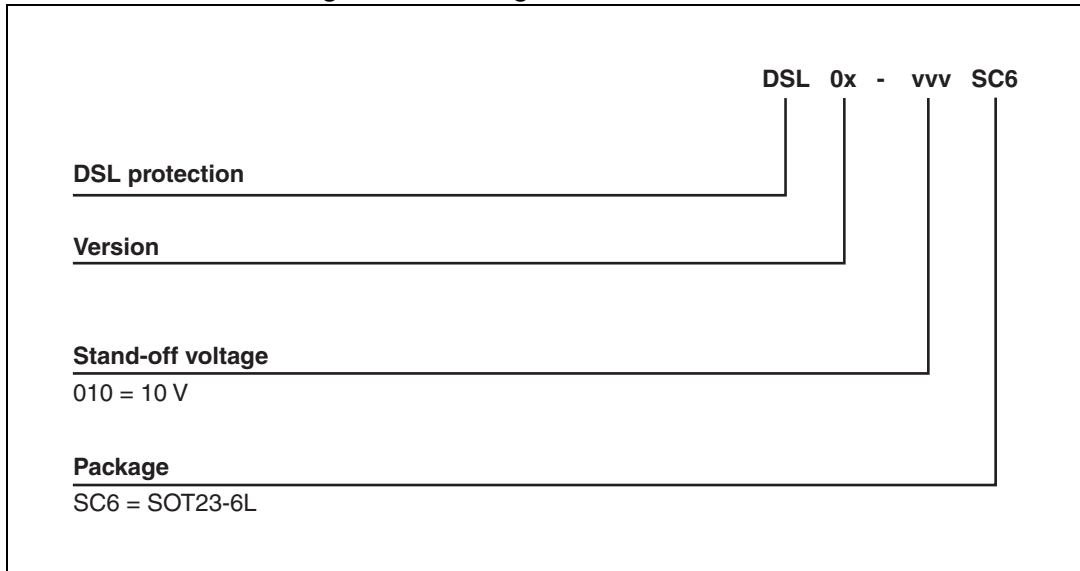

Table 4. Ordering information

| Ordering code | Marking | Package | Weight | Base qty | Delivery mode |
|---------------|---------|----------|--------|----------|---------------|
| DSL04-005SC6 | DT05 | SOT23-6L | 14 mg | 3000 | Tape and reel |
| DSL04-008SC6 | DT08 | | | | |
| DSL04-010SC6 | DT10 | | | | |
| DSL04-012SC6 | DT12 | | | | |
| DSL04-016SC6 | DT16 | | | | |
| DSL04-018SC6 | DT18 | | | | |
| DSL04-020SC6 | DT20 | | | | |
| DSL04-022SC6 | DT22 | | | | |
| DSL04-024SC6 | DT24 | | | | |

4 Revision history

Table 5. Document revision history

| Date | Revision | Changes |
|-------------|----------|----------------------------------|
| 24-Feb-2012 | 1 | Initial release |
| 03-Feb-2015 | 2 | Reformatted to current standard. |

IMPORTANT NOTICE – PLEASE READ CAREFULLY

STMicroelectronics NV and its subsidiaries (“ST”) reserve the right to make changes, corrections, enhancements, modifications, and improvements to ST products and/or to this document at any time without notice. Purchasers should obtain the latest relevant information on ST products before placing orders. ST products are sold pursuant to ST’s terms and conditions of sale in place at the time of order acknowledgement.

Purchasers are solely responsible for the choice, selection, and use of ST products and ST assumes no liability for application assistance or the design of Purchasers’ products.

No license, express or implied, to any intellectual property right is granted by ST herein.

Resale of ST products with provisions different from the information set forth herein shall void any warranty granted by ST for such product.

ST and the ST logo are trademarks of ST. All other product or service names are the property of their respective owners.

Information in this document supersedes and replaces information previously supplied in any prior versions of this document.

© 2015 STMicroelectronics – All rights reserved