



Chipsmall Limited consists of a professional team with an average of over 10 year of expertise in the distribution of electronic components. Based in Hongkong, we have already established firm and mutual-benefit business relationships with customers from,Europe,America and south Asia,supplying obsolete and hard-to-find components to meet their specific needs.

With the principle of “Quality Parts,Customers Priority,Honest Operation,and Considerate Service”,our business mainly focus on the distribution of electronic components. Line cards we deal with include Microchip,ALPS,ROHM,Xilinx,Pulse,ON,Everlight and Freescale. Main products comprise IC,Modules,Potentiometer,IC Socket,Relay,Connector.Our parts cover such applications as commercial,industrial, and automotives areas.

We are looking forward to setting up business relationship with you and hope to provide you with the best service and solution. Let us make a better world for our industry!



Contact us

Tel: +86-755-8981 8866 Fax: +86-755-8427 6832

Email & Skype: info@chipsmall.com Web: www.chipsmall.com

Address: A1208, Overseas Decoration Building, #122 Zhenhua RD., Futian, Shenzhen, China



Trapped Double Key Interlocks

Slamlock double key interlock is similar to the single key version but has a secondary key to allow '2 key in' or 'key exchange' conditions. The key exchange version may be used where whole body access is required, as the secondary key can be used as a personnel key.

- 450 lb. locking force
- Variety of actuator types available
- Direct drive push/pull operation
- 316 stainless steel construction
- Virtually maintenance free
- Weatherproof stainless steel dust cap as standard
- Fitted with tamper resistant screws
- Screws may be applied from the rear for increased tamper resistance



Specifications

Operating Temperature:	-20 to 80°C (-4 to 176°F)
Mechanical Operations:	>10 ⁵ under normal working conditions
Max. Shear Force to Key:	15.1 kN
Max. Torque to Key:	14 Nm
Max. Holding Force:	2000 N (450 lb.)
Relative Operating Humidity:	25% to 95%
Weight:	1332 gm (47 oz.)
Material:	316L stainless steel
Mounting:	2 x M5
Code Barrels:	Tested to 100,000 operations
Conforms to Standards:	Relevant clauses EN292, EN1088 & GS ET 19
Approvals:	CE marked for all applicable directives and BG

Specifications are subject to change without notice.

M

Applications

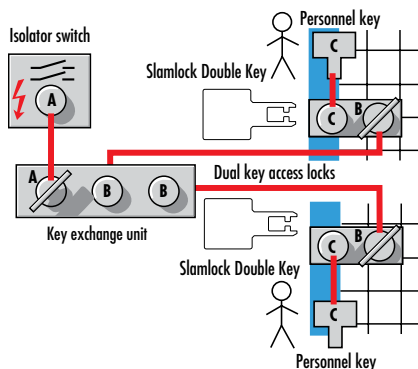

Dimensions

(mm/in.)

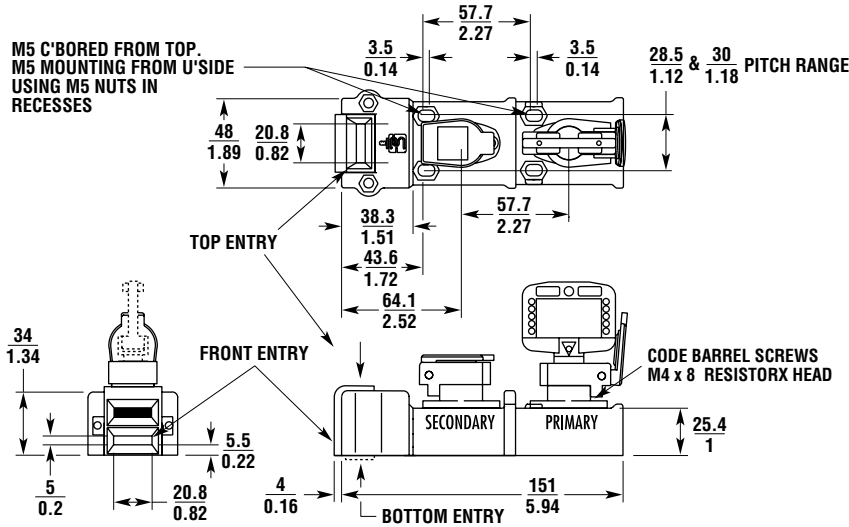

Standard Actuator

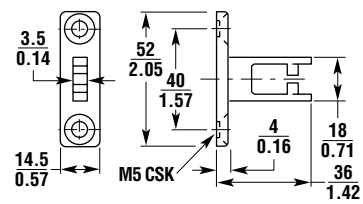

Flexible 1 Actuator

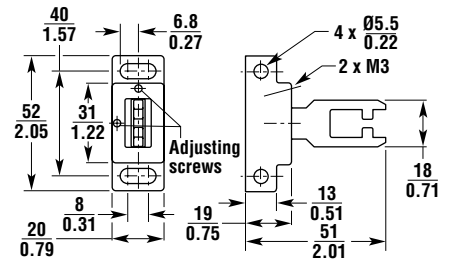

Flat Actuator

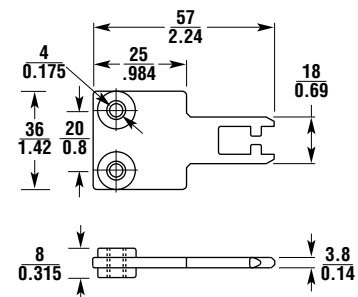

Ordering

Slamlock Double Key Interlock

Primary key is trapped, secondary key is free to release actuator.

Part No.	Actuator
DSLE10	Standard
DSLE11	Flexible
DSLE12	Flat
DSLE13	Flat with 305 mm chain

Both keys trapped to release actuator. **Keys not included.**

Part No.	Actuator
DSLE14	Standard
DSLE15	Flexible
DSLE16	Flat
DSLE17	Flat with 305 mm chain
44519-0700	Spare standard actuator
44519-0710	Spare flexible actuator
44519-0720	Spare flat actuator

Codes 'A' to 'Z' available excluding the letter 'Q'. To specify coding, add the key code of your choice from the Key Code Table to the part no. from the Ordering Table, i.e. DSLE10(A) [B] is a Double Slamlock unit with the secondary key supplied trapped.

Primary key is ordered separately.

For coding details and referencing, see page M5.

To order keys, see Accessories on page M30.

Key Codes

(...) = Primary key / key free

[...] = Secondary key / key trapped

Codes						
A	Aa	Ab	Ac	Ad	Ae	Af
B	Ba	Bb	Bc	Bd	Be	Bf
C	Ca	Cb	Cc	Cd	Ce	Cf
D	Da	Db	Dc	Dd	De	Df
E	Ea	Eb	Ec	Ed	Ee	Ef
F	Fa	Fb	Fc	Fd	Fe	Ff
G	Ga	Gb	Gc	Gd	Ge	Gf
H	Ha	Hb	Hc	Hd	He	Hf
I	Ia	Ib	Ic	Id	Ie	If
J	Ja	Jb	Jc	Jd	Je	Jf
K	Ka	Kb	Kc	Kd	Ke	Kf
L	La	Lb	Lc	Ld	Le	Lf
M	Ma	Mb	Mc	Md	Me	Mf
N	Na	Nb	Nc	Nd	Ne	Nf
O	Oa	Ob	Oc	Od	Oe	Of
P	Pa	Pb	Pc	Pd	Pe	Pf
R	Ra	Rb	Rc	Rd	Re	Rf
S	Sa	Sb	Sc	Sd	Se	Sf
T	Ta	Tb	Tc	Td	Te	Tf
U	Ua	Ub	Uc	Ud	Ue	Uf
V	Va	Vb	Vc	Vd	Ve	Vf
W	Wa	Wb	Wc	Wd	We	Wf
X	Xa	Xb	Xc	Xd	Xe	Xf
Y	Ya	Yb	Yc	Yd	Ye	Yf
Z	Za	Zb	Zc	Zd	Ze	Zf

OMRON AUTOMATION AND SAFETY • THE AMERICAS HEADQUARTERS • Chicago, IL USA • 847.843.7900 • 800.556.6766 • www.omron247.com

OMRON CANADA, INC. • HEAD OFFICE

Toronto, ON, Canada • 416.286.6465 • 866.986.6766 • www.omron247.com

OMRON ELECTRONICS DE MEXICO • HEAD OFFICE

México DF • 52.55.59.01.43.00 • 01-800-226-6766 • mela@omron.com

OMRON ELECTRONICS DE MEXICO • SALES OFFICE

Apodaca, N.L. • 52.81.11.56.99.20 • 01-800-226-6766 • mela@omron.com

OMRON ELETRÔNICA DO BRASIL LTDA • HEAD OFFICE

São Paulo, SP, Brasil • 55.11.2101.6300 • www.omron.com.br

OMRON ARGENTINA • SALES OFFICE

Cono Sur • 54.11.4783.5300

OMRON CHILE • SALES OFFICE

Santiago • 56.9.9917.3920

OTHER OMRON LATIN AMERICA SALES

54.11.4783.5300

OMRON EUROPE B.V. • Wegalaan 67-69, NL-2132 JD, Hoofddorp, The Netherlands. • +31 (0) 23 568 13 00 • www.industrial.omron.eu

Authorized Distributor:

Automation Control Systems

- Machine Automation Controllers (MAC) • Programmable Controllers (PLC)
- Operator interfaces (HMI) • Distributed I/O • Software

Drives & Motion Controls

- Servo & AC Drives • Motion Controllers & Encoders

Temperature & Process Controllers

- Single and Multi-loop Controllers

Sensors & Vision

- Proximity Sensors • Photoelectric Sensors • Fiber-Optic Sensors
- Amplified Photomicrosensors • Measurement Sensors
- Ultrasonic Sensors • Vision Sensors

Industrial Components

- RFID/Code Readers • Relays • Pushbuttons & Indicators
- Limit and Basic Switches • Timers • Counters • Metering Devices
- Power Supplies

Safety

- Laser Scanners • Safety Mats • Edges and Bumpers • Programmable Safety Controllers • Light Curtains • Safety Relays • Safety Interlock Switches