



Chipsmall Limited consists of a professional team with an average of over 10 year of expertise in the distribution of electronic components. Based in Hongkong, we have already established firm and mutual-benefit business relationships with customers from,Europe,America and south Asia,supplying obsolete and hard-to-find components to meet their specific needs.

With the principle of “Quality Parts,Customers Priority,Honest Operation,and Considerate Service”,our business mainly focus on the distribution of electronic components. Line cards we deal with include Microchip,ALPS,ROHM,Xilinx,Pulse,ON,Everlight and Freescale. Main products comprise IC,Modules,Potentiometer,IC Socket,Relay,Connector.Our parts cover such applications as commercial,industrial, and automotives areas.

We are looking forward to setting up business relationship with you and hope to provide you with the best service and solution. Let us make a better world for our industry!



Contact us

Tel: +86-755-8981 8866 Fax: +86-755-8427 6832

Email & Skype: info@chipsmall.com Web: www.chipsmall.com

Address: A1208, Overseas Decoration Building, #122 Zhenhua RD., Futian, Shenzhen, China



56F800 Demonstration Board

User Manual

56F800
16-bit Digital Signal Controllers

DSP56F800DBUM
Rev. 0
09/2005

freescale.com

TABLE OF CONTENTS

Preface

Chapter 1 Introduction

| | | |
|-----|---|-----|
| 1.1 | 56F800 Demonstration Board Features | 1-1 |
| 1.2 | SPECIFICATIONS | 1-3 |

Chapter 2 Technical Summary

| | | |
|-------|---------------------------------|-----|
| 2.1 | OPTIONS | 2-1 |
| 2.1.1 | HOST_ENABLE | 2-1 |
| 2.1.2 | CUT_AWAY Options | 2-1 |
| 2.2 | PORTS AND CONNECTORS | 2-2 |
| 2.2.1 | PWR Jack | 2-2 |
| 2.2.2 | POWER PORT | 2-2 |
| 2.2.3 | GPIO / SERIAL | 2-2 |
| 2.2.4 | TIMER / PWM | 2-3 |
| 2.2.5 | ADC Port | 2-3 |
| 2.2.6 | COM1 | 2-3 |
| 2.2.7 | JTAG / OnCE | 2-3 |
| 2.2.8 | P1 - HOST JTAG | 2-4 |
| 2.3 | USER FEATURES | 2-4 |
| 2.3.1 | MICROPHONE | 2-4 |
| 2.3.2 | POTENTIOMETER (POT) - R12 | 2-5 |
| 2.4 | Indicators | 2-5 |

Appendix A 56F800 Demonstration Board Schematics

LIST OF FIGURES

| | | |
|-----|--------------------------------------|-----|
| 1-1 | 56F800 Demonstration Board | 1-2 |
| 2-1 | Power Port | 2-2 |
| A-1 | 56F800 Demonstration Board | A-2 |

TABLE OF CONTENTS

| | | |
|-----|------------------------|-----|
| 2-1 | CUT_AWAY Options | 2-1 |
| 2-2 | Indicators | 2-5 |

Preface

This reference manual describes in detail the hardware on the 56F800 Demonstration Board.

Audience

This document is intended for application developers who are creating software for devices using the Freescale 56F800 Demonstration Board.

Organization

This manual is organized into two chapters and one appendix.

- **Chapter 1, Introduction** - provides an overview of the Demonstration Board and its features.
- **Chapter 2, Technical Summary** - describes the 56F800 Demonstration Board in detail.
- **Appendix A, 56F800 Demonstration Board Schematics** - contains the schematics of the 56F800 Demonstration Board.

Suggested Reading

Related documentation for the 56F800 family of digital signal controllers may be found at:

<http://www.freescale.com/dsc>

Notation Conventions

This manual uses the following notational conventions:

| Typeface, Symbol or Term | Meaning | Examples | Typeface, Symbol or Term |
|----------------------------|--|---|----------------------------|
| Courier Monospaced Type | Code examples | //Process command for line flash | Courier Monospaced Type |
| <i>Italic</i> | Directory names, project names, calls, functions, statements, procedures, routines, arguments, file names, applications, variables, directives, code snippets APIs in text | ...and contains these core directories: <i>applications</i> contains applications software... ...CodeWarrior project, <i>3des.mcp</i> is... ...the <i>pConfig</i> argument... ...defined in the C header file, <i>aec.h</i> ... | <i>Italic</i> |
| Bold | Reference sources, paths, emphasis | ...refer to the Target- ing DSP56F80x Plat- form manual... ...see: C:\Program Files\Embedded SDK\help\tutorials | Bold |
| Blue Text | Linkable | ...refer to Chapter 7 , License.... | Blue Text |
| Number | Any number is consid- ered a positive value, unless preceded by a minus symbol to sig- nify a negative value | 3V -10 DES ⁻¹ | Number |
| ALL CAPITAL LET- TERS | # defines/ defined constants | # define INCLUDE_STACK_CH ECK | ALL CAPITAL LETTERS |
| Brackets [...] | Function keys | ...by pressing function key [F7] | Brackets [...] |

Cautionary Notes

1. Electrostatic Discharge (ESD) prevention measures should be applied whenever handling this product. ESD damage is not a warranty repair item.
2. EMC Information on the 56F800 Demonstration Board:
 - a. This product as shipped from the factory with associated power supplies and cables, has been tested and meets with requirements of CE and the FCC as a CLASS A product.
 - b. This product is designed and intended for use as a development platform for hardware or software in an educational or professional laboratory.
 - c. In a domestic environment this product may cause radio interference in which case the user may be required to take adequate prevention measures.
 - d. Attaching additional wiring to this product or modifying the products operation from the factory default as shipped may effect its performance and also cause interference with other apparatus in the immediate vicinity. If such interference is detected, suitable mitigating measures should be taken.

Terminology

This development board applies option selection jumpers. Terminology for application of the option jumpers is as follows:

Jumper on, in, or installed = jumper is a plastic shunt that fits across 2 pins and the shunt is installed so that the 2 pins are connected with the shunt.

Jumper off, out, or idle = jumper or shunt is installed so that only 1 pin holds the shunt, no 2 pins are connected, or jumper is removed. It is recommended that the jumpers be idled by installing on 1 pin so they will not be lost.

This development board applies CUT_AWAY option selections. These option selections apply surface mount resistor locations with a printed circuit board trace connecting both component pads. This type connection places an equivalent 0-ohm type resistor in series with the I/O signal and the user component or I/O connector on the board. These connections maybe cut with a razor blade or similar type knife between the component pads to isolate the default connection provided. Reconnection of the cut-away type pads can be made by either installing a 0 ohm 0805 size surface mount resistor or a small wire jumper on the component pads.

Definitions, Acronyms, and Abbreviations

Definitions, acronyms and abbreviations for terms used in this document are defined below for reference.

| | |
|--------------|--|
| ADC | Analog-to-Digital Converter |
| CTS | Clear To Send |
| ESD | Electrostatic Discharge |
| GPIO | General Purpose Input and Output Port |
| JTAG | Joint Test Action Group. A bus protocol/interface used for test and debug. |
| OnCE™ | On-Chip Emulation, a debug bus and port created by Freescale to enable designers to create a low-cost hardware interface for a professional quality debug environment. |
| PC | Personal Computer |
| POT | Potentiometer |
| PWM | Pulse Width Modulation |
| RTS | Request To Send |

References

The following sources were referenced to produce this manual:

DSP56800 Family Manual

DSP56F80x User's Manual

Technical Data, 56F801 16-Bit Digital Signal Controller

Chapter 1

Introduction

The 56F800 Demonstration Board is used to demonstrate the abilities of the 56F800 family and to provide a hardware tool allowing the development of applications that use the 56F800 devices.

1.1 56F800 Demonstration Board Features

- 56F801FA60 (60 MHz version)
- RESET Switch
- IRQ Switch
- GPIO / SERIAL Port (10 pin) *
- TIMER / PWM Port (10 Pin) *
- ADC Port (10 Pin) *
- JTAG / OnCE Port (14 pin) *
- Host JTAG Port (P1- DB25P)
- COM1 Port - SCI to RS232 (DB9S) *
- PWR Jack supply connector
- Power Port *
- Power Indicator
- 10 User Indicators
- User Potentiometer (R12)
- Microphone with amplifier
- Crystal Reference (Y1) *

* All components may not be installed at the factory. The user may install the components to apply associated feature.

The 56F800 Demonstration Board is detailed in [Figure 1-1](#).

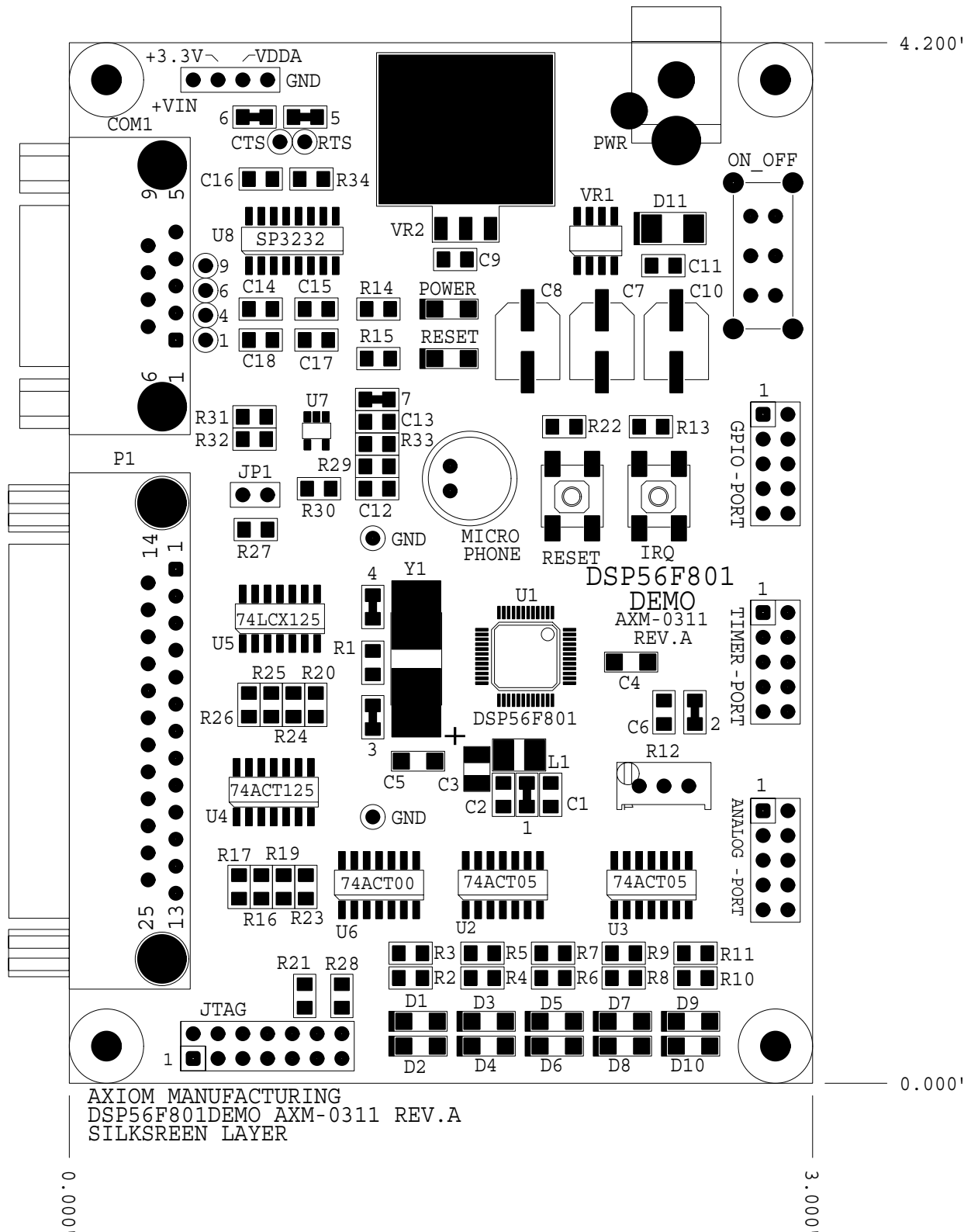

Figure 1-1. 56F800 Demonstration Board

1.2 SPECIFICATIONS

- +9V DC input voltage typical, 200ma
- Input voltage range: +7 to +15V DC
- On board regulated +5V DC and +3.3V DC supplies
- Board size: 3 x 4.2 inches

Chapter 2

Technical Summary

This chapter describes the 56F800 Demonstration Board's available options.

2.1 OPTIONS

2.1.1 HOST_ENABLE

The HOST_ENABLE option jumper is installed by default and enables the Host JTAG interface on the board. With the option jumper installed, the 56F801 device will reset into Debug mode and await Host commands on the Host JTAG port (P1). Removing the HOST_ENABLE option jumper will allow the 56F801 device to reset normally and execute program code contained in the device's Flash memory.

- **HOST_ENABLE = INSTALLED:** Debug Mode; host JTAG port is active
- **HOST_ENABLE = OPEN or IDLE:** Normal Mode; executes user code in Flash

2.1.2 CUT_AWAY Options

CUT_AWAY options allow the user to disconnect dedicated 56F801 I/O port resources from development board connectors or peripherals. The CUT_AWAY options also allow for re-establishing the connection by installing surface-mount 0805-size 0 ohm resistors or mod wire with the use of a soldering iron. Normal operation of the 56F800 Demonstration Board generally does not require any manipulation of the CUT_AWAY options.

Table 2-1. CUT_AWAY Options

| CUT_AWAY # | Description | 56F801 Signal | Connection Signal |
|------------|------------------------------|------------------|---------------------|
| 1 | ADC reference supply | V _{REF} | V _{DDA} |
| 2 | User POT (R12) to ADC | ANA6 | R12 wiper |
| 3 | Crystal oscillator isolation | XTAL / GPIOB3 | GPIO / SERIAL pin 4 |

Table 2-1. CUT_AWAY Options (Continued)

| CUT_AWAY # | Description | 56F801 Signal | Connection Signal |
|------------|------------------------------|----------------|------------------------------|
| 4 | Crystal oscillator isolation | EXTAL / GPIOB2 | GPIO / SERIAL pin 3 |
| 5 | COM1 serial port | TXD0 / GPIO0 | U8 pin 11 (COM1 TXD) |
| 6 | COM1 serial port | RXD0 / GPIOB1 | U8 pin 12 (COM1 RXD) |
| 7 | Microphone to ADC | ANA2 | U7 pin 4 (Microphone output) |

2.2 PORTS AND CONNECTORS

2.2.1 PWR Jack

This connector provides power input to the board by default. The PWR jack accepts a standard 2.0 ~ 2.1mm center-barrel plug connector (positive voltage center) to provide the +VIN supply of +9V DC at 200ma.

2.2.2 POWER PORT

Provides access to the +9V DC input, GND (power ground), +5V DC and +3.3V DC power supplies. The +9V DC input should only be applied by PWR jack or Power Port, but not both, or a supply conflict may occur and the 56F800 Demonstration Board could be damaged. Power Port accepts a 3.5mm pin space terminal block.

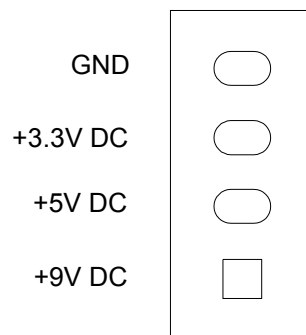

Figure 2-1. Power Port

2.2.3 GPIO / SERIAL

| | | | |
|---------------|---|----|---------------|
| TXD0 / GPIOB0 | 1 | 2 | GPIOB1 / RXD0 |
| GPIOB2 | 3 | 4 | GPIOB3 |
| SCLK / GPIOB4 | 5 | 6 | GPIOB5 / MOSI |
| MISO / GPIOB6 | 7 | 7 | GPIOB7 / SS* |
| IREQA* | 9 | 10 | RESET* |

GPIO B port provides alternate functions as SCI (COM1 and indications) and SPI ports. IREQ and RESET signals are also provided on this connector.

2.2.4 TIMER / PWM

| | | | |
|--------------|---|----|--------------|
| TD0 / GPIOA0 | 1 | 2 | GPIOA1 / TD1 |
| TD2 / GPIOA2 | 3 | 4 | FAULTA0 |
| PWMA4 | 5 | 6 | PWMA5 |
| PWMA2 | 7 | 7 | PWMA3 |
| PWMA0 | 9 | 10 | PWMA1 |

GPIOA0 - 2 port provides alternate functions of Timer TD0 - 2 I/O. Note that most of these ports provide a user indication.

2.2.5 ADC Port

| | | | |
|------|---|----|------|
| ANA6 | 1 | 2 | ANA7 |
| ANA4 | 3 | 4 | ANA5 |
| ANA2 | 5 | 6 | ANA3 |
| ANA0 | 7 | 7 | ANA1 |
| VREF | 9 | 10 | GND |

Analog inputs. Note that ANA2 and ANA6 provide Microphone and User POT R12 input, respectively.

2.2.6 COM1

| | | | |
|------|---|---|-----|
| 1 | 1 | | |
| TXD0 | 2 | 6 | 6 |
| RXD0 | 3 | 7 | CTS |
| 4 | 4 | 8 | RTS |
| GND | 5 | 9 | 9 |

The **COM1** port has a female DB9 connector that interfaces to the 56F801 internal SCI0 serial port via the U8 RS-232 transceiver. It uses a simple 2-wire asynchronous serial interface and is translated to RS-232 signaling levels.

1,4,6 connected (host null)

RTS and CTS flow control connection pads are provided on the 56F800 Demonstration Board to apply unassigned 56F801 I/O to support flow control on COM1. The RTS pad provides RS-232 level output conversion to COM1 port pin 8. The CTS pad provides RS-232-converted input from COM1 pin 7.

The 1, 4, 6, and 9 pins provide RS-232 status. The 1, 4, and 6 pins are connected on the bottom of the development board to provide NULL status to the host. The user may isolate pins and provide the status connections to the host by applying I/O signals and RS-232 level conversion.

2.2.7 JTAG / OnCE

The JTAG 14-pin connector is compatible with the Freescale OnCE development port. This connector allows the connection of a OnCE-style background debug cable for software development, programming and debugging in real time.

| | | | | |
|----------|----|----|----------|-----------------------------|
| TDI | 1 | 2 | GND | JTAG / OnCE BDM connection. |
| TDO | 3 | 4 | GND | |
| TCK | 5 | 6 | GND | |
| | 7 | 7 | (key) | |
| RESET in | 9 | 10 | TMS | |
| +3.3V DC | 11 | 12 | | |
| DE* | 13 | 14 | TRST* in | |

Note: HOST_ENABLE option must be open or idle to apply this connector.

2.2.8 P1 - HOST JTAG

The P1 - Host JTAG connector provides development port interface to a hosting Personal Computer's LPT or Printer port. The HOST_ENABLE option jumper must be installed for this port to operate.

| | | | | |
|----------------|----|----|-----------|---|
| | 1 | 14 | | P1 - HOST JTAG connector is a DB25 pin connector. Signals are organized for direct connection to an IBM-compatible PC with a straight-through DB25 cable. |
| Reset in | 2 | 15 | Pin 8 tie | |
| TMS | 3 | 16 | GND | |
| TCK | 4 | 17 | | |
| TDI | 5 | 18 | GND | |
| TRST* | 6 | 19 | GND | |
| DE* (Note R23) | 7 | 20 | GND | |
| Pin 15 tie | 8 | 21 | GND | |
| | 9 | 22 | GND | |
| | 10 | 23 | GND | |
| TDO | 11 | 24 | GND | |
| | 12 | 25 | GND | |
| P-CON | 13 | | | |

Pin 7 / DE* signal, if supported, can be enabled by installing R23 (51 ohms)

Note: HOST_ENABLE option must be installed to apply this connector.

2.3 USER FEATURES

Several circuits are provided for demonstration of 56F800 applications.

2.3.1 MICROPHONE

A microphone with audio amplifier is provided on the 56F800 Demonstration Board for user applications. The amplifier provides low-pass filtering starting at ~4000Hz for speech input. The audio signal from the microphone amplifier is provided to the ADC ANA2 input channel via CUT_AWAY option #7.

2.3.2 POTENTIOMETER (POT) - R12

The user POT R12 provides a 0 to +3.3V adjustable analog input to the 56F801's ADC ANA6 channel. R12 can be removed from the ANA6 channel by CUT_AWAY option #2.

2.4 Indicators

User indications are provided that are active with a high level on the associated 56F801 device's I/O port. [Table 2-2](#) details the indicators.

Table 2-2. Indicators

| Indicator | 56F800 Signal | Color |
|-----------|---------------|--------|
| D1 | PWMA0 | Green |
| D2 | PWMA1 | Green |
| D3 | PWMA2 | Green |
| D4 | PWMA3 | Green |
| D5 | PWMA4 | Yellow |
| D6 | PWMA5 | Yellow |
| D7 | GPIOB1 / RXD0 | Yellow |
| D8 | GPIOB0 / TXD0 | Yellow |
| D9 | GPIOA1 / TD1 | Red |
| D10 | GPIOA2 / TD2 | Red |

Appendix A

56F800 Demonstration Board Schematics

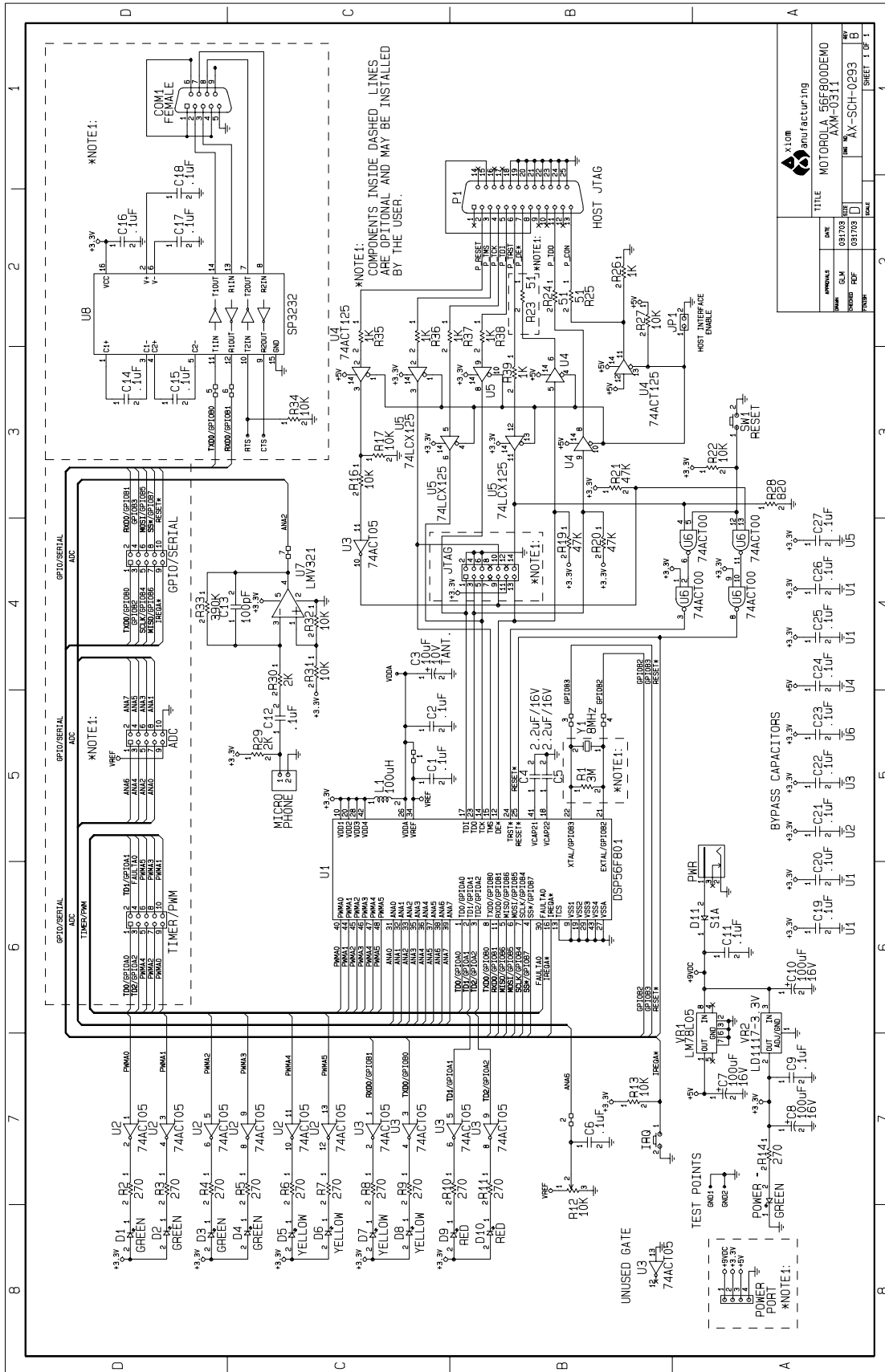

Figure A-1. 56F800 Demonstration Board

INDEX

A

ADC [vi](#), [2-1](#), [2-4](#)
 Analog-to-Digital Converter
 ADC [vi](#)

C

CE [v](#)
 Clear To Send
 CTS [vi](#)
 COM1 serial port [2-1](#)
 Crystal oscillator isolation [2-1](#)
 CTS [vi](#), [2-3](#)
 CUT_AWAY [v](#), [2-4](#), [2-5](#)

D

DS25 [2-4](#)
 DSP56F801 Digital Signal Processor User's Manual [vi](#)

E

Electrostatic Discharge
 ESD [v](#), [vi](#)
 EMC [v](#)
 ESD [v](#), [vi](#)

F

FCC [v](#)

G

General Purpose Input/Output Port
 GPIO [vi](#)
 GPIO [vi](#)

H

HOST_ENABLE [2-4](#)

I

I/O connector [v](#)
 I/O signal [v](#)

J

Joint Test Action Group
 JTAG [vi](#)
 JTAG [vi](#)

M

Microphone [2-2](#), [2-3](#)

O

OnCE [vi](#)
 On-Chip Emulation
 OnCE [vi](#)

P

PC [vi](#)
 Personal Computer
 PC [vi](#)
 POT [vi](#), [2-1](#), [2-3](#)
 Potentiometer
 POT [vi](#)
 Pulse Width Modulation
 PWM [vi](#)
 PWM [vi](#)

R

R23 [2-4](#)
 RS-232 [2-3](#)
 RTS [2-3](#)

T

Technical Data, 56F801 16-Bit Hybrid Controller [vi](#)