



Chipsmall Limited consists of a professional team with an average of over 10 year of expertise in the distribution of electronic components. Based in Hongkong, we have already established firm and mutual-benefit business relationships with customers from,Europe,America and south Asia,supplying obsolete and hard-to-find components to meet their specific needs.

With the principle of “Quality Parts,Customers Priority,Honest Operation,and Considerate Service”,our business mainly focus on the distribution of electronic components. Line cards we deal with include Microchip,ALPS,ROHM,Xilinx,Pulse,ON,Everlight and Freescale. Main products comprise IC,Modules,Potentiometer,IC Socket,Relay,Connector.Our parts cover such applications as commercial,industrial, and automotives areas.

We are looking forward to setting up business relationship with you and hope to provide you with the best service and solution. Let us make a better world for our industry!



## Contact us

Tel: +86-755-8981 8866 Fax: +86-755-8427 6832

Email & Skype: info@chipsmall.com Web: www.chipsmall.com

Address: A1208, Overseas Decoration Building, #122 Zhenhua RD., Futian, Shenzhen, China



## SPECIFICATIONS

### ELECTRICAL

USB

INPUT: 5V @ 25mA max

OUTPUT: USB1.1

### MECHANICAL

BALL DIAMETER: 2.25"

BALL ROTATION: Continuous

TRACKING FORCE: 12g

WEIGHT: 460g

LIFE CYCLE (BALL ROTATIONS): 5 Million

RoHS compliant

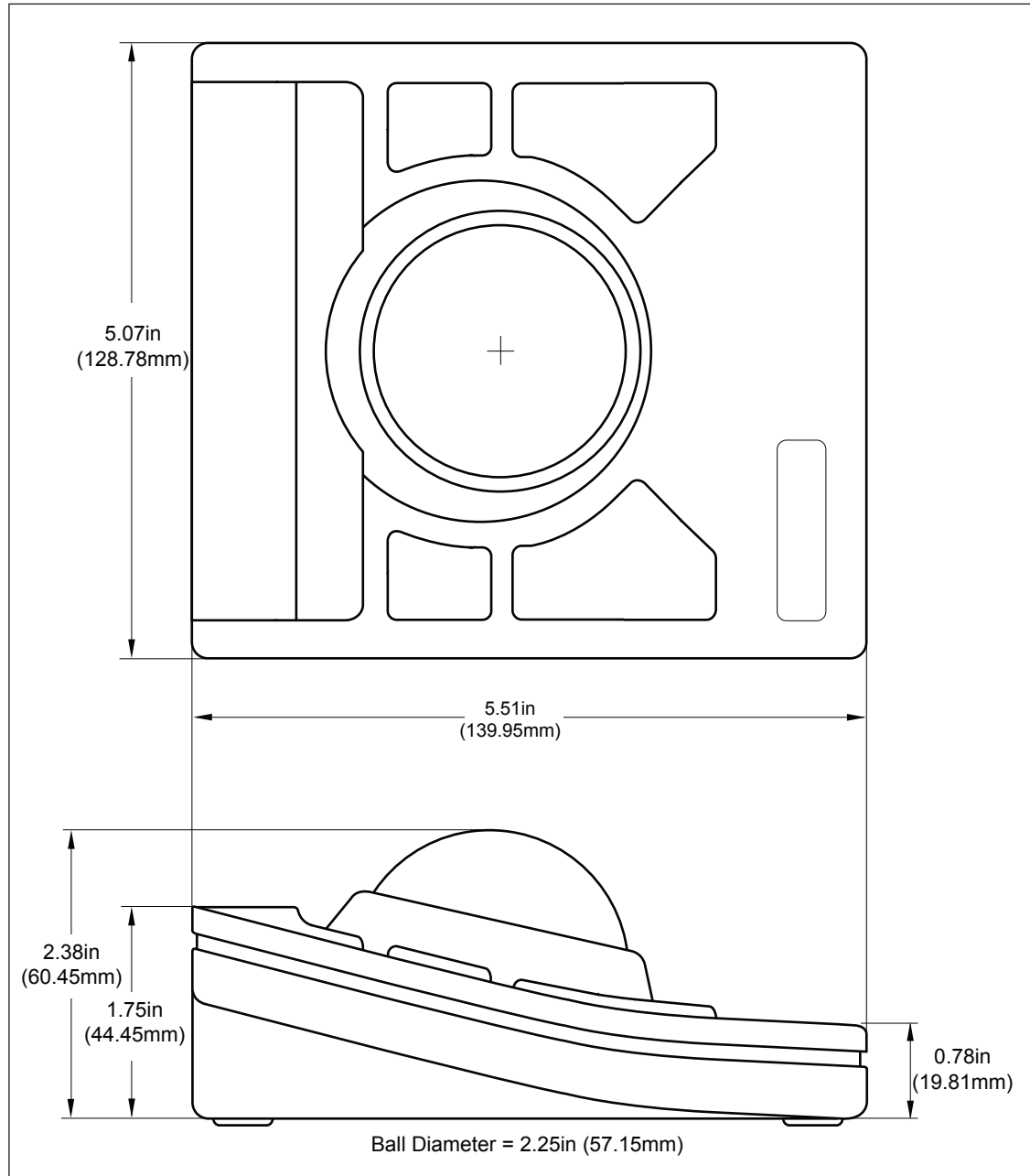

P/N	<b>DT2257X20V00-BIk</b>	REV	<b>A</b>
DESCRIPTION	DT225 Black Desktop Trackball, USB		
<p>PROPRIETARY AND CONFIDENTIAL          THE INFORMATION CONTAINED IN THIS DRAWING IS THE SOLE PROPERTY          OF CH PRODUCTS. ANY REPRODUCTION IN PART OR AS WHOLE WITHOUT          THE WRITTEN PERMISSION OF CH PRODUCTS IS PROHIBITED.</p>			