

Chipsmall Limited consists of a professional team with an average of over 10 year of expertise in the distribution of electronic components. Based in Hongkong, we have already established firm and mutual-benefit business relationships with customers from,Europe,America and south Asia,supplying obsolete and hard-to-find components to meet their specific needs.

With the principle of “Quality Parts,Customers Priority,Honest Operation,and Considerate Service”,our business mainly focus on the distribution of electronic components. Line cards we deal with include Microchip,ALPS,ROHM,Xilinx,Pulse,ON,Everlight and Freescale. Main products comprise IC,Modules,Potentiometer,IC Socket,Relay,Connector.Our parts cover such applications as commercial,industrial, and automotives areas.

We are looking forward to setting up business relationship with you and hope to provide you with the best service and solution. Let us make a better world for our industry!



Contact us

Tel: +86-755-8981 8866 Fax: +86-755-8427 6832

Email & Skype: info@chipsmall.com Web: www.chipsmall.com

Address: A1208, Overseas Decoration Building, #122 Zhenhua RD., Futian, Shenzhen, China

Digital transistors (built-in resistors)

DTC114EE / DTC114EUA / DTC114EKA

DTC114ECA / DTC114ESA

●Features

- 1) Built-in bias resistors enable the configuration of an inverter circuit without connecting external input resistors (see equivalent circuit).
- 2) The bias resistors consist of thin-film resistors with complete isolation to allow negative biasing of the input. They also have the advantage of almost completely eliminating parasitic effects.
- 3) Only the on/off conditions need to be set for operation, making device design easy.

●Structure

NPN digital transistor
(with built-in resistors)

●Equivalent circuit

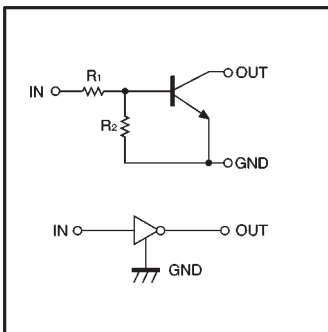

●External dimensions (Units: mm)

<p>DTC114EE</p> <p>ROHM : EMT3</p> <p>DTC114EUA</p> <p>ROHM : UMT3 EIAJ : SC-70</p>	<p>Abbreviated symbol : 24</p> <p>All terminals have same dimensions</p> <p>Abbreviated symbol : 24</p>	<p>(1) GND (2) IN (3) OUT</p> <p>(1) GND (2) IN (3) OUT</p>
<p>DTC114EKA</p> <p>ROHM : SMT3 EIAJ : SC-59</p>	<p>All terminals have same dimensions</p> <p>Abbreviated symbol : 24</p>	<p>(1) GND (2) IN (3) OUT</p>
<p>DTC114ECA</p> <p>ROHM : SST3</p>	<p>All terminals have same dimensions</p> <p>Abbreviated symbol : 24</p>	<p>(1) GND (2) IN (3) OUT</p>
<p>DTC114ESA</p> <p>ROHM : SPT EIAJ : SC-72</p>	<p>(1) (2) (3)</p>	<p>(1) GND (2) OUT (3) IN</p>

● Absolute maximum ratings (Ta=25°C)

Parameter	Symbol	Limits(DTC114E□)					Unit
		E	UA	KA	CA	SA	
Supply voltage	V _{CC}	50					V
Input voltage	V _{IN}	-10~+40					V
Output current	I _o	50					mA
	I _{C(Max.)}	100					
Power dissipation	P _d	150	200		300		mW
Junction temperature	T _J	150					°C
Storage temperature	T _{stg}	-55~+150					°C

● Electrical characteristics (Ta=25°C)

Parameter	Symbol	Min.	Typ.	Max.	Unit	Conditions
Input voltage	V _{I(off)}	—	—	0.5	V	V _{CC} =5V, I _o =100 μA
	V _{I(on)}	3	—	—		V _o =0.3V, I _o =10mA
Output voltage	V _{O(on)}	—	0.1	0.3	V	I _o /I _i =10mA/0.5mA
Input current	I _i	—	—	0.88	mA	V _i =5V
Output current	I _{o(off)}	—	—	0.5	μA	V _{CC} =50V, V _i =0V
DC current gain	G _i	30	—	—	—	V _o =5V, I _o =5mA
Input resistance	R _i	7	10	13	kΩ	—
Resistance ratio	R ₂ /R ₁	0.8	1	1.2	—	—
Transition frequency	f _t	—	250	—	MHz	V _{CE} =10V, I _E =-5mA, f=100MHz *

* Transition frequency of the device

● Packaging specifications

Part No.	Package	EMT3	UMT3	SMT3	SST3	SPT
	Packaging type	Taping	Taping	Taping	Taping	Taping
	Code	TL	T106	T146	T116	TP
	Basic ordering unit (pieces)	3000	3000	3000	3000	5000
DTC114EE		○	—	—	—	—
DTC114EUA		—	○	—	—	—
DTC114EKA		—	—	○	—	—
DTC114ECA		—	—	—	○	—
DTC114ESA		—	—	—	—	○

● Electrical characteristic curves

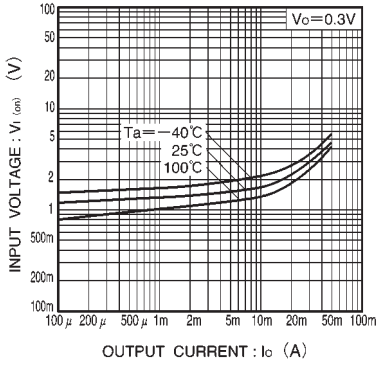

Fig.1 Input voltage vs. output current (ON characteristics)

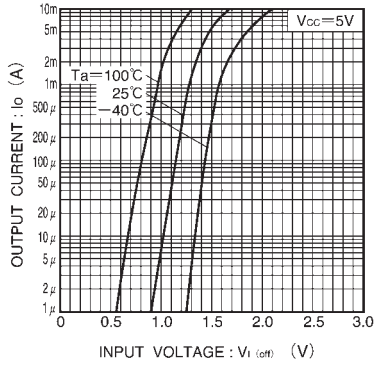

Fig.2 Output current vs. input voltage (OFF characteristics)

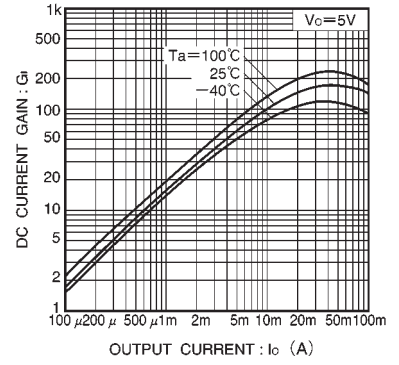

Fig.3 DC current gain vs. output current

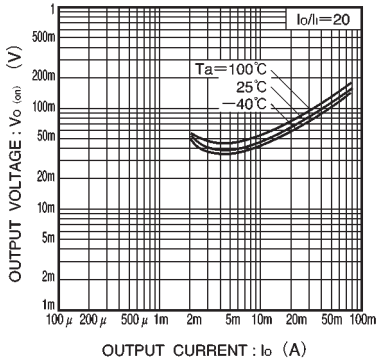

Fig.4 Output voltage vs. output current