



Chipsmall Limited consists of a professional team with an average of over 10 year of expertise in the distribution of electronic components. Based in Hongkong, we have already established firm and mutual-benefit business relationships with customers from,Europe,America and south Asia,supplying obsolete and hard-to-find components to meet their specific needs.

With the principle of “Quality Parts,Customers Priority,Honest Operation,and Considerate Service”,our business mainly focus on the distribution of electronic components. Line cards we deal with include Microchip,ALPS,ROHM,Xilinx,Pulse,ON,Everlight and Freescale. Main products comprise IC,Modules,Potentiometer,IC Socket,Relay,Connector.Our parts cover such applications as commercial,industrial, and automotives areas.

We are looking forward to setting up business relationship with you and hope to provide you with the best service and solution. Let us make a better world for our industry!



## Contact us

Tel: +86-755-8981 8866 Fax: +86-755-8427 6832

Email & Skype: info@chipsmall.com Web: www.chipsmall.com

Address: A1208, Overseas Decoration Building, #122 Zhenhua RD., Futian, Shenzhen, China



## Development Kit 91210-S008

The MLX91210 development kit provides all the needed components to evaluate the performances and the functionalities of MLX91210 integrated current sensor.

The kit includes:

- 1 demo PCB with 1 MLX91210 current sensor calibrated for 40mV/A
- 3 extra MLX91210 current sensors calibrated for 40mV/A

### Key features

#### Sensor:

- Isolated current measurement demo factory calibrated for 50A
- Qualified to voltage isolation 2.1-2.5kV in ref to UL and IEC norms
- Fully differential and stray field immune (insensitive to external field)

#### PCB:

- PCB design adapted to high current measurements<sup>1</sup>
- Ground Layer and Decoupling capacitors for high EMC performances
- Extra room for output filter implementation

### Sensor pin-out and connections

PCB components descriptions:

Part	Description	Value
C1	Supply capacitor, EMI , ESD	100nF
C2	Decoupling capacitor, EMI, ESD	10nF
C3, C4	Decoupling capacitor EMI, ESD	1nF
R1, R3	Extra Resistors for CRC filter	0 Ω
R2	Must-to-Gnd resistor	0 Ω
R4, C5	Extra RC filter	TBD

Pins designation:

VDD	Vout	Must	Vss	Ip+	Ip-
Supply	Analog	Digital	Ground	Analog	Analog
Supply Voltage (+5V)	Current Sensor Output (+/-2V)	Test and Factory Calibration	Supply Voltage	Current Input	Current Output

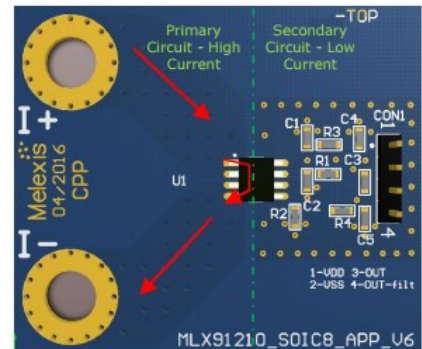
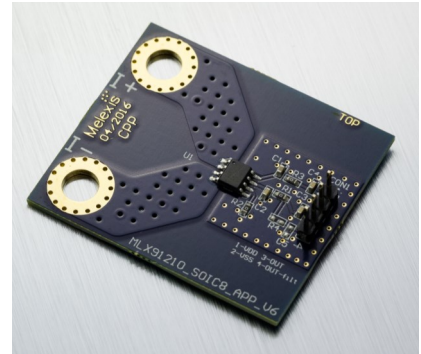

PCB top view

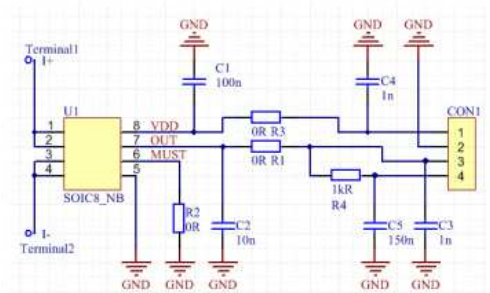

PCB schematic

<sup>1</sup>To avoid sensor overheating, max continuous RMS current < 30A. Detailed layout information on request (shu@melexis.com)

## Sensor Performances

- Very good non-linearity < 1%F.S.

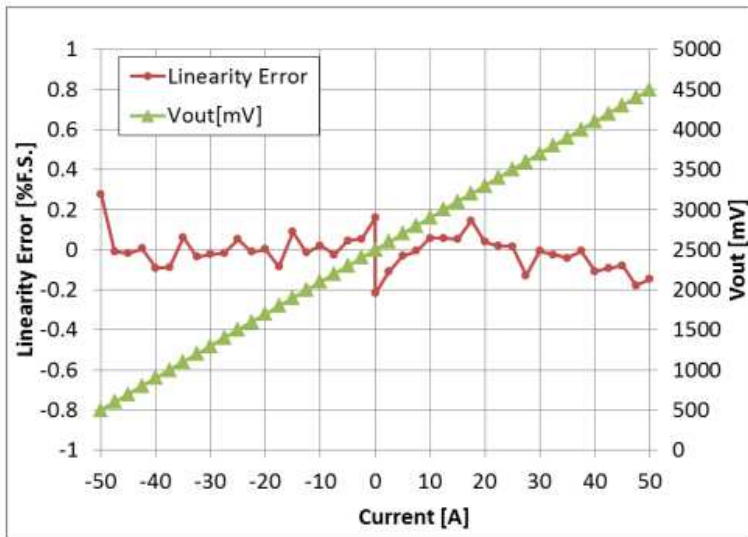

- Typical response time 5 $\mu$ s
- Additional RC filter:

Output	Filter	Bandwidth [kHz]	Noise [ $\mu$ Arms]
R4	C5		
n.a.	n.a.	100	0.15
100	150	10	0.05
1000	150	1	0.02

- On-chip Sensitivity Drift and Offset Drift compensation over lifetime and temperature
  - ⇒ Sensitivity Drift : +/-1%
  - ⇒ Offset Drift : +/-0.12A

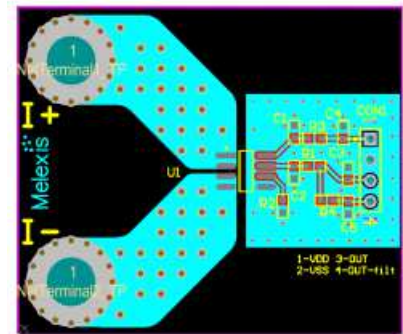

PCB Layout

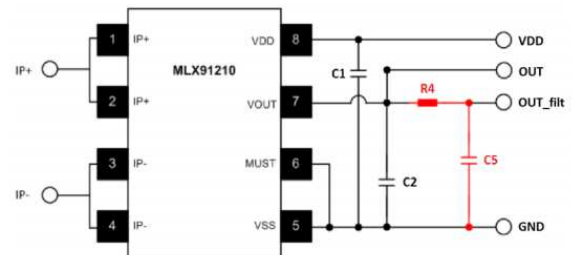

Pin-out for MLX91210-SOIC08 (R1, R2, R3, R4, C3,C4, no represented)

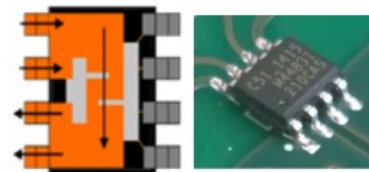

### Disclaimer:

Devices sold by Melexis are covered by the warranty and patent indemnification provisions appearing in its Term of Sale. Melexis makes no warranty, express, statutory, implied, or by description regarding the information set forth herein or regarding the freedom of the described devices from patent infringement. Melexis reserves the right to change specifications and prices at any time and without notice. Therefore, prior to designing this product into a system, it is necessary to check with Melexis for current information. This product is intended for use in normal commercial applications. Applications requiring extended temperature range, unusual environmental requirements, or high reliability applications, such as military, medical life-support or life-sustaining equipment are specifically not recommended without additional processing by Melexis for each application. The information furnished by Melexis is believed to be correct and accurate. However, Melexis shall not be liable to recipient or any third party for any damages, including but not limited to personal injury, property damage, loss of profits, loss of use, interrupt of business or indirect, special incidental or consequential damages, of any kind, in connection with or arising out of the furnishing, performance or use of the technical data herein. No obligation or liability to recipient or any third party shall arise or flow out of Melexis' rendering of technical or other services. © 2010 Melexis NV. All rights reserved.