



Chipsmall Limited consists of a professional team with an average of over 10 year of expertise in the distribution of electronic components. Based in Hongkong, we have already established firm and mutual-benefit business relationships with customers from,Europe,America and south Asia,supplying obsolete and hard-to-find components to meet their specific needs.

With the principle of “Quality Parts,Customers Priority,Honest Operation,and Considerate Service”,our business mainly focus on the distribution of electronic components. Line cards we deal with include Microchip,ALPS,ROHM,Xilinx,Pulse,ON,Everlight and Freescale. Main products comprise IC,Modules,Potentiometer,IC Socket,Relay,Connector.Our parts cover such applications as commercial,industrial, and automotives areas.

We are looking forward to setting up business relationship with you and hope to provide you with the best service and solution. Let us make a better world for our industry!



Contact us

Tel: +86-755-8981 8866 Fax: +86-755-8427 6832

Email & Skype: info@chipsmall.com Web: www.chipsmall.com

Address: A1208, Overseas Decoration Building, #122 Zhenhua RD., Futian, Shenzhen, China





• Features

- Maintenance-free**
 Unlike a relay control panel, wiring is not necessary. Contactless configuration requires no maintenance.
- Various motor capacities can be selected.**
 Can support 1 W to 90 W motors. With 40 W or larger motors, selection can be made with the brake torque switch. Brake resistor is not required and wiring is simplified.
- Easier standardization of panel design**
 Control panel can be sized to DIN standard at lower total cost.
- Various options**
 One option, mounting frame, for example, allows installation of the unit on the panel.
- Soft-braking capability**
 The brake torque switch has "LOW" position. In this position, the brake torque is reduced.
- Braking time**
 Time is simply adjustable from the selector switch.

• Specification

Item	Part No.	DVMB481L	DVMB481Y	DVMB48RL	DVMB48RY	DVMB48BL	DVMB48BY
Rated voltage		Single-phase 100 VAC	Single-phase 200 VAC	Single-phase 100 VAC	Single-phase 200 VAC	Single-phase 100 VAC	Single-phase 200 VAC
Operating voltage		±10% at rated voltage					
Power frequency		50/60 Hz					
Applicable motor		Induction motor		Reversible motor		Electromagnetic brake motor	
Selection of applicable motor		Selectable from changeover switch		• 1 W to 25 W • 40 W to 90 W • LOW		---	
Electric brake operating time		Selectable from changeover switch		2/0.5/0.2 sec		---	
Normal/reverse rotation		×		○		○	
Electric brake		○		○		×	
Electromagnetic brake drive		×		×		○	
Control voltage input		DC12 to 24 V (±10%)					
Operating temperature		-10°C to 40°C					
Storage temperature		-20°C to 60°C					
Operating humidity		85% RH or below (no dewing)					

[Notes]

- Electric braking system has no holding torque.
- Reversible motor is provided with a simple constant sliding brake with slight holding force. For application requiring larger holding force, use Panasonic electromagnetic brake motor.
- When braking a load with excessively large inertia, related issues are strength and life of motor shaft and gear. For these subjects, consult us.
- When using motor other than compact geared motor, consult us.

* Please read your User's manual carefully so that you will understand the operation and safety precautions before attempting to operate the system.

• Names and functions

For induction motor

For reversible motor

For electromagnetic brake motor

Name	Functional description
1 CW lamp	Indicates that the motor output shaft is rotating CW.
2 CCW lamp	Indicates that the motor output shaft is rotating CCW.
3 BRAKE lamp	Indicates that the electric brake is being applied.
4 RUN lamp	Indicates that the motor is operating.
5 BRAKE RELEASE lamp	Indicates that current is flowing through the electromagnetic brake. (Brake is released as the electromagnetic brake is energized.)
6 BRAKE TIME selector	Adjust the application time of electric brake according to inertia of the load. Standard setting is 0.2 sec (recommended)
7 BRAKE TORQUE selector (selection of motor output)	1 W to 25 W For motor of 1 W to 25 W 40 W to 90 W For motor of 40 W to 90 W Low To reduce impact during braking with motor of 1 W to 90 W

• Outline drawing

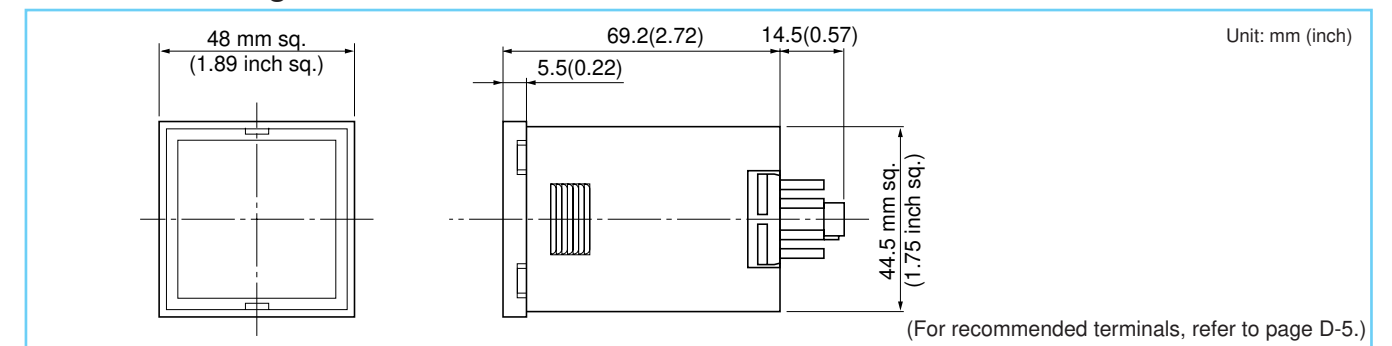

• Fundamental electrical wiring diagram (induction motor)

<Wiring diagram>

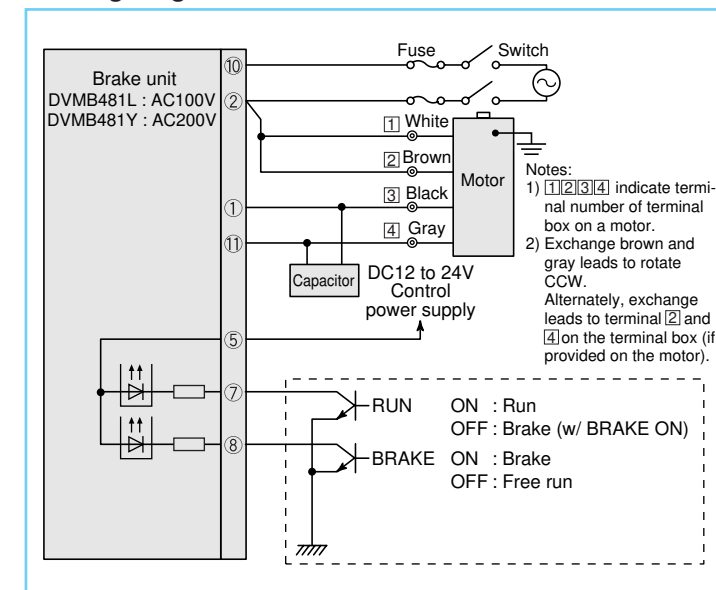

<Operating method>

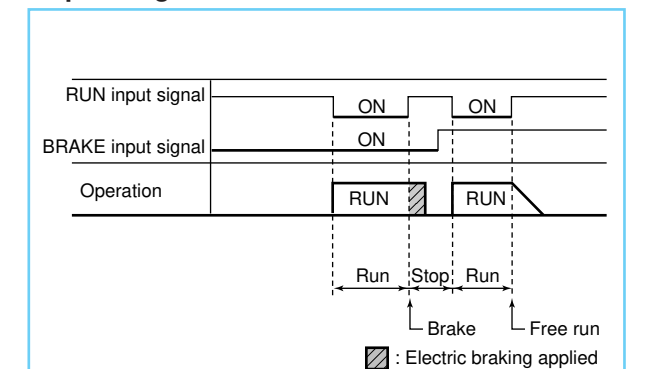

[Notes]

- Connect the brake unit only to a single motor.
- The thick continuous lines represent main circuit. Use conductor of size approx. 0.75 mm².
- Never input RUN signal while electric braking is applied.

* Please read your User's manual carefully so that you will understand the operation and safety precautions before attempting to operate the system.

• Fundamental electrical wiring diagram (reversible motor)

<Wiring diagram>

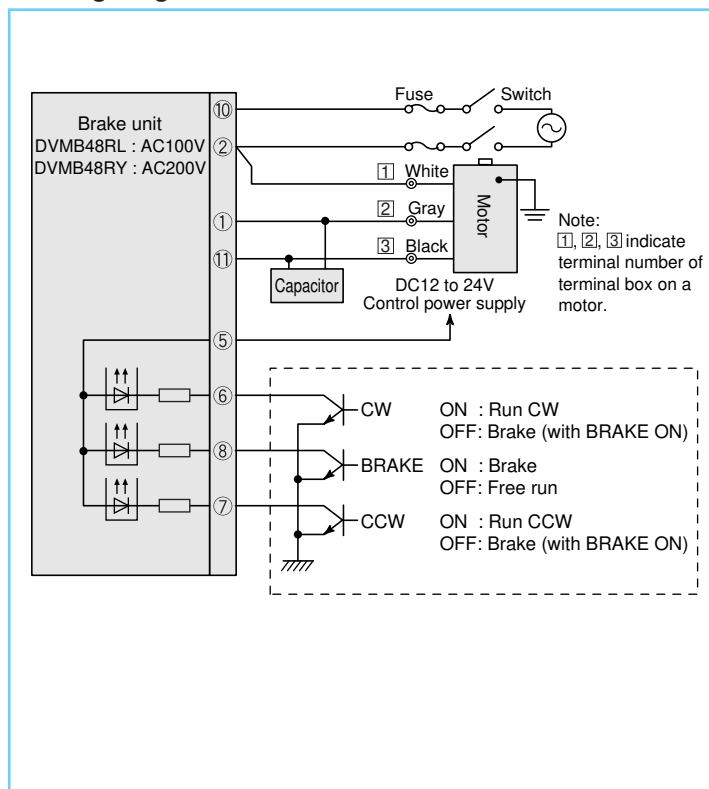

<Operating method>

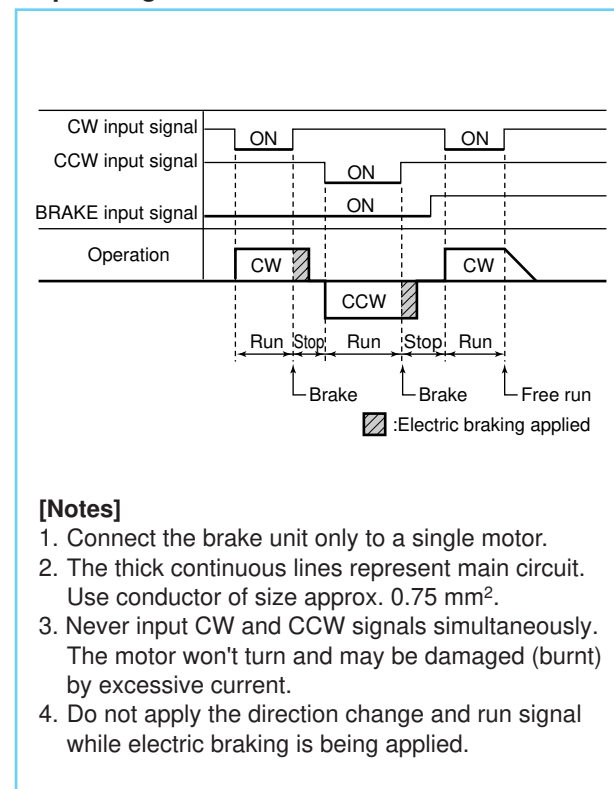

• Fundamental electrical wiring diagram (electromagnetic brake motor)

<Wiring diagram>

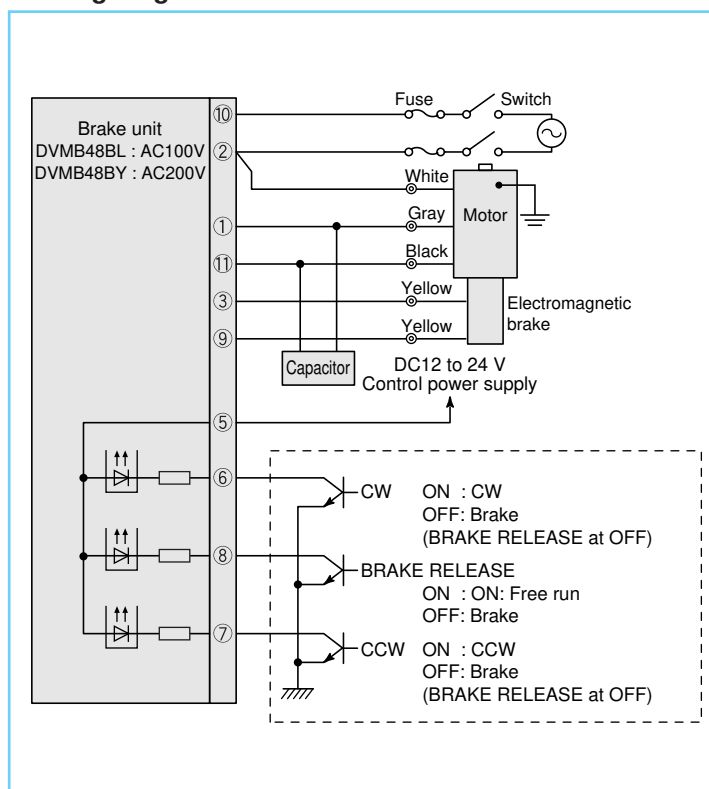

<Operating method>

