



Chipsmall Limited consists of a professional team with an average of over 10 year of expertise in the distribution of electronic components. Based in Hongkong, we have already established firm and mutual-benefit business relationships with customers from,Europe,America and south Asia,supplying obsolete and hard-to-find components to meet their specific needs.

With the principle of “Quality Parts,Customers Priority,Honest Operation,and Considerate Service”,our business mainly focus on the distribution of electronic components. Line cards we deal with include Microchip,ALPS,ROHM,Xilinx,Pulse,ON,Everlight and Freescale. Main products comprise IC,Modules,Potentiometer,IC Socket,Relay,Connector.Our parts cover such applications as commercial,industrial, and automotives areas.

We are looking forward to setting up business relationship with you and hope to provide you with the best service and solution. Let us make a better world for our industry!



Contact us

Tel: +86-755-8981 8866 Fax: +86-755-8427 6832

Email & Skype: info@chipsmall.com Web: www.chipsmall.com

Address: A1208, Overseas Decoration Building, #122 Zhenhua RD., Futian, Shenzhen, China



版数 REV.	年月日 DATE	図 No.	変更内容 DESCRIPTION	製図 DR.	担当 CHK.	査閲 APPD.	承認 APPD.
2	31/0CT/2013	006471	DELETION OF RATED CURRENT/VOLTAGE MARKING 定格電流/電圧表示の削除(改版マ-: 3回)	-	K. NAKAZAWA	Y. ITOU	T. KUDOU

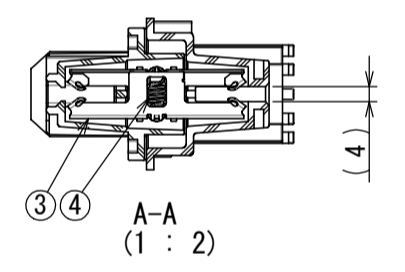
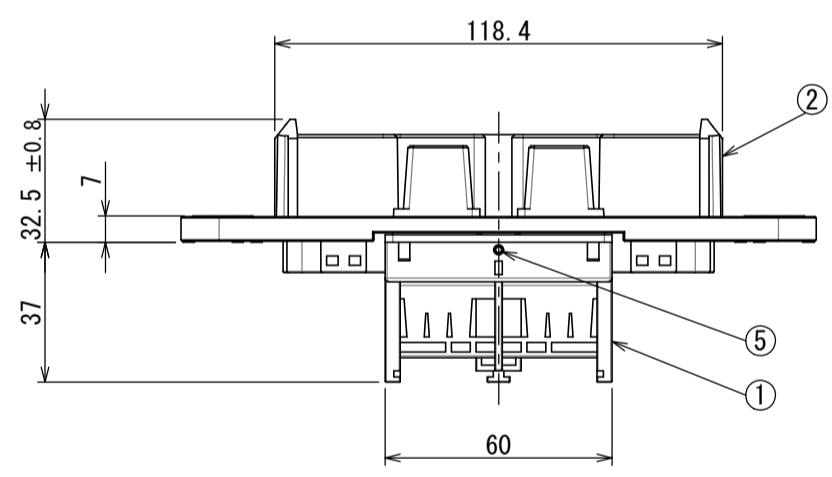
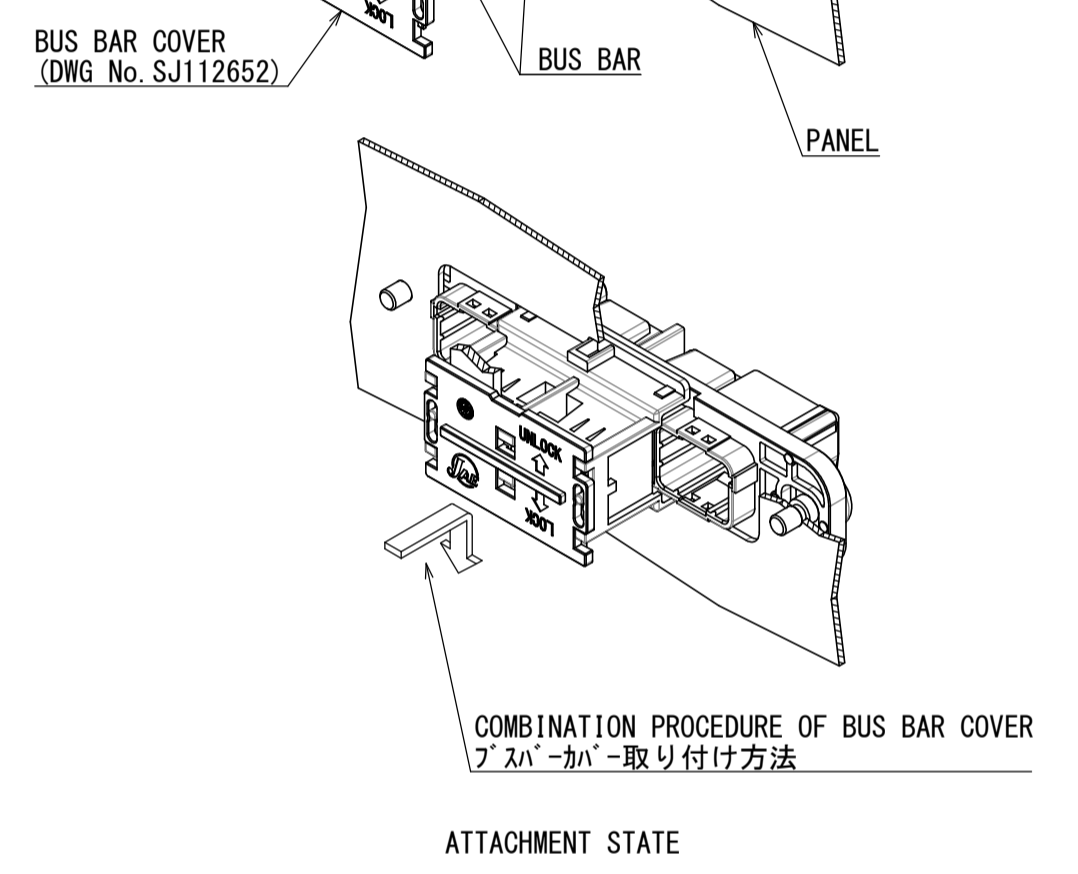
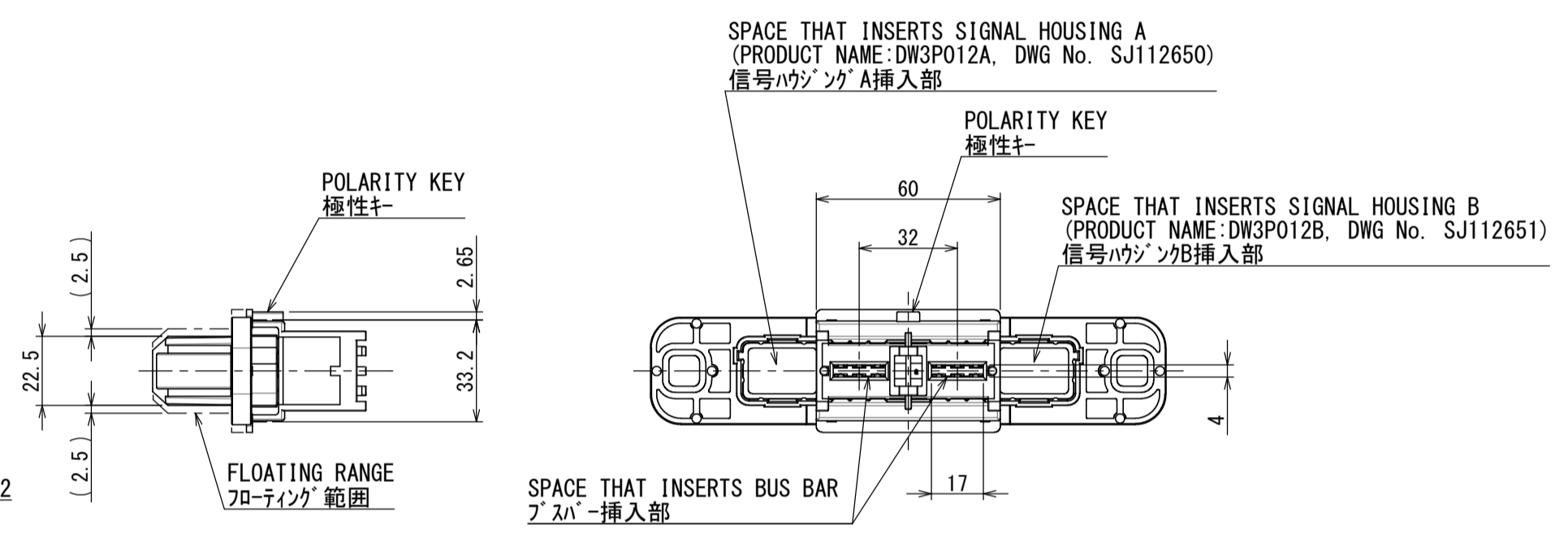
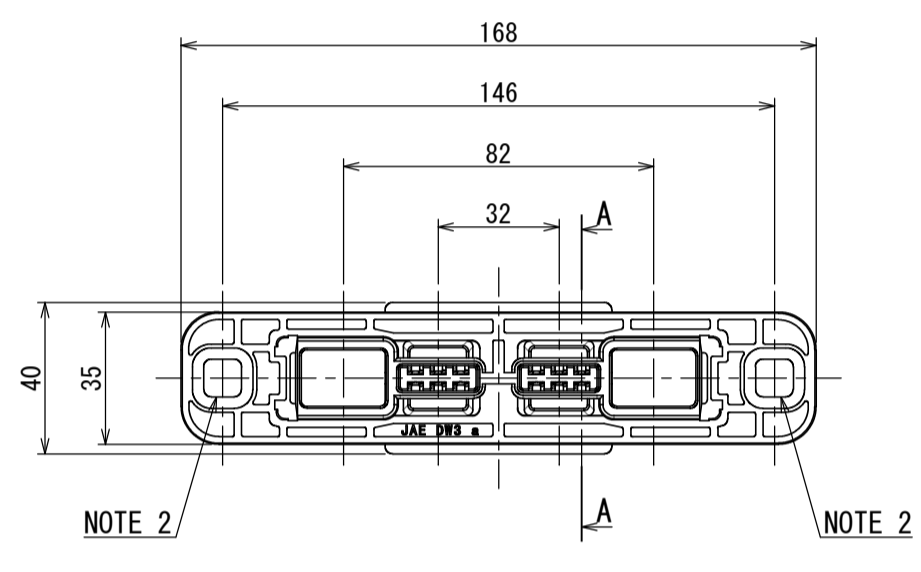
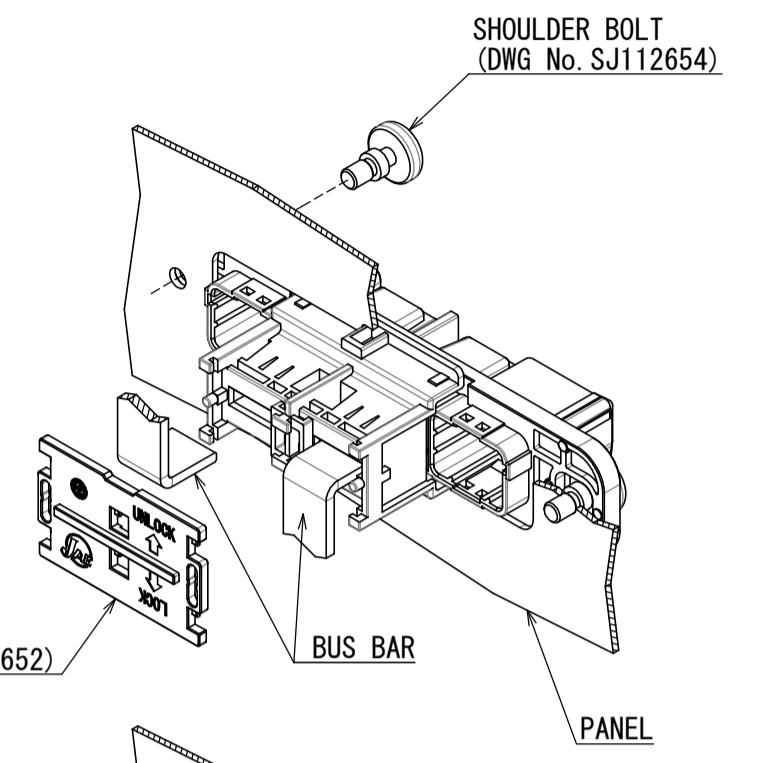
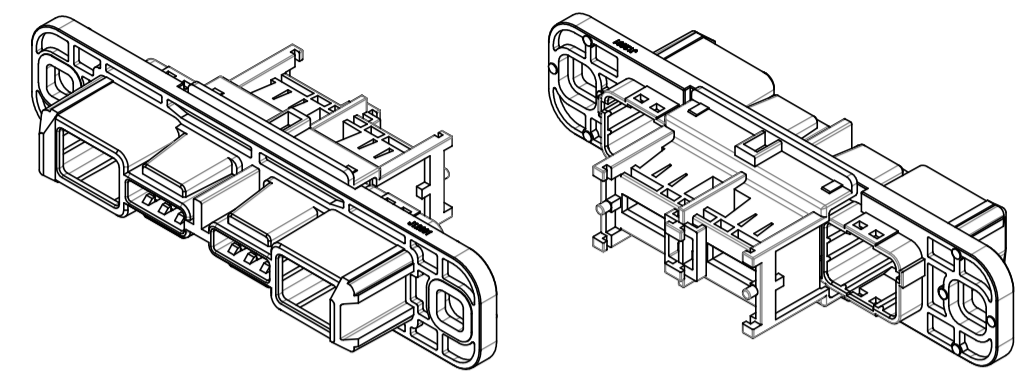
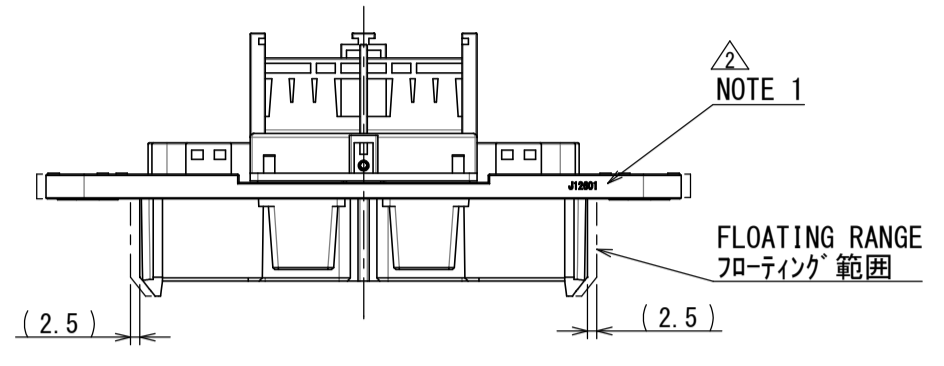

MATERIAL: HIGH CONDUCTIVITY COPPER ALLOY
FINISH: SILVER PLATING (3.0 μm ~ 8.5 μm)

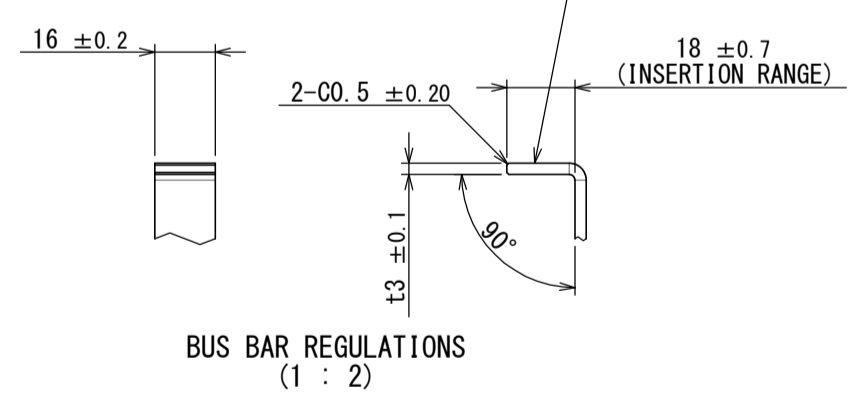

- △ NOTE 1. PRODUCTION LOT NUMBER IS SHOWN AT THIS LOCATION.
NOTE 2. THROUGH HOLE FOR ATTACHMENT SHOULDER BOLT (DWG No. SJ112654).
TIGHTEN SHOULDER BOLT WITH 5.2 [N·m] ± 0.5 [N·m].
NOTE 3. DON'T PUT THE FOREIGN BODY IN THE CONNECTOR MOVABLE RANGE.
- △ 注1. 図示の位置に製造ロットを表示する。
注2. 取り付けショルダ-ボルト(図番: SJ112654)用貫通穴
ショルダ-ボルト締め付けトルク: 5.2 [N·m] ± 0.5 [N·m].
注3. コネクタ移動範囲のため異物を設けないこと。

特別管理品目
SPECIAL CONTROL ITEM
Li電池

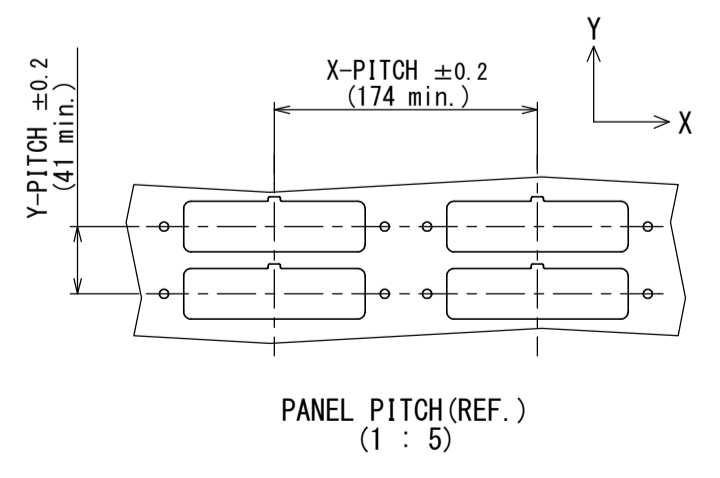
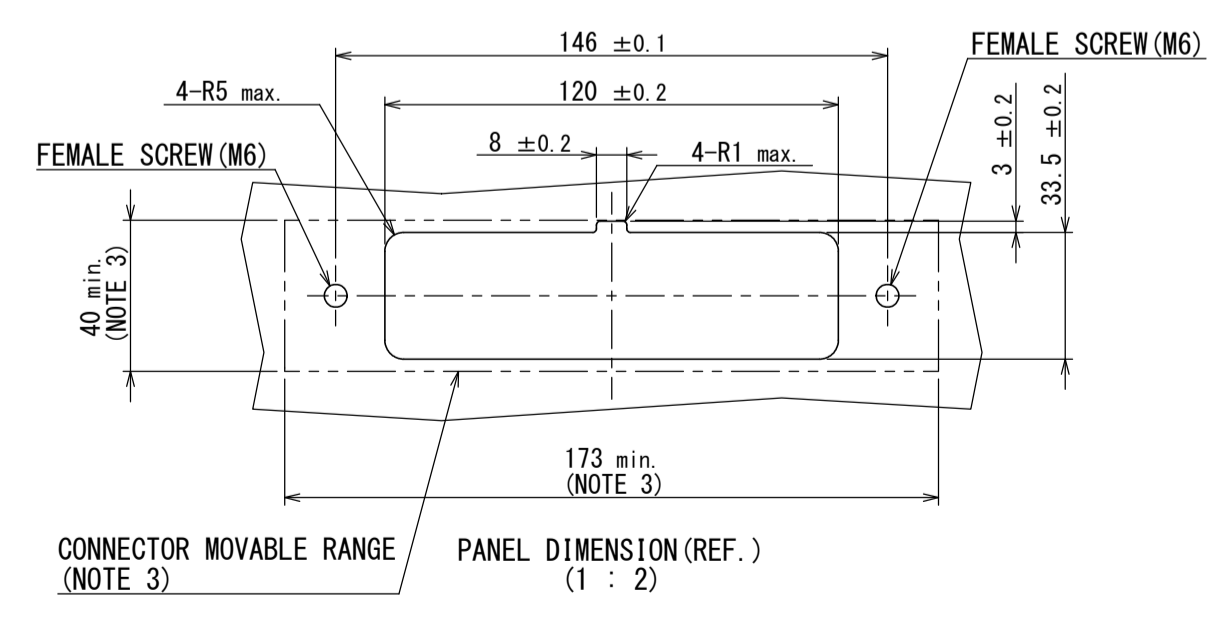

5	SPRING PIN	1	STAINLESS STEEL	-	-
4	HELICAL EXTENSION SPRING	6	STAINLESS STEEL	-	-
3	FLOATING CONTACT	12	COPPER ALLOY	SILVER PLATING	-
2	FLOATING HOUSING	1	PBT	COLOR : BLACK	-
1	BASE HOUSING	1	PBT	COLOR : BLACK	-

符号 No.	名称 DESCRIPTION	個数 QTY.	材料 MATERIAL	仕上 FINISH	備考 REMARKS
5	SPRING PIN	1	STAINLESS STEEL	-	-
4	HELICAL EXTENSION SPRING	6	STAINLESS STEEL	-	-
3	FLOATING CONTACT	12	COPPER ALLOY	SILVER PLATING	-
2	FLOATING HOUSING	1	PBT	COLOR : BLACK	-
1	BASE HOUSING	1	PBT	COLOR : BLACK	-

仕様書 (SPECIFICATION)	第1版 (ORIGINAL DATE)	尺度 (SCALE)	シリーズ (SERIES)
JACS-30260 JAHL-30260	01/JUN/2012	1:2	DW3
製図 DR.	担当 CHK.	名称 (TITLE)	日本航空電子工業株式会社
-	K. NAKAZAWA	DW3R002ZH1	JAE CONNECTOR Co., Ltd.
一般公差 (GENERAL TOLERANCE)	査閲 APPD.	FLOATING CONNECTOR	JAPAN AVIATION ELECTRONICS INDUSTRY, LTD.
寸法 (DIMENSION)	承認 APPD.		
. ± 0.8	T. KUDOU		
. × ± 0.4			
. × × ± 0.1			
. × × × ±			
		質量 (MASS)	図面番号 (DRAWING NO.)
			SJ112647
			版数 (REV.)
			2