



Chipsmall Limited consists of a professional team with an average of over 10 year of expertise in the distribution of electronic components. Based in Hongkong, we have already established firm and mutual-benefit business relationships with customers from,Europe,America and south Asia,supplying obsolete and hard-to-find components to meet their specific needs.

With the principle of “Quality Parts,Customers Priority,Honest Operation,and Considerate Service”,our business mainly focus on the distribution of electronic components. Line cards we deal with include Microchip,ALPS,ROHM,Xilinx,Pulse,ON,Everlight and Freescale. Main products comprise IC,Modules,Potentiometer,IC Socket,Relay,Connector.Our parts cover such applications as commercial,industrial, and automotives areas.

We are looking forward to setting up business relationship with you and hope to provide you with the best service and solution. Let us make a better world for our industry!



Contact us

Tel: +86-755-8981 8866 Fax: +86-755-8427 6832

Email & Skype: info@chipsmall.com Web: www.chipsmall.com

Address: A1208, Overseas Decoration Building, #122 Zhenhua RD., Futian, Shenzhen, China



2 x 37 W dual/quad power amplifier for car radio

Features

- High output power capability
 - 2 x 43 W max./4 Ω
 - 2 x 37 W/4 Ω EIAJ
 - 2 x 26 W/4 Ω @14.4 V, 1 kHz, 10 %
 - 4 x 7 W/4 Ω @14.4 V, 1 kHz, 10 %
 - 4 x 12 W/2 Ω @14.4 V, 1 kHz, 10 %
- Minimum external components count:
 - No bootstrap capacitors
 - No Boucherot cells
 - Internally fixed gain (26 dB BTL)
 - Standby function (CMOS compatible)
- No audible pop during standby operations
- Diagnostics facility for:
 - Clipping
 - Out to GND short
 - Out to V_S short
 - Soft short at turn-on
 - Thermal shutdown proximity
- Protections:
 - Output AC/DC short circuit: to GND, to V_S and across the load
 - Soft short at turn-on
 - Overrating chip temperature with soft thermal limiter
 - Load dump voltage surge

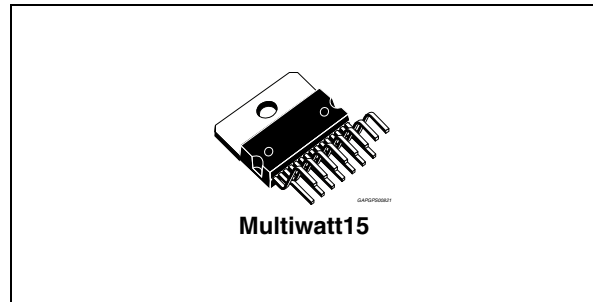

- Very inductive loads
- Fortuitous open GND
- Reversed battery
- ESD

Description

The TDA7375AV is a technology class AB car radio amplifier able to work either in dual bridge or quad single ended configuration.

The exclusive fully complementary structure of the output stage and the internally fixed gain guarantee the highest possible power performances with extremely reduced component count.

The on-board clip detector simplifies gain compression operation. The fault diagnostics makes it possible to detect mistakes during car radio set assembly and wiring in the car.

Table 1. Device summary

Order code	Package	Packing
E-TDA7375AV	Multiwat15	Tube

Contents

- 1 Block and pin connection diagrams 5**
- 2 Electrical specification 6**
 - 2.1 Absolute maximum ratings 6
 - 2.2 Thermal data 6
 - 2.3 Electrical characteristics 6
- 3 Standard test and application circuits 8**
 - 3.1 Electrical characteristics curves 10
- 4 Functional description 13**
 - 4.1 High application flexibility 13
 - 4.2 Easy single ended to bridge transition 13
 - 4.3 Gain internally fixed to 20 dB in single ended, 26 dB in bridge 13
 - 4.4 Silent turn on/off and muting/standby function 13
 - 4.5 Output stage 13
 - 4.5.1 Rail-to-rail output voltage swing with no need of bootstrap capacitors . 14
 - 4.5.2 Absolute stability without any external compensation 14
 - 4.6 Built-in short circuit protection 14
 - 4.6.1 Diagnostics facility 15
 - 4.6.2 Thermal shutdown 15
 - 4.7 Handling of the diagnostics information 16
- 5 Package information 18**
- 6 Revision history 19**

List of tables

Table 1.	Device summary	1
Table 2.	Absolute maximum ratings	6
Table 3.	Thermal data	6
Table 4.	Electrical characteristics	6
Table 5.	Document revision history	19

List of figures

Figure 1.	Block diagram	5
Figure 2.	Pin connection (top view)	5
Figure 3.	Quad stereo circuit	8
Figure 4.	Double bridge circuit	8
Figure 5.	Stereo/bridge circuit	8
Figure 6.	PCB and component layout of the Figure 3	9
Figure 7.	PCB and component layout of the Figure 4	9
Figure 8.	Quiescent drain current vs. supply voltage (Single ended and bridge).	10
Figure 9.	Quiescent output voltage vs. supply voltage (Single ended and bridge)	10
Figure 10.	Output power vs. supply voltage (2 Ω , S.E.)	10
Figure 11.	Output power vs. supply voltage (4 Ω , S.E.)	10
Figure 12.	Output power vs. supply voltage (4 Ω , BTL)	10
Figure 13.	Distortion vs. output power (2 Ω , S.E.)	10
Figure 14.	Distortion vs. output power (4 Ω , S.E.)	11
Figure 15.	Distortion vs. output power (4 Ω , BTL)	11
Figure 16.	Crosstalk vs. frequency	11
Figure 17.	Supply voltage rejection vs. frequency (BTL)	11
Figure 18.	Supply voltage rejection vs. frequency (S.E.)	11
Figure 19.	Standby attenuation vs. threshold voltage	11
Figure 20.	Total power dissipation and efficiency vs. output power (S.E.)	12
Figure 21.	Total power dissipation and efficiency vs. output power (BTL)	12
Figure 22.	The new output stage	14
Figure 23.	Single ended configuration	15
Figure 24.	Clipping detection waveforms	15
Figure 25.	Output fault waveforms (see Figure 26)	16
Figure 26.	Fault waveforms	16
Figure 27.	Waveforms	17
Figure 28.	Interface circuitry to differentiate the information schematic.	17
Figure 29.	Multiwatt 15 mechanical data and package dimensions.	18

1 Block and pin connection diagrams

Figure 1. Block diagram

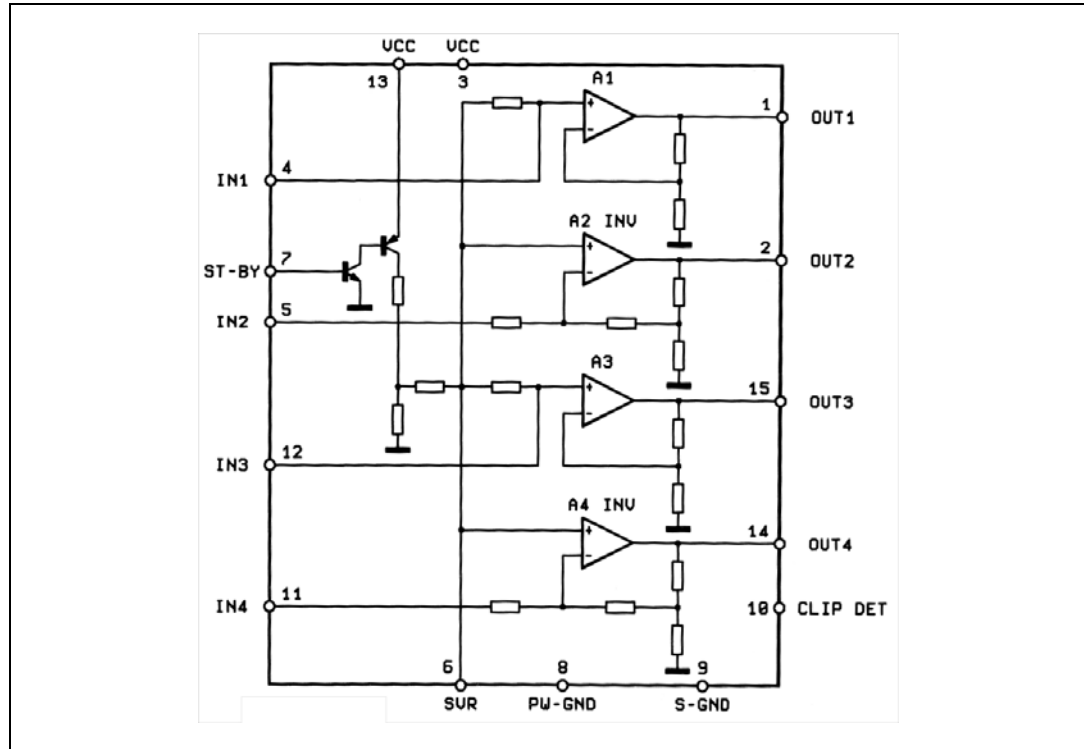
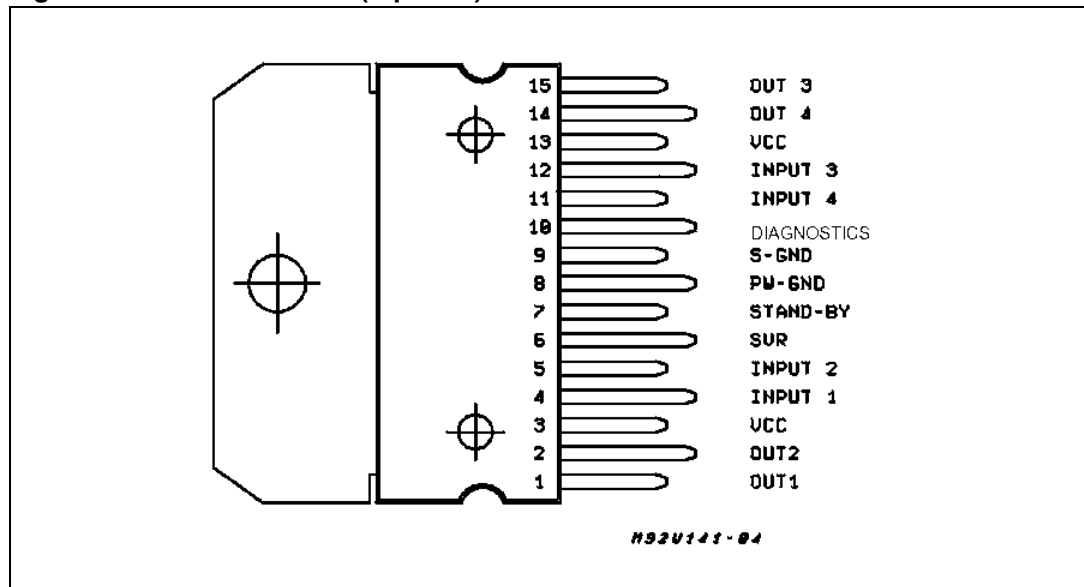

Figure 2. Pin connection (top view)



2 Electrical specification

2.1 Absolute maximum ratings

Table 2. Absolute maximum ratings

Symbol	Parameter	Value	Unit
V_{op}	Operating supply voltage	18	V
V_S	DC supply voltage	28	V
V_{peak}	Peak supply voltage (for $t = 50$ ms)	40	V
I_O	Output peak current (not repetitive $t = 100$ μ s)	4.5	A
I_O	Output peak current (repetitive $f > 10$ Hz)	3.5	A
P_{tot}	Power dissipation ($T_{case} = 85$ °C)	36	W
T_{stg}, T_j	Storage and junction temperature	-40 to 150	°C

2.2 Thermal data

Table 3. Thermal data

Symbol	Parameter	Value	Unit
$R_{th\ j-case}$	Thermal resistance junction-to-case	max 1.8	°C/W

2.3 Electrical characteristics

Refer to the test circuit, $V_S = 14.4$ V; $R_L = 4$ Ω ; $f = 1$ kHz; $T_{amb} = 25$ °C, unless otherwise specified.

Table 4. Electrical characteristics

Symbol	Parameter	Test condition	Min.	Typ.	Max.	Unit
V_S	Supply voltage range	-	8	-	18	V
I_d	Total quiescent drain current	$R_L = \infty$	-	-	150	mA
V_{OS}	Output offset voltage	-	-	-	150	mV
P_O	Output power	THD = 10 %; $R_L = 4$ Ω Bridge Single Ended Single Ended, $R_L = 2$ Ω	23 6.5	25 7 12	-	W W W
$P_{O\ max}$	Max. output power ⁽¹⁾	$V_S = 14.4$ V, Bridge	37	43	-	W
$P_{O\ EIAJ}$	EIAJ output power ⁽¹⁾	$V_S = 13.7$ V, Bridge	33	37	-	W
THD	Distortion	$R_L = 4$ Ω Single Ended, $P_O = 0.1$ to 4 W Bridge, $P_O = 0.1$ to 10 W	-	0.02 0.03	- 0.3	% %

Table 4. Electrical characteristics (continued)

Symbol	Parameter	Test condition	Min.	Typ.	Max.	Unit
C _T	Cross talk	f = 1 kHz Single ended	-	70	-	dB
		f = 10 kHz Single ended	-	60	-	dB
		f = 1 kHz Bridge	55	-	-	dB
		f = 10 kHz Bridge	-	60	-	dB
R _{IN}	Input impedance	Single Ended	20	30	-	kΩ
		Bridge	10	15	-	kΩ
G _V	Voltage gain	Single Ended	19	20	21	dB
		Bridge	25	26	27	dB
G _V	Voltage gain match	-	-	0.5	dB	
E _{IN}	Input noise voltage	R _g = 0; "A" weighted, S.E. Non inverting channels	-	2	-	μV
		Inverting channels	-	5	-	μV
		Bridge R _g = 0; 22 Hz to 22 kHz	-	3.5	-	μV
SVR	Supply voltage rejection	R _g = 0; f = 300 Hz	50	-	-	dB
A _{SB}	Standby attenuation	P _O = 1 W	80	90	-	dB
I _{SB}	Standby current consumption	V _{St-by} = 0 to 1.5 V	-	-	100	μA
V _{SB}	Standby In threshold voltage		-	-	1.5	V
V _{SB}	Standby Out threshold voltage		3.5	-	-	V
I _{pin7}	Standby pin current	Play mode V _{pin7} = 5 V	-	-	50	μA
		Max. driving current under fault ⁽²⁾	-	-	5	mA
I _{cd off}	Clipping detector output average current	d = 1% ⁽³⁾	-	90	-	μA
I _{cd on}	Clipping detector output average current	d = 5% ⁽³⁾	-	160	-	μA
V _{sat pin10}	Voltage saturation on pin 10	Sink current at Pin 10 = 1 mA	-	-	0.7	V

1. Saturated square wave output.

2. See built-in S/C protection description

3. Pin 10 pulled-up to 5 V with 10 kΩ; R_L = 4 Ω

3 Standard test and application circuits

Figure 3. Quad stereo circuit

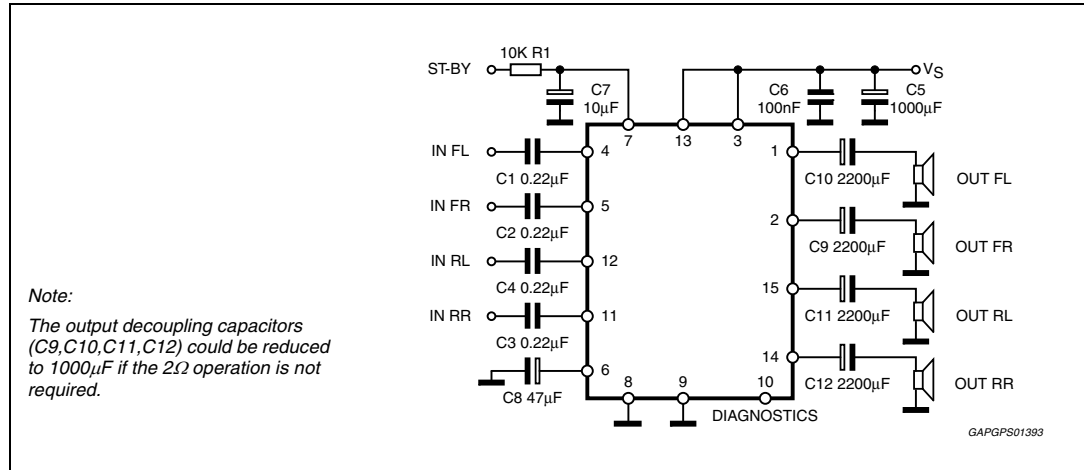

Figure 4. Double bridge circuit

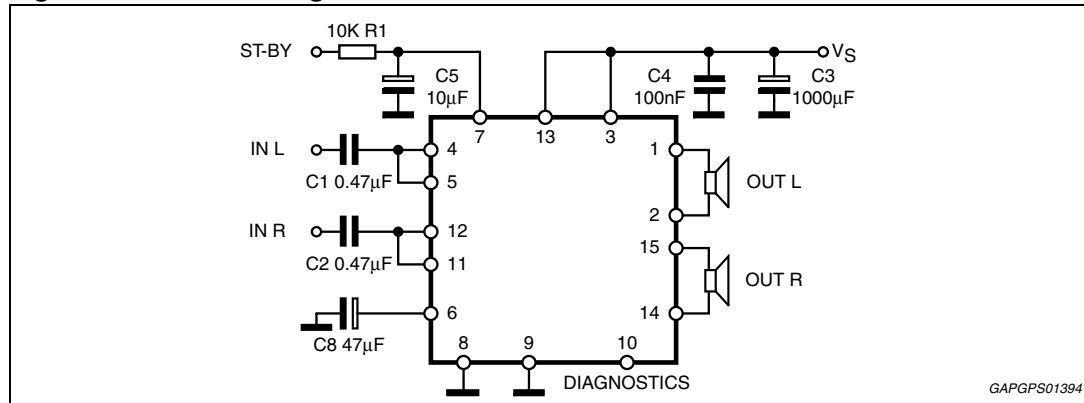

Figure 5. Stereo/bridge circuit

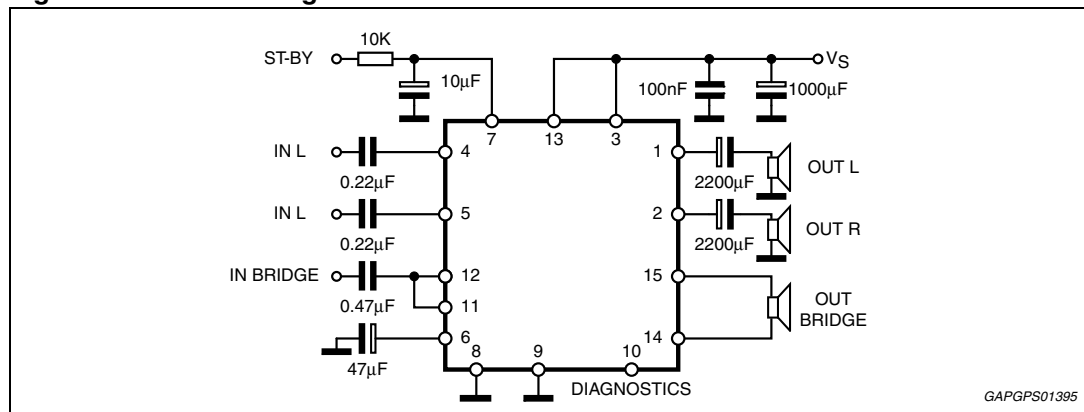

Figure 6. PCB and component layout of the *Figure 3*

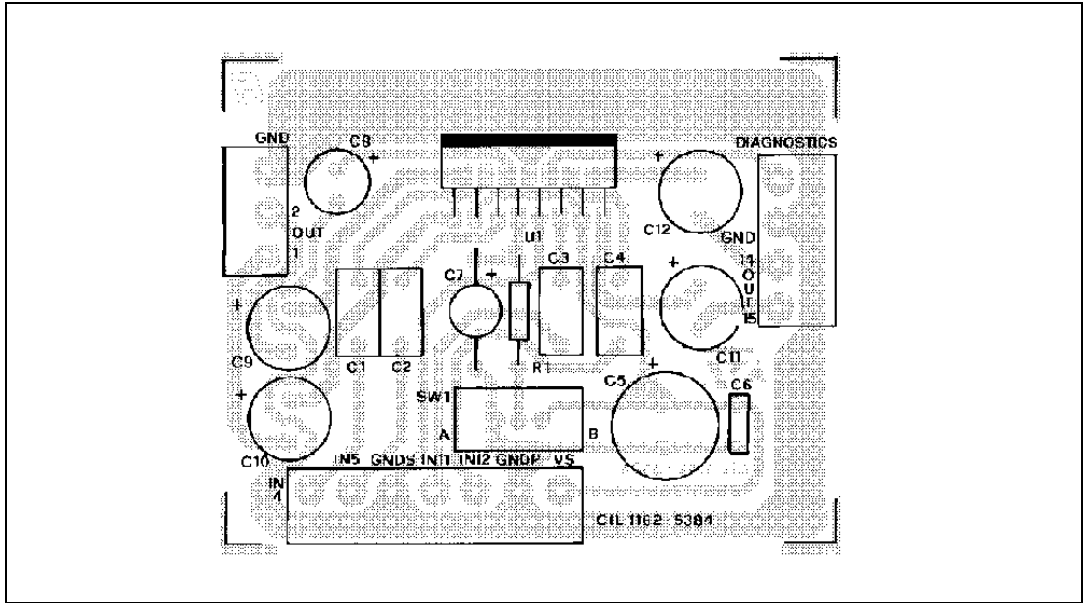
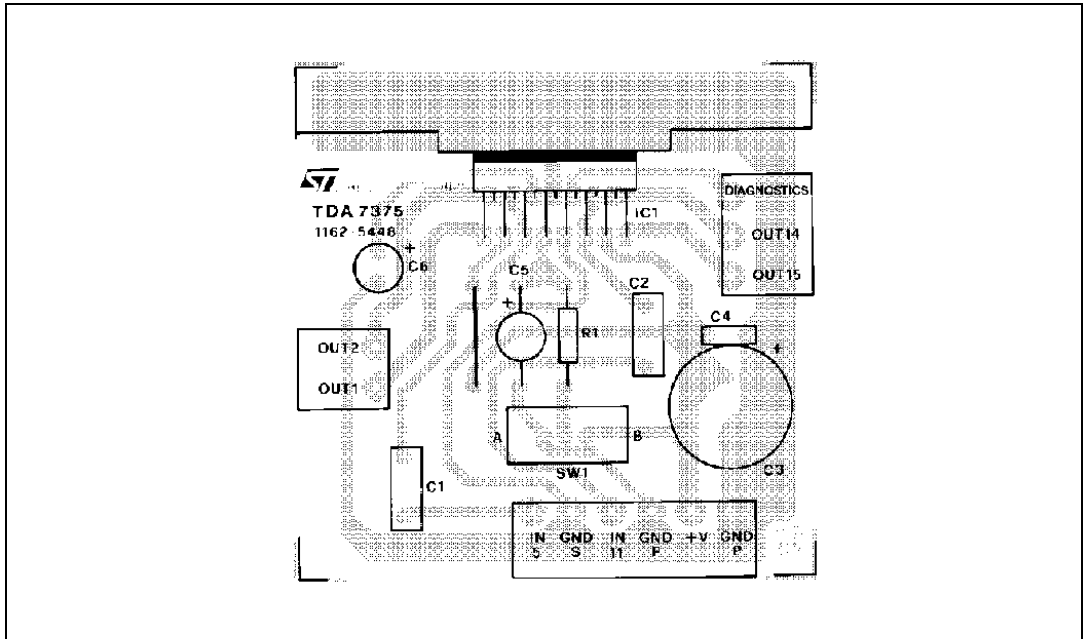

Figure 7. PCB and component layout of the *Figure 4*



3.1 Electrical characteristics curves

Figure 8. Quiescent drain current vs. supply voltage (Single ended and bridge)

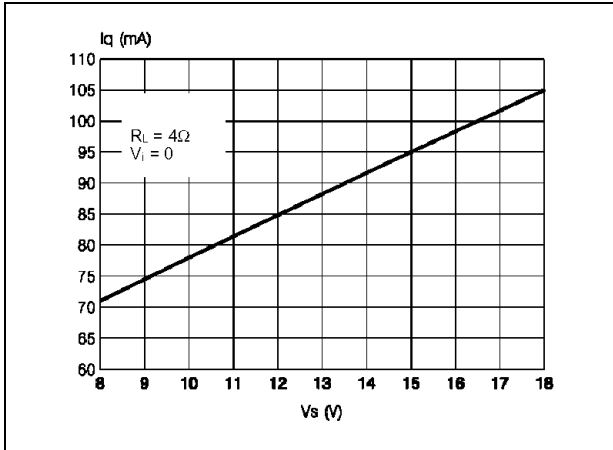

Figure 9. Quiescent output voltage vs. supply voltage (Single ended and bridge)

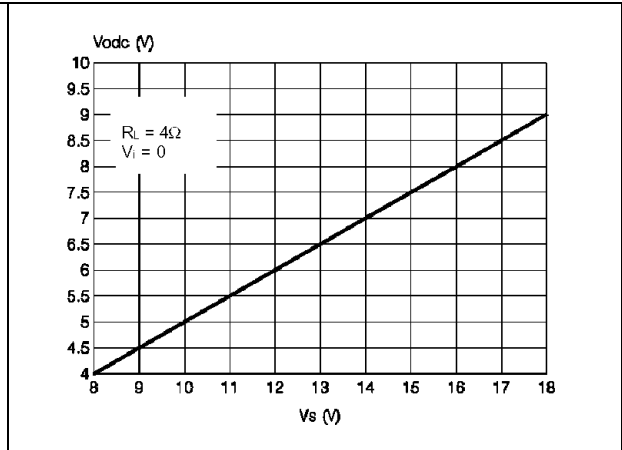

Figure 10. Output power vs. supply voltage (2Ω, S.E.)

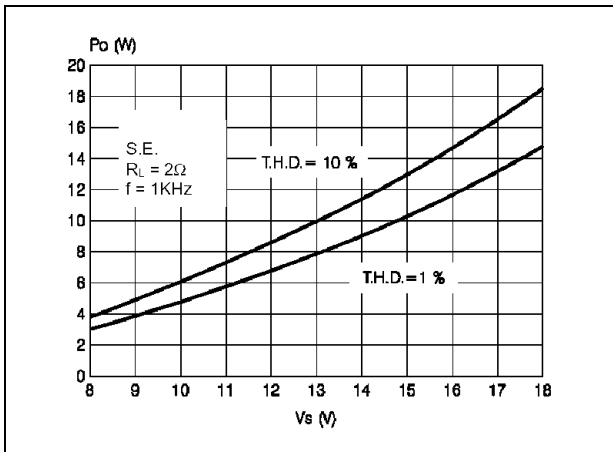

Figure 11. Output power vs. supply voltage (4Ω, S.E.)

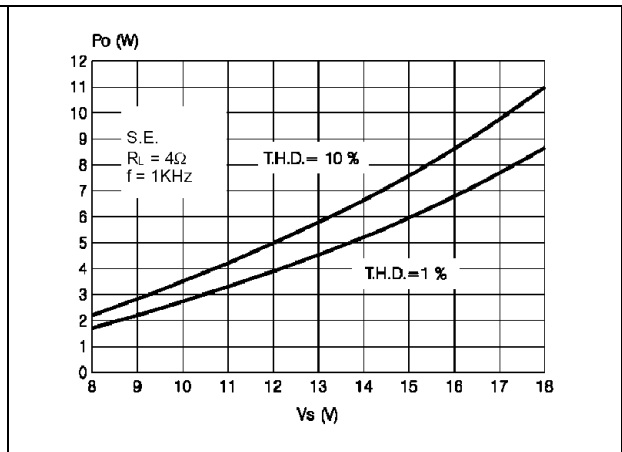

Figure 12. Output power vs. supply voltage (4Ω, BTL)

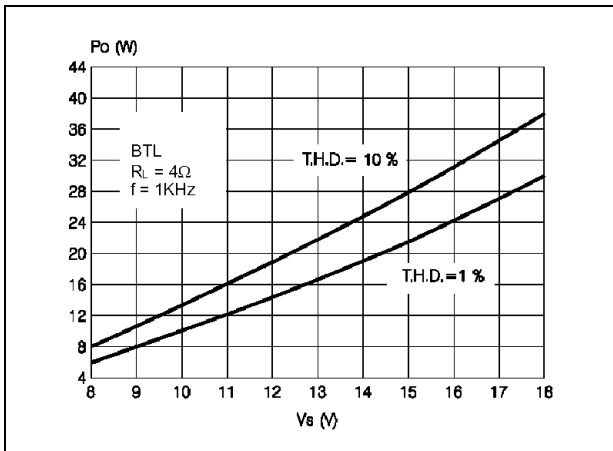

Figure 13. Distortion vs. output power (2Ω, S.E.)

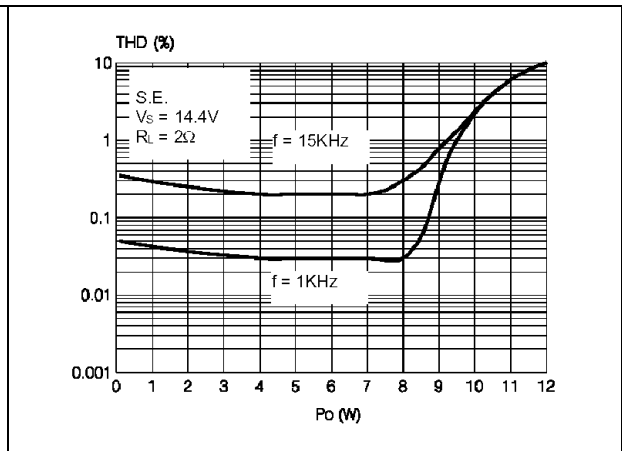

Figure 14. Distortion vs. output power (4Ω, S.E.)

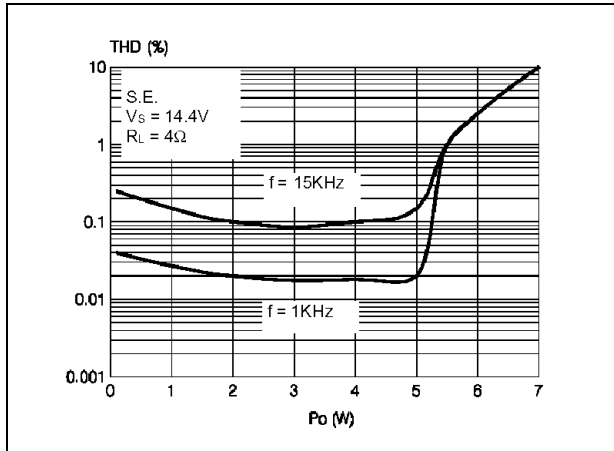

Figure 15. Distortion vs. output power (4Ω, BTL)

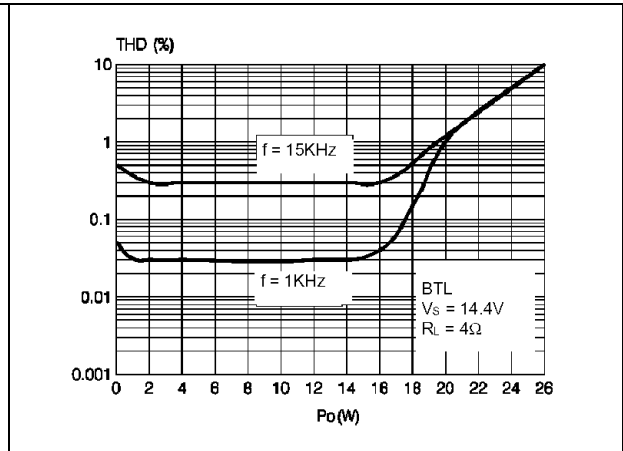

Figure 16. Crosstalk vs. frequency

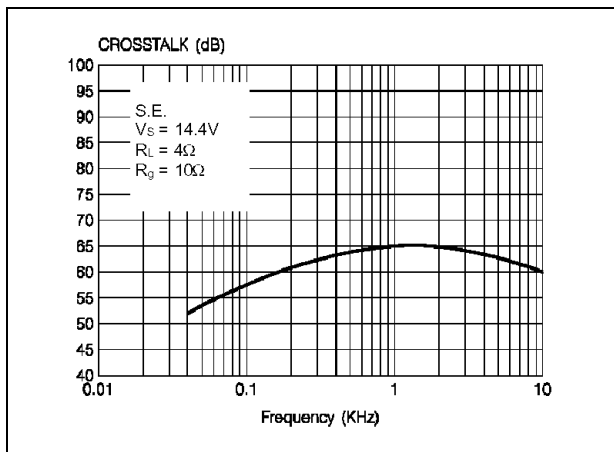

Figure 17. Supply voltage rejection vs. frequency (BTL)

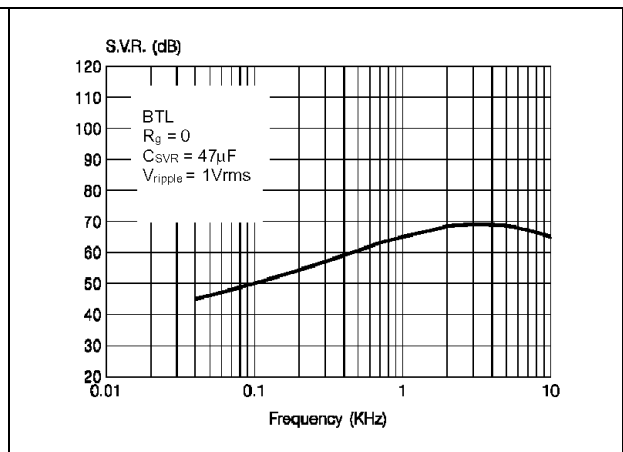

Figure 18. Supply voltage rejection vs. frequency (S.E.)

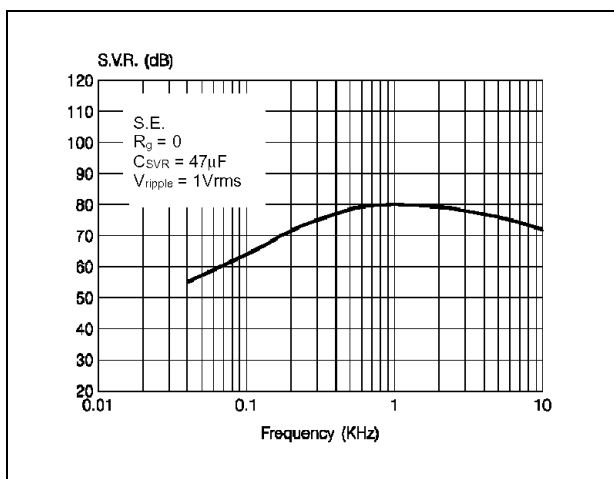

Figure 19. Standby attenuation vs. threshold voltage

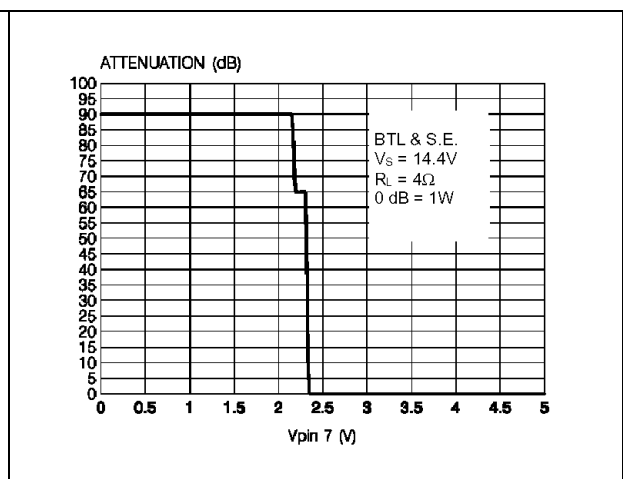

Figure 20. Total power dissipation and efficiency vs. output power (S.E.)

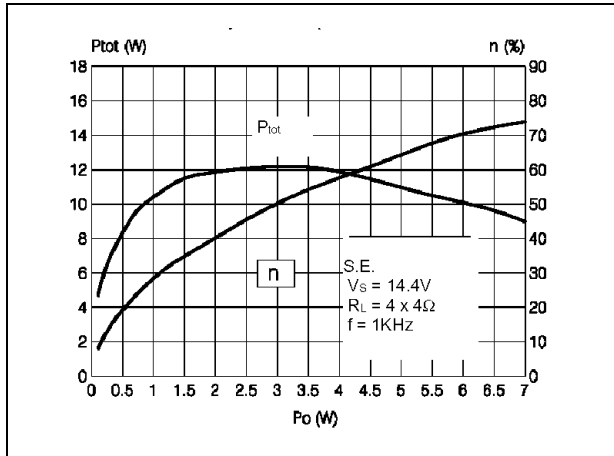
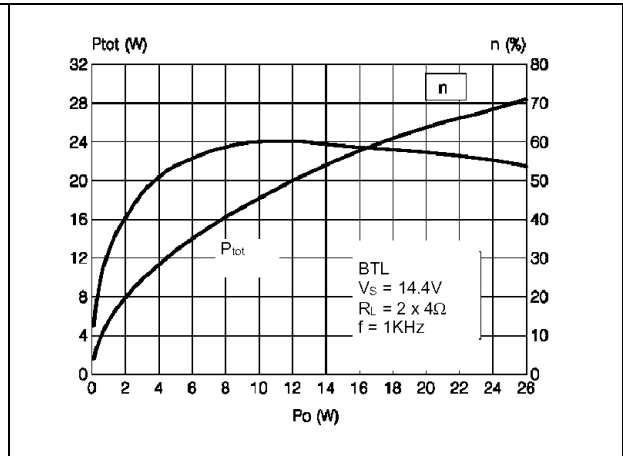

Figure 21. Total power dissipation and efficiency vs. output power (BTL)



4 Functional description

4.1 High application flexibility

The availability of 4 independent channels makes it possible to accomplish several kinds of applications ranging from 4 speakers stereo (F/R) to 2 speakers bridge solutions.

In case of working in single ended conditions the polarity of the speakers driven by the inverting amplifier must be reversed respect to those driven by non inverting channels. This is to avoid phase inconveniences causing sound alterations especially during the reproduction of low frequencies.

4.2 Easy single ended to bridge transition

The change from single ended to bridge configurations is made simply by means of a short circuit across the inputs, that is no need of further external components.

4.3 Gain internally fixed to 20 dB in single ended, 26 dB in bridge

Advantages of this design choice are in terms of:

- components and space saving
- output noise, supply voltage rejection and distortion optimization

4.4 Silent turn on/off and muting/standby function

The standby can be easily activated by means of a CMOS level applied to pin 7 through a RC filter.

Under standby conditions the device is turned off completely (supply current = 1 μ A typ.; output attenuation = 80 dB min.). Every ON/OFF operation is virtually pop free.

Furthermore, at turn-on the device stays in muting conditions for a time determined by the value assigned to the SVR capacitor.

While in muting the device outputs become insensitive to any kind of signal that may be present at the input terminals. In other words every transient coming from previous stages doesn't produce unpleasant acoustic effects to the speakers.

4.5 Output stage

The fully complementary output stage was made possible by the development of a new component: the ST exclusive power ICV PNP.

A novel design based upon the connection shown in [Figure 22](#) has then allowed the full exploitation of its possibilities. The clear advantages that this new approach has over classical output stages are described below.

4.5.1 Rail-to-rail output voltage swing with no need of bootstrap capacitors

The output swing is limited only by the V_{CEsat} of the output transistors, which is in the range of 0.3Ω (R_{sat}) each. Classical solutions adopting composite PNP-NPN for the upper output stage have higher saturation loss on the top side of the waveform.

This unbalanced saturation causes a significant power reduction. The only way to recover power consists of the addition of expensive bootstrap capacitors.

4.5.2 Absolute stability without any external compensation

Referring to the circuit of [Figure 22](#) the gain V_{Out}/V_{In} is greater than unity, approximately $1+R2/R1$. The DC output ($V_{CC}/2$) is fixed by an auxiliary amplifier common to all the channels.

By controlling the amount of this local feedback it is possible to force the loop gain ($A*\beta$) to less than unity at frequency for which the phase shift is 180° . This means that the output buffer is intrinsically stable and not prone to oscillation.

Most remarkably, the above feature has been achieved in spite of the very low closed loop gain of the amplifier. In contrast, with the classical PNP-NPN stage, the solution adopted for reducing the gain at high frequencies makes use of external RC networks, namely the Boucherot cells.

4.6 Built-in short circuit protection

Figure 22. The new output stage

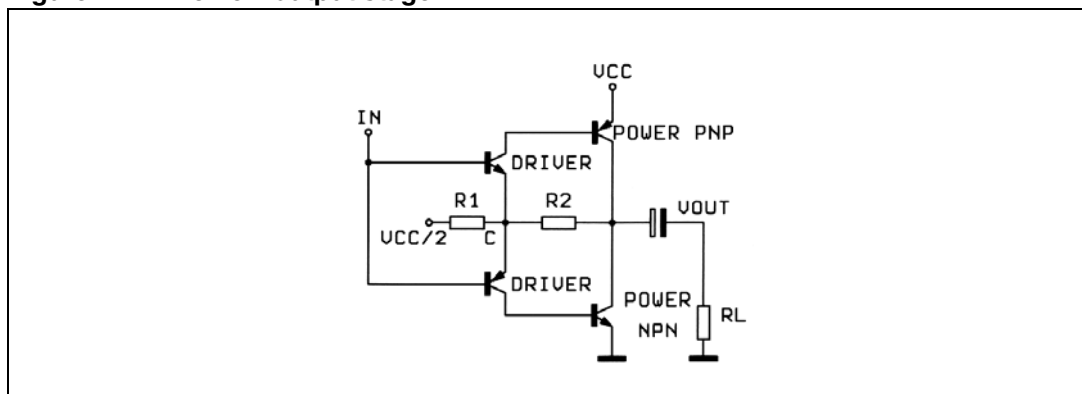

Reliable and safe operation, in presence of all kinds of short circuit involving the outputs is assured by BUILT-IN protectors. Additionally to the AC/DC short circuit to GND, to V_S , across the speaker, a SOFT SHORT condition is signalled out during the TURN-ON PHASE so assuring correct operation for the device itself and for the loudspeaker.

This particular kind of protection acts in a way to avoid that the device is turned on (by Standby) when a resistive path (less than 16 ohms) is present between the output and GND. As the involved circuitry is normally disabled when a current higher than 5 mA is flowing into the ST-BY pin, it is important, in order not to disable it, to have the external current source driving the ST-BY pin limited to 5 mA.

This extra function becomes particularly attractive when, in the single ended configuration, one capacitor is shared between two outputs (see [Figure 23](#)). Supposing that the output

capacitor C_{out} for any reason is shorted, the loudspeaker will not be damaged being this soft short circuit condition revealed.

Figure 23. Single ended configuration

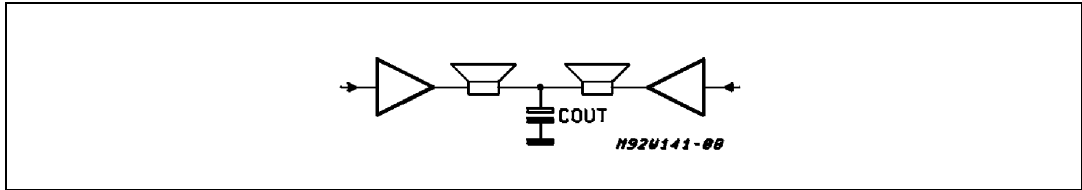

4.6.1 Diagnostics facility

The TDA7375AV is equipped with a diagnostic circuitry able to detect the following events:

- Clipping in the output signal
- Thermal shutdown
- Output fault
 - short to GND
 - short to V_S
 - soft short at turn on

The information is available across an open collector output (pin 10) through a current sinking when the event is detected. A current sinking at pin 10 is triggered when a certain distortion level is reached at any of the outputs. This function allows gain compression possibility whenever the amplifier is over driven.

4.6.2 Thermal shutdown

In this case the output 10 will signal the proximity of the junction temperature to the shutdown threshold. Typically current sinking at pin 10 will start $\sim 10^\circ\text{C}$ before the shutdown threshold is reached.

Figure 24. Clipping detection waveforms

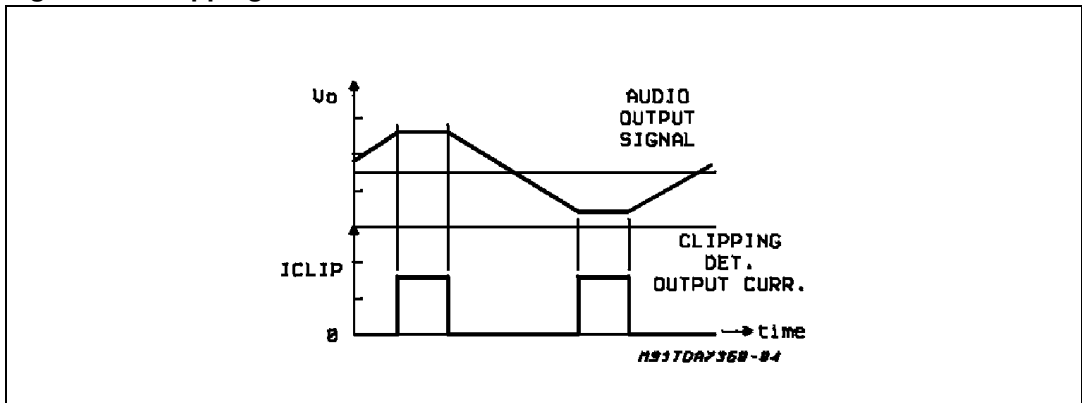

Figure 25. Output fault waveforms (see Figure 26)

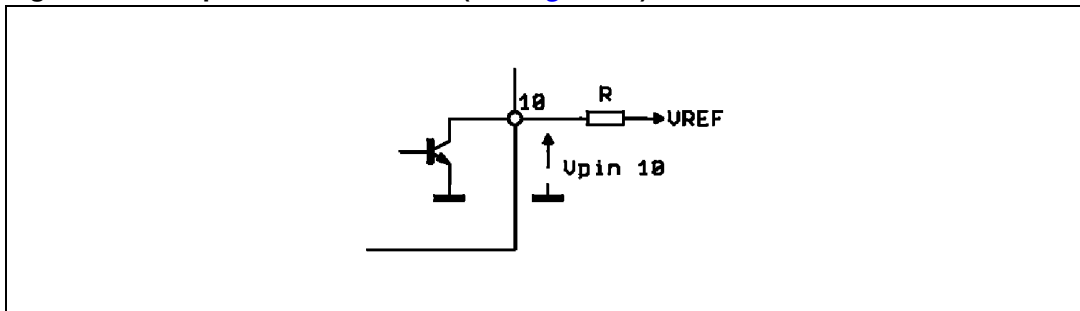
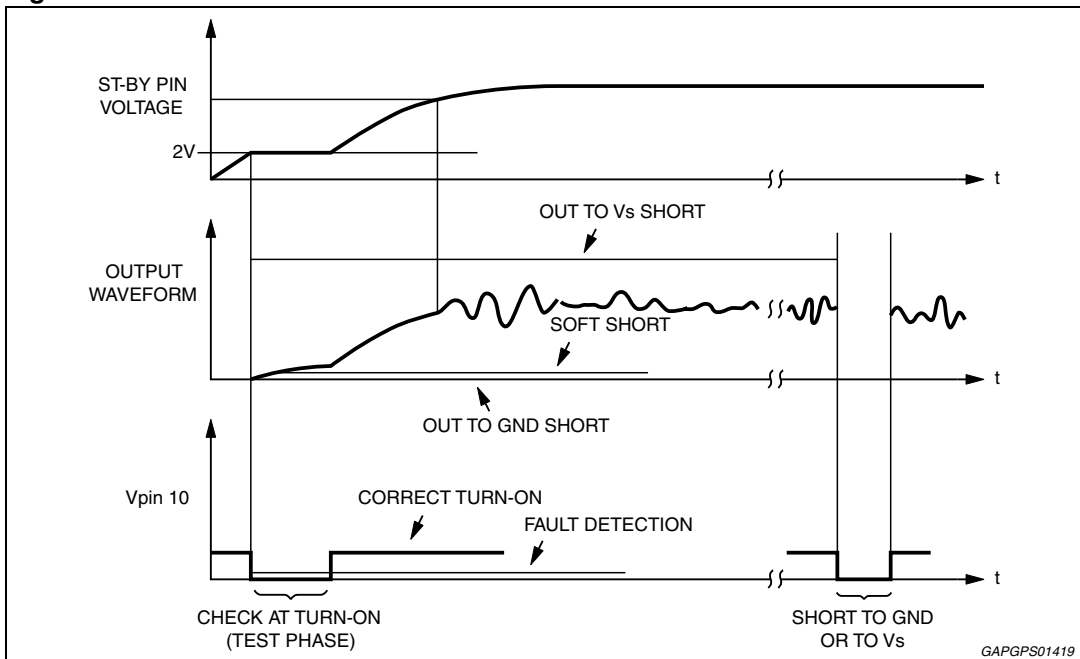

Figure 26. Fault waveforms



4.7 Handling of the diagnostics information

As various kinds of information are available at the same pin (clipping detection, output fault, thermal proximity), this signal must be handled properly in order to discriminate each event.

This could be done by taking into account the different timing of the diagnostic output during each case.

Normally the clip detector signalling produces a low level at pin 10 that is shorter referred to every kind of fault detection; based on this assumption an interface circuitry to differentiate the information is represented in the following schematic.

Figure 27. Waveforms

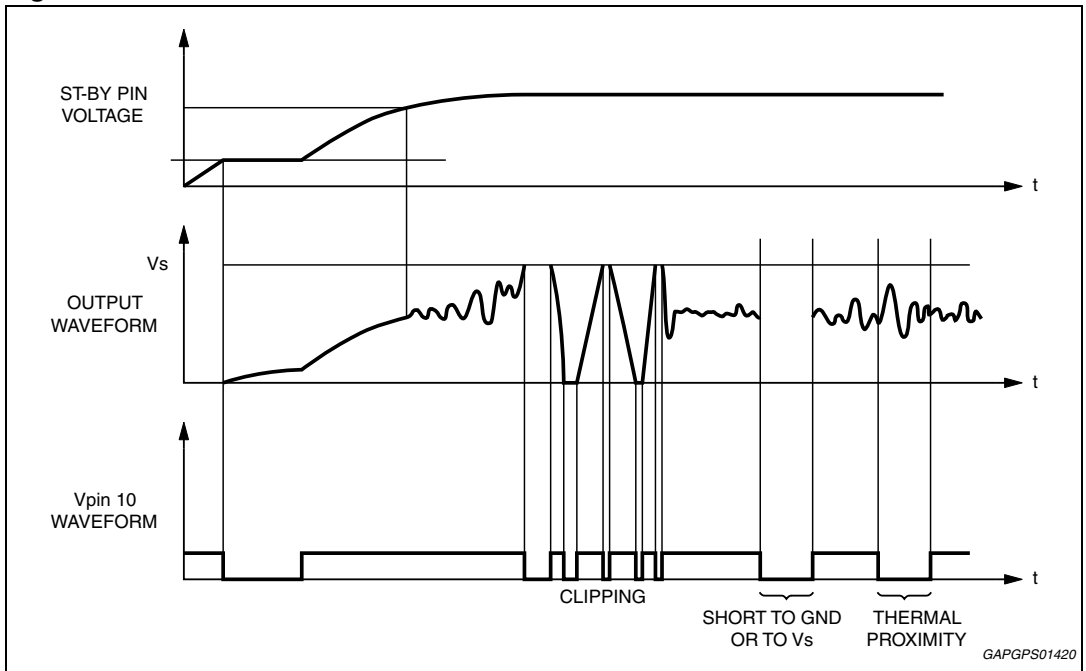
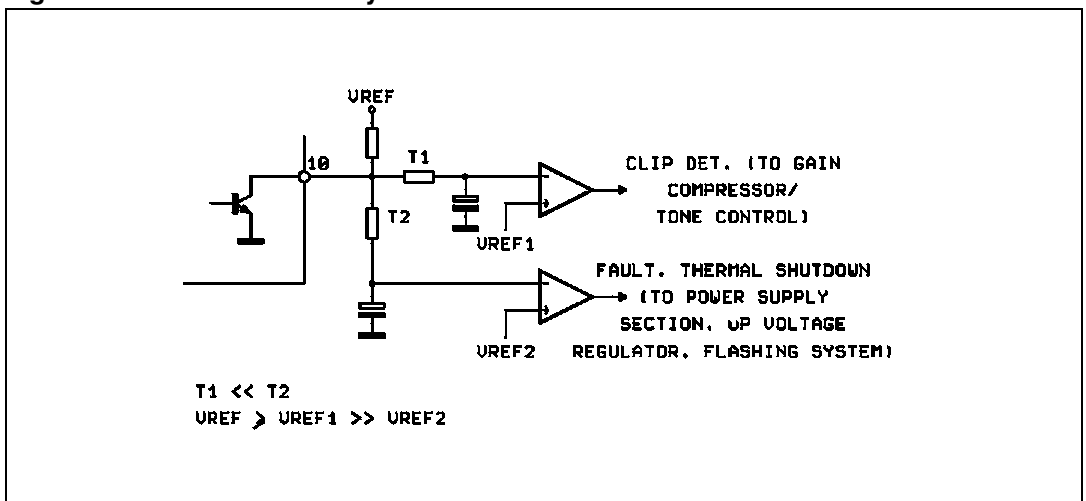

Figure 28. Interface circuitry to differentiate the information schematic



5 Package information

In order to meet environmental requirements, ST offers these devices in different grades of ECOPACK® packages, depending on their level of environmental compliance. ECOPACK® specifications, grade definitions and product status are available at: www.st.com.

ECOPACK® is an ST trademark.

Figure 29. Multiwatt 15 mechanical data and package dimensions

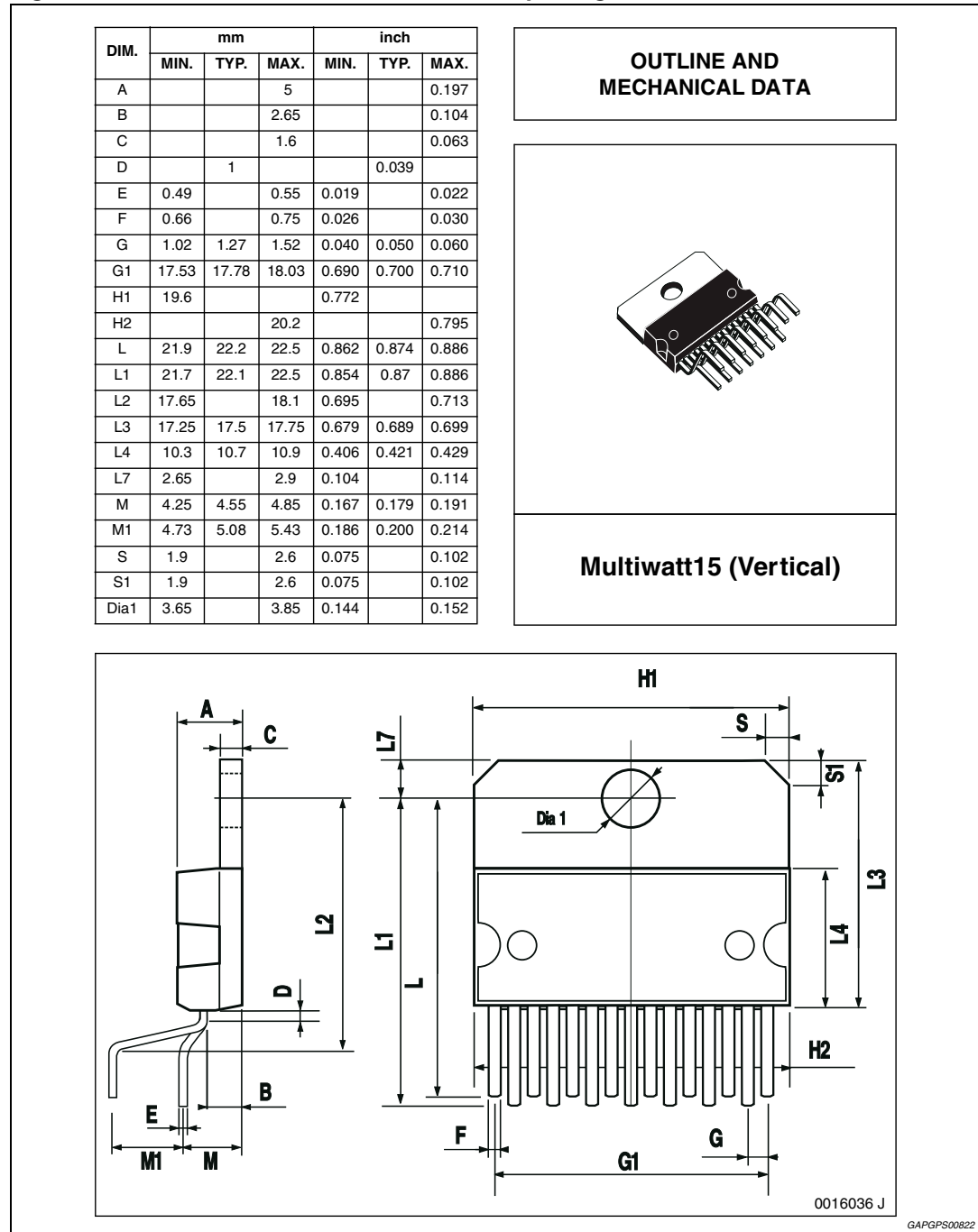

6 Revision history

Table 5. Document revision history

Date	Revision	Changes
15-Mar-2005	1	Initial release.
24-Jul-2008	2	Removed the package Multiwatt 15 horizontal.
05-Dec-2008	3	Document reformatted. Updated Section 5: Package information .
13-Feb-2012	4	Updated Table 1: Device summary on page 1 .
16-Sep-2013	5	Updated Disclaimer.

Please Read Carefully:

Information in this document is provided solely in connection with ST products. STMicroelectronics NV and its subsidiaries ("ST") reserve the right to make changes, corrections, modifications or improvements, to this document, and the products and services described herein at any time, without notice.

All ST products are sold pursuant to ST's terms and conditions of sale.

Purchasers are solely responsible for the choice, selection and use of the ST products and services described herein, and ST assumes no liability whatsoever relating to the choice, selection or use of the ST products and services described herein.

No license, express or implied, by estoppel or otherwise, to any intellectual property rights is granted under this document. If any part of this document refers to any third party products or services it shall not be deemed a license grant by ST for the use of such third party products or services, or any intellectual property contained therein or considered as a warranty covering the use in any manner whatsoever of such third party products or services or any intellectual property contained therein.

UNLESS OTHERWISE SET FORTH IN ST'S TERMS AND CONDITIONS OF SALE ST DISCLAIMS ANY EXPRESS OR IMPLIED WARRANTY WITH RESPECT TO THE USE AND/OR SALE OF ST PRODUCTS INCLUDING WITHOUT LIMITATION IMPLIED WARRANTIES OF MERCHANTABILITY, FITNESS FOR A PARTICULAR PURPOSE (AND THEIR EQUIVALENTS UNDER THE LAWS OF ANY JURISDICTION), OR INFRINGEMENT OF ANY PATENT, COPYRIGHT OR OTHER INTELLECTUAL PROPERTY RIGHT.

ST PRODUCTS ARE NOT DESIGNED OR AUTHORIZED FOR USE IN: (A) SAFETY CRITICAL APPLICATIONS SUCH AS LIFE SUPPORTING, ACTIVE IMPLANTED DEVICES OR SYSTEMS WITH PRODUCT FUNCTIONAL SAFETY REQUIREMENTS; (B) AERONAUTIC APPLICATIONS; (C) AUTOMOTIVE APPLICATIONS OR ENVIRONMENTS, AND/OR (D) AEROSPACE APPLICATIONS OR ENVIRONMENTS. WHERE ST PRODUCTS ARE NOT DESIGNED FOR SUCH USE, THE PURCHASER SHALL USE PRODUCTS AT PURCHASER'S SOLE RISK, EVEN IF ST HAS BEEN INFORMED IN WRITING OF SUCH USAGE, UNLESS A PRODUCT IS EXPRESSLY DESIGNATED BY ST AS BEING INTENDED FOR "AUTOMOTIVE, AUTOMOTIVE SAFETY OR MEDICAL" INDUSTRY DOMAINS ACCORDING TO ST PRODUCT DESIGN SPECIFICATIONS. PRODUCTS FORMALLY ESCC, QML OR JAN QUALIFIED ARE DEEMED SUITABLE FOR USE IN AEROSPACE BY THE CORRESPONDING GOVERNMENTAL AGENCY.

Resale of ST products with provisions different from the statements and/or technical features set forth in this document shall immediately void any warranty granted by ST for the ST product or service described herein and shall not create or extend in any manner whatsoever, any liability of ST.

ST and the ST logo are trademarks or registered trademarks of ST in various countries.

Information in this document supersedes and replaces all information previously supplied.

The ST logo is a registered trademark of STMicroelectronics. All other names are the property of their respective owners.

© 2013 STMicroelectronics - All rights reserved

STMicroelectronics group of companies

Australia - Belgium - Brazil - Canada - China - Czech Republic - Finland - France - Germany - Hong Kong - India - Israel - Italy - Japan - Malaysia - Malta - Morocco - Philippines - Singapore - Spain - Sweden - Switzerland - United Kingdom - United States of America

www.st.com